

**IRON AGE AND ROMAN LANDSCAPES IN THE EAST
MIDLANDS: A CASE STUDY IN INTEGRATED SURVEY**

Jeremy Taylor

(Two volumes)

Volume 2

The copyright of this thesis rests with the author.
No quotation from it should be published without
his prior written consent and information derived
from it should be acknowledged.

Thesis submitted for the degree of Doctor of Philosophy

Department of Archaeology

University of Durham

1996

10 MAR 1997

VOLUME II CONTENTS

CONTENTS OF VOLUME II	xv
FIGURES	282
APPENDIX 1: GAZETTEER OF EXCAVATED AND SURVEYED SITES	447
APPENDIX 2: THE CLASSIFICATION AND RECORDING OF THE FIELDWALKED POTTERY	455
APPENDIX 3: CALIBRATED C-14 DATES FROM THE REGION	458
APPENDIX 4: THE QUANTIFIED POTTERY DATA	475
ACKNOWLEDGEMENTS	

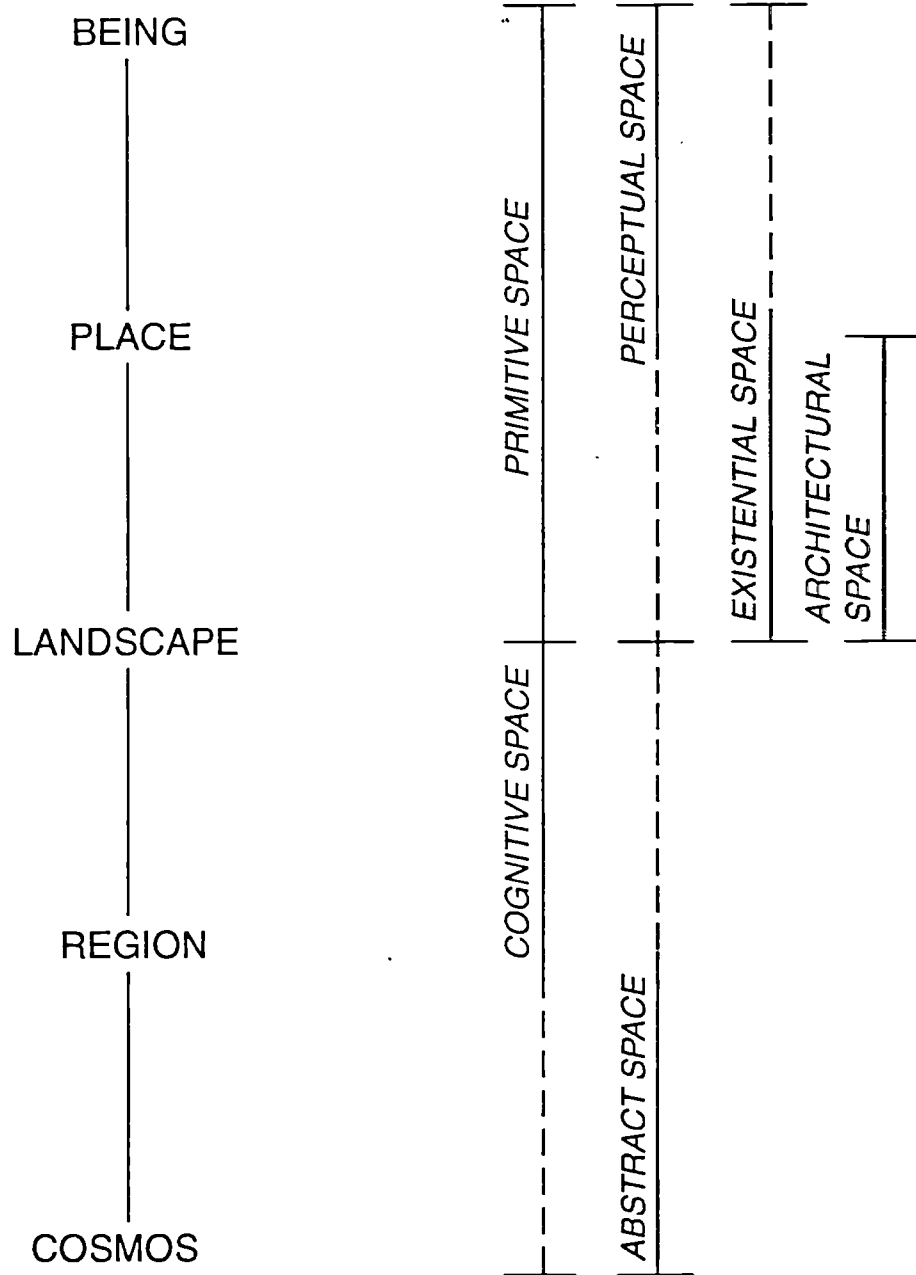

Figure 1.1 A hypothetical model of the structure of space

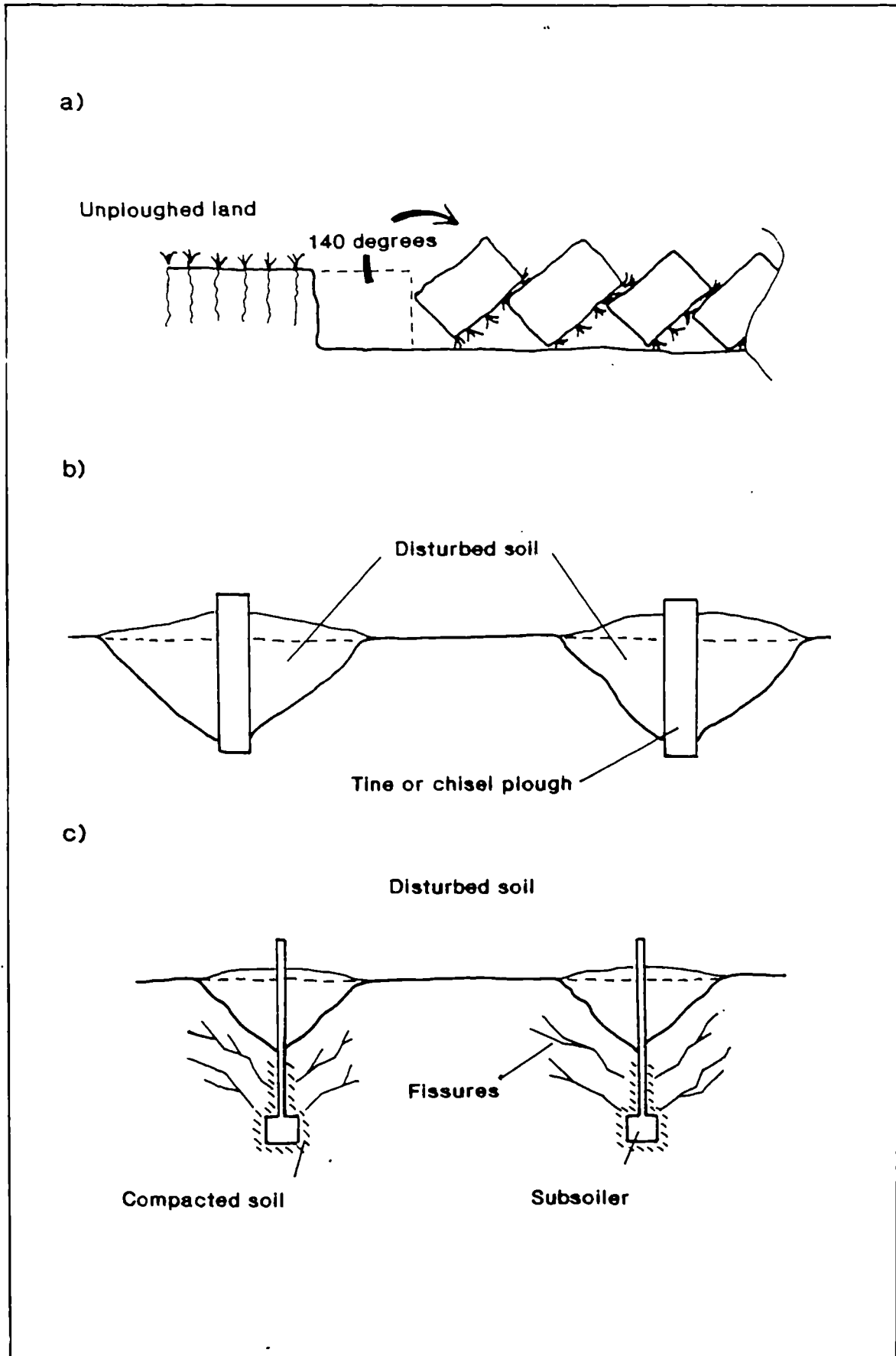

Figure 2.1 The action of a) mouldboard ploughs (from Nicholson 1980, fig. 3), b) tine and chisel ploughs (Spoor 1980, fig. 5), and c) subsoilers on the soil (Spoor 1980, fig. 6).

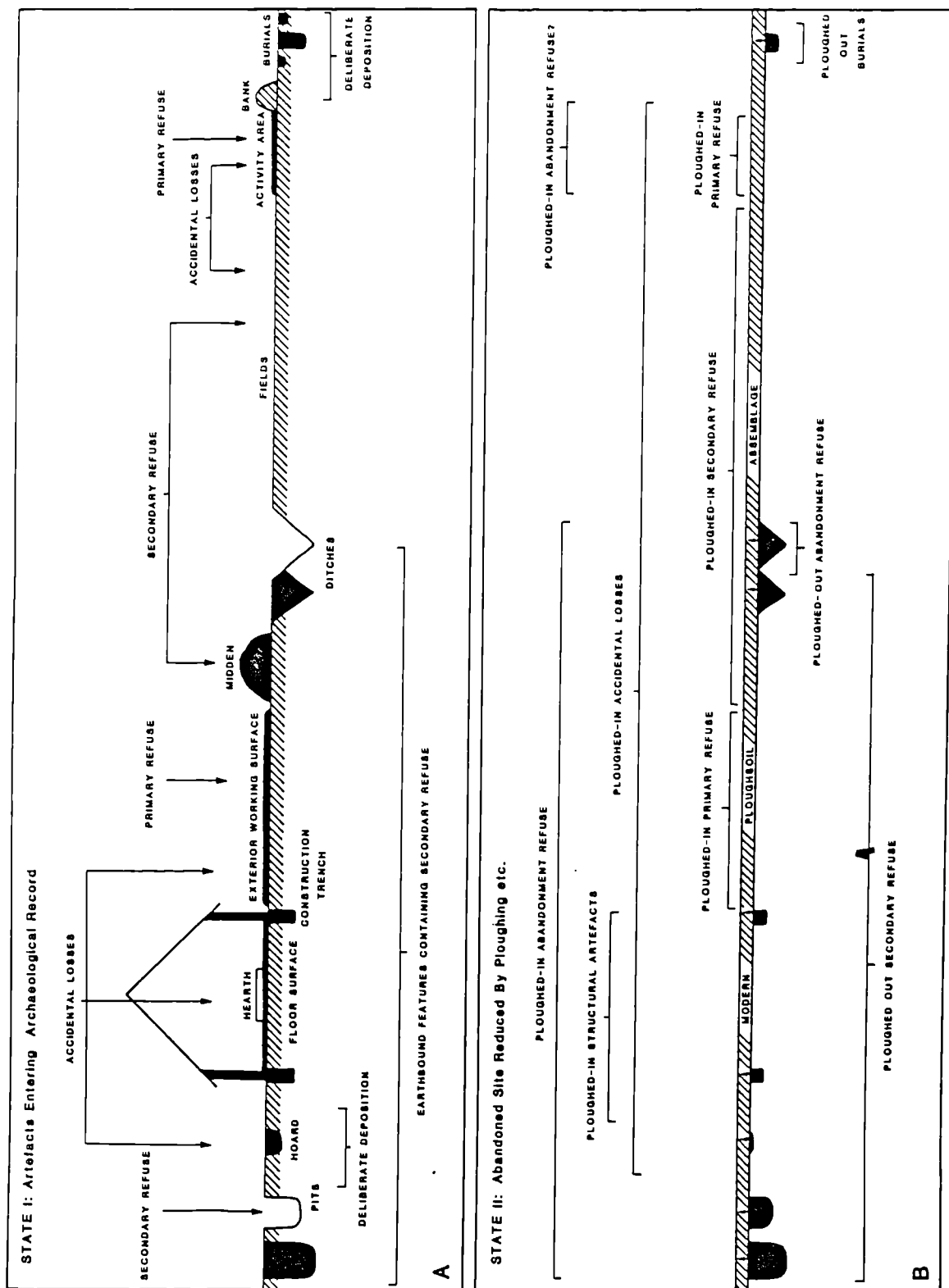

Figure 2.2 The derivation of a ploughsoil assemblage *B* from a hypothetical settlement site *A* (after Haselgrove 1985, fig. 1.3).

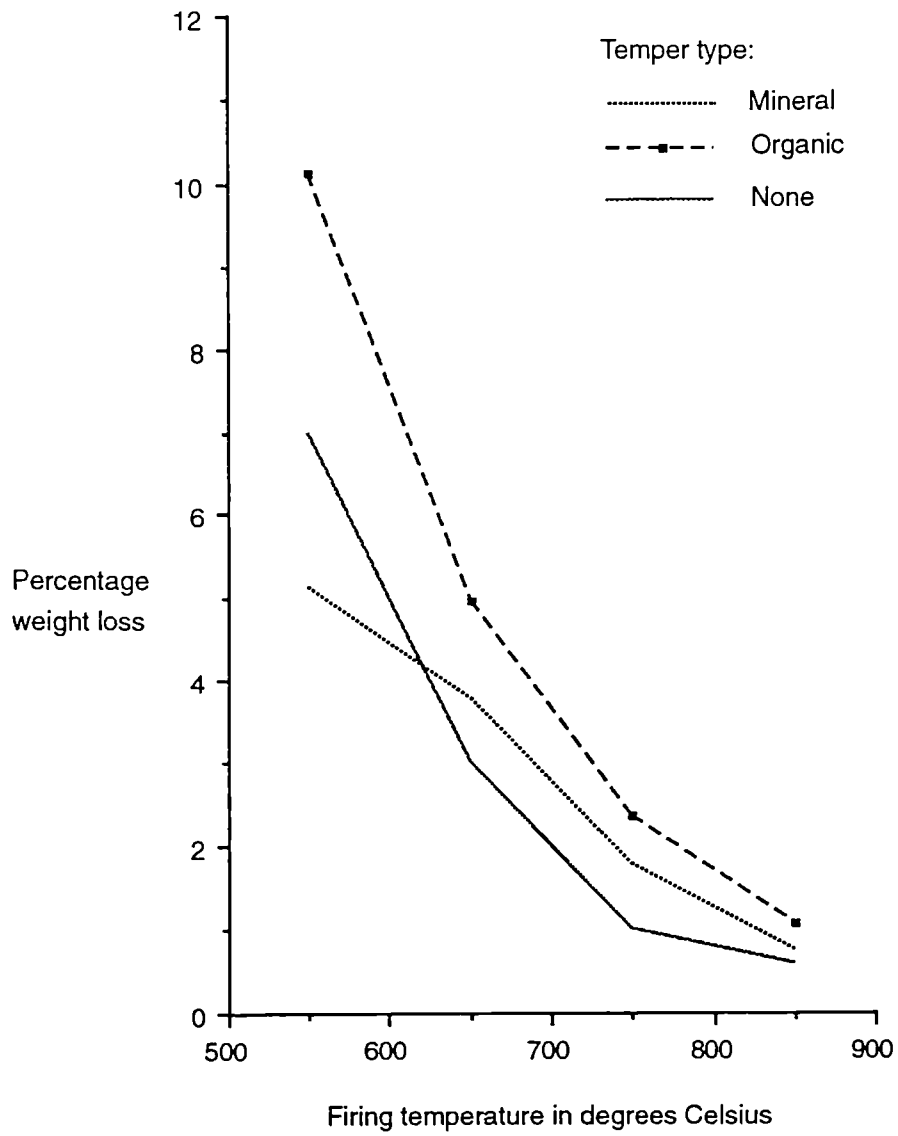

Figure 2.3 The effect of temper type and firing temperature on abrasion resistance (after Skibo *et al.* 1989).

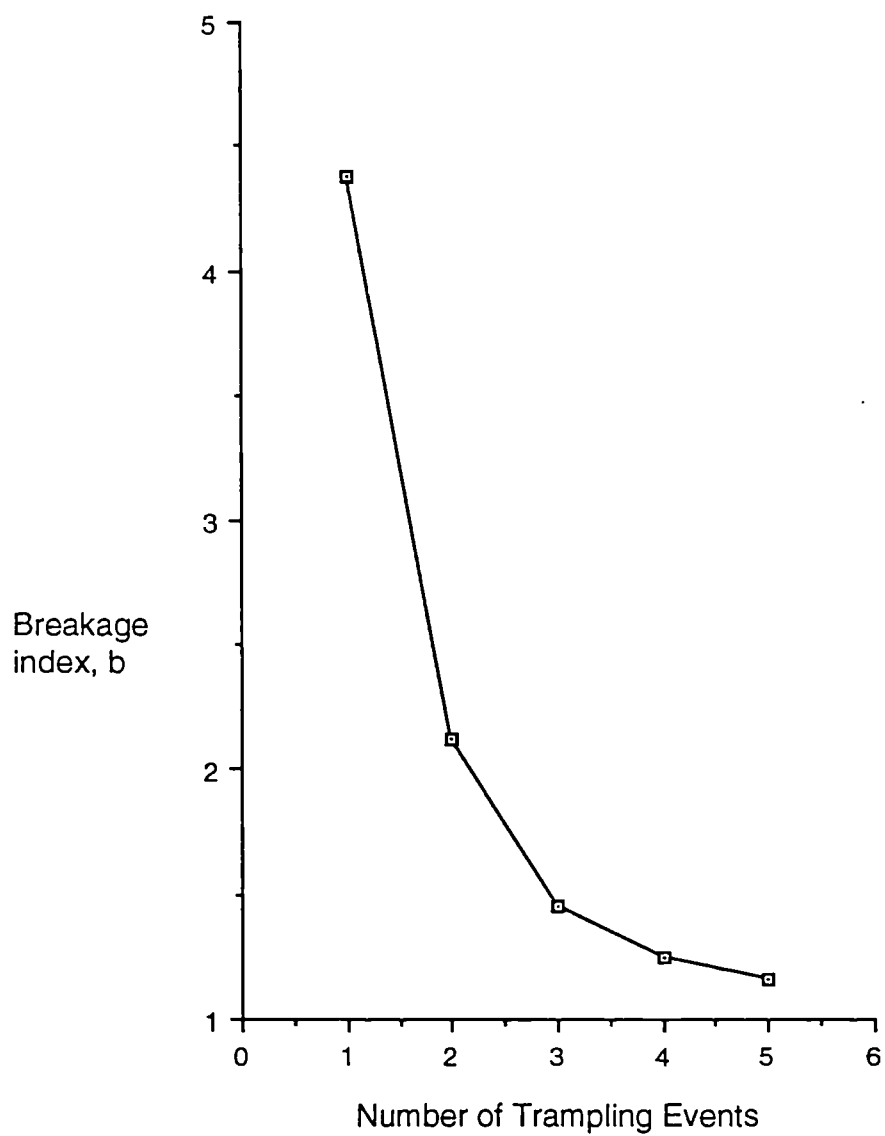

Figure 2.4 Graph of the breakage rate of a group of trampled pottery through time (data from Kirkby & Kirkby 1976, table 3). $B = 1$ is the point at which further breakage ceases.

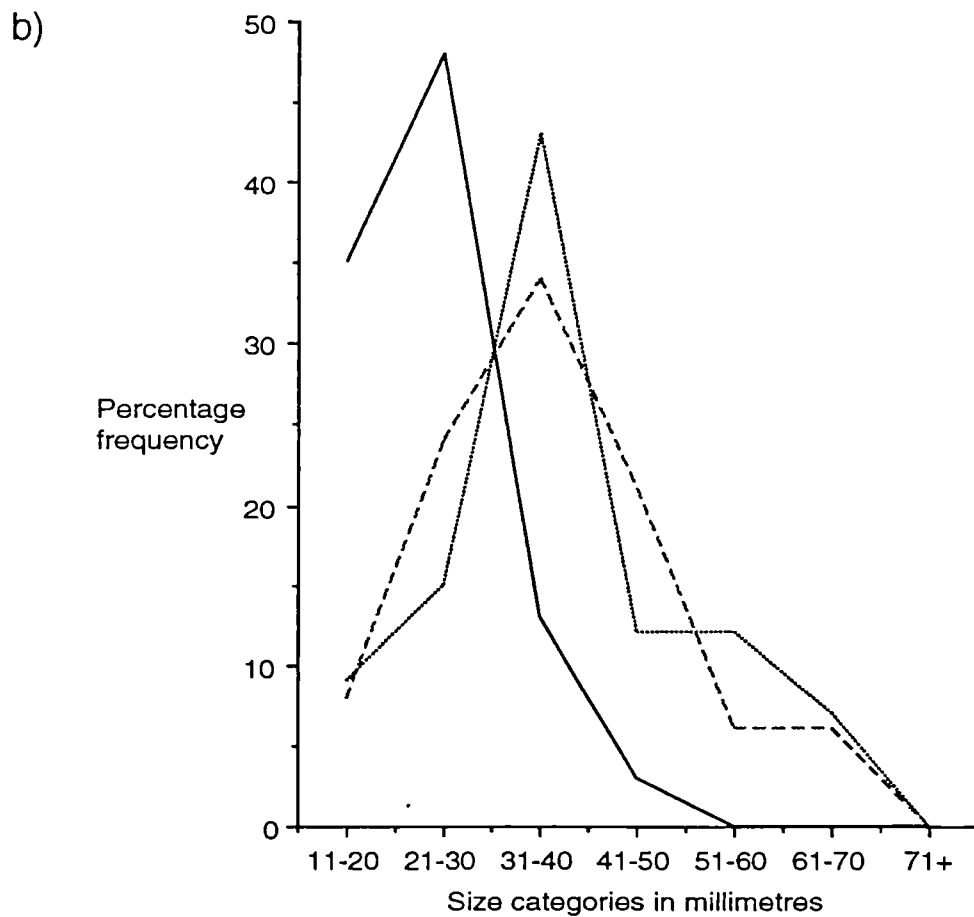
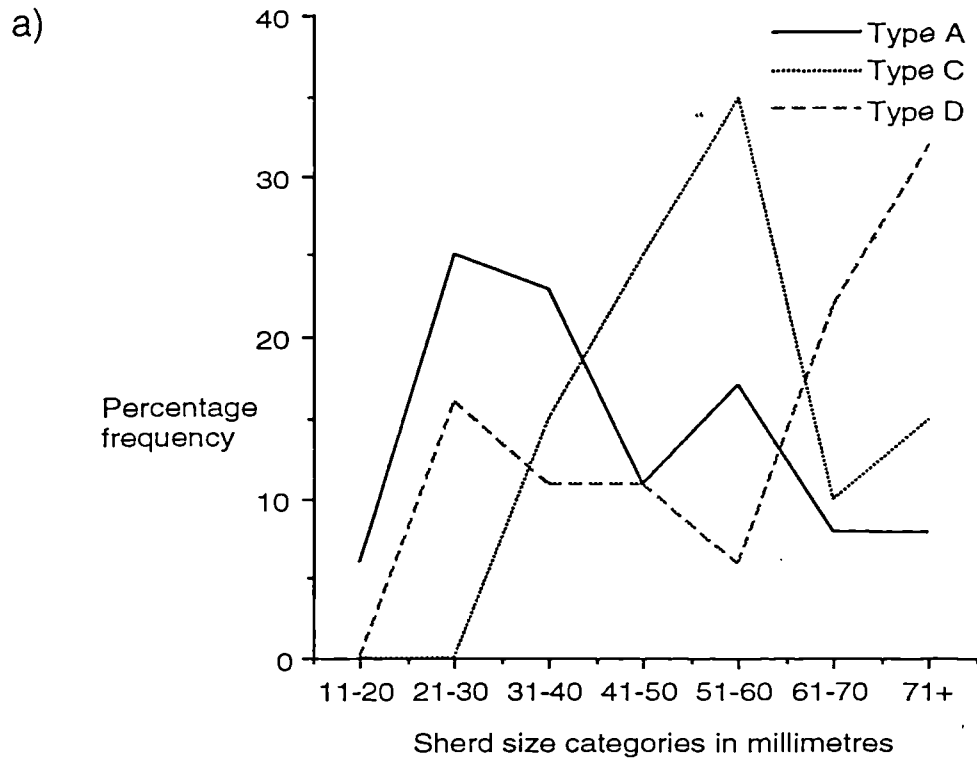

Figure 2.5 The percentage frequency distributions of three pottery assemblages of fabrics A (organic temper), C (sand temper), and D (no temper) a) before trampling and b) after trampling (data from Nielsen 1991).

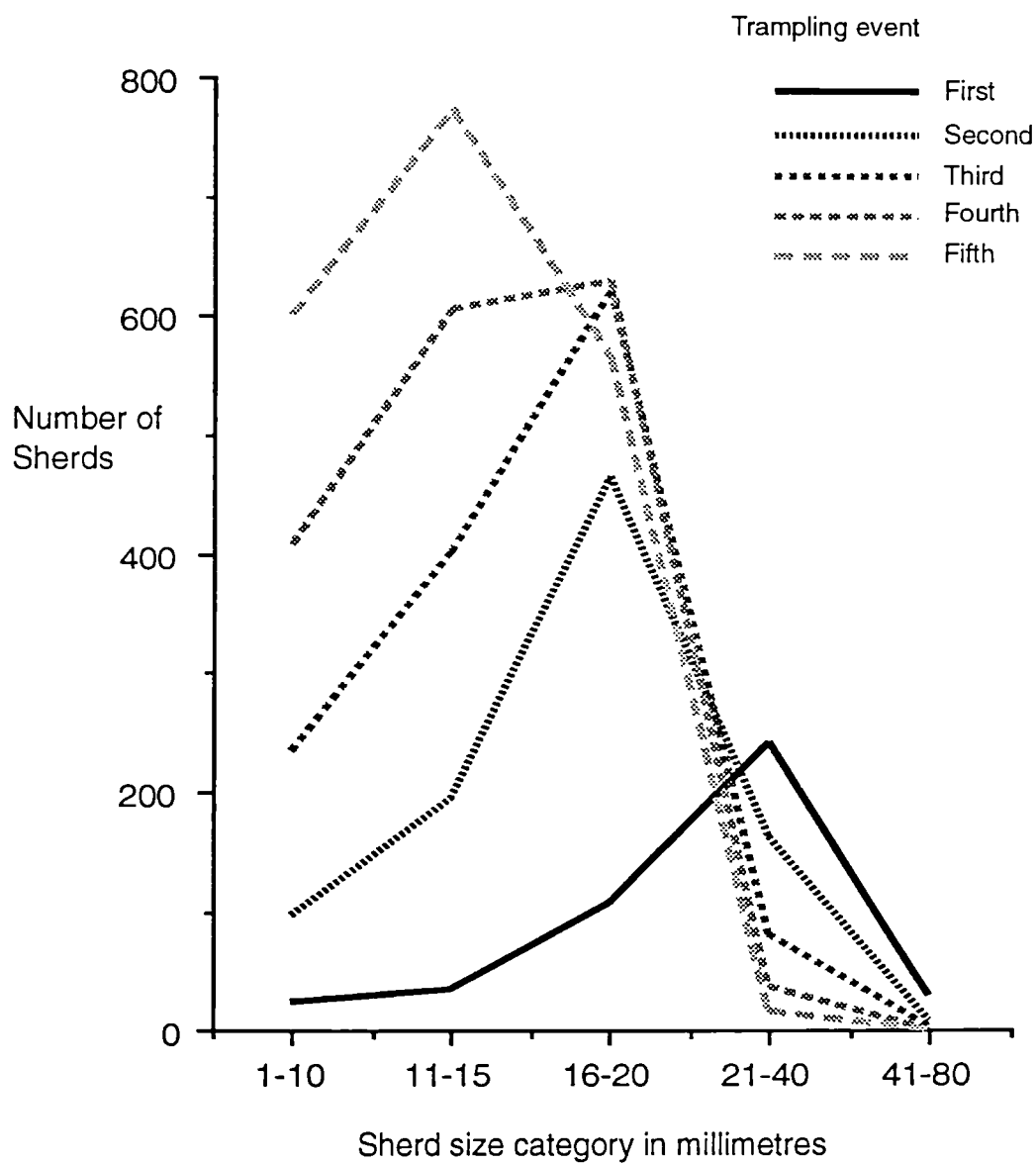

Figure 2.6 The frequency distribution by size category of a single group of sherds after five successive trampling events (data from Kirkby & Kirkby 1976, table 3).

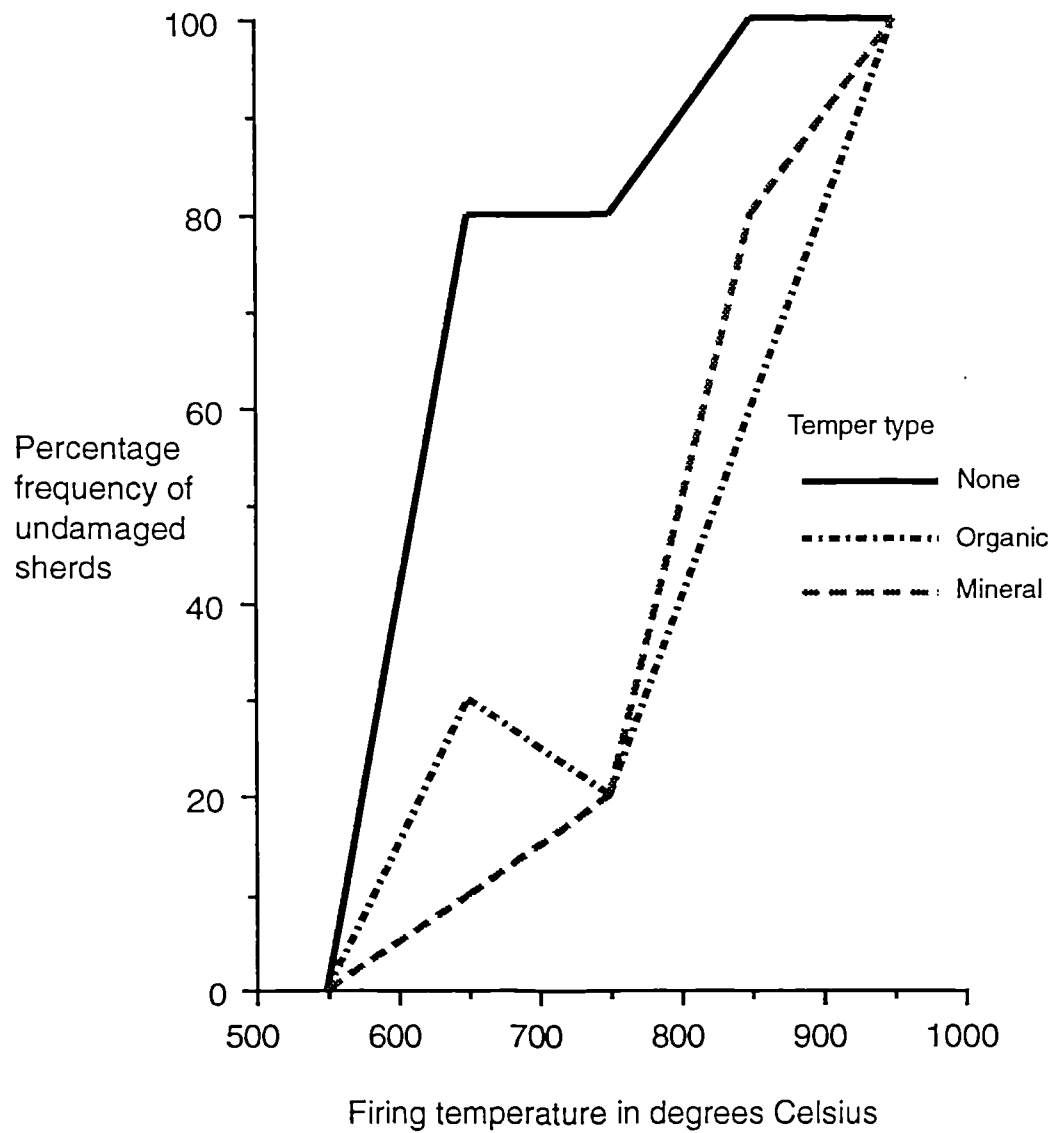

Figure 2.7 The changing frost resistance of different tempered ceramics with increased firing temperature (data from Skibo *et al.* 1991).

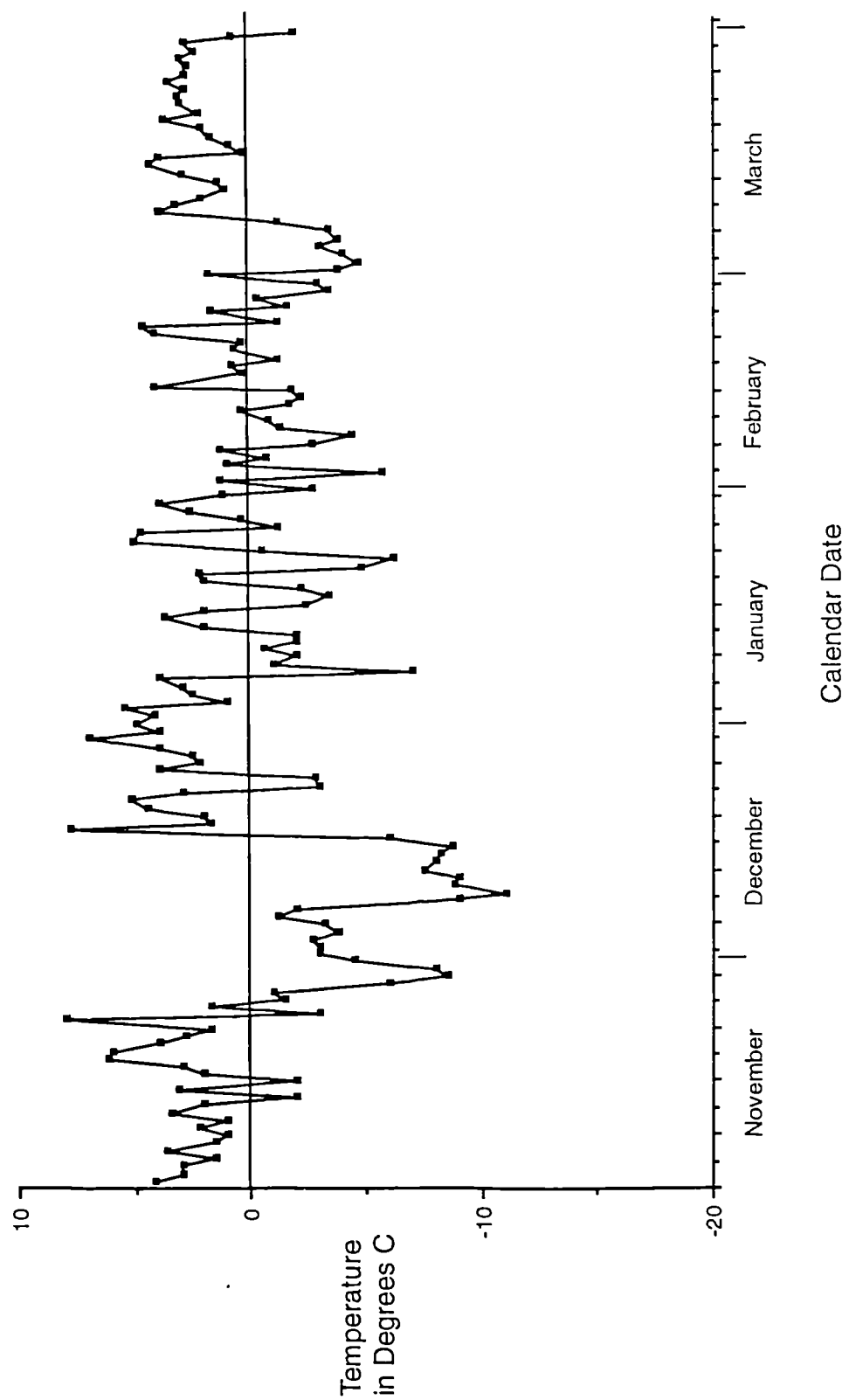

Figure 2.8 Surface minimum temperatures at Butser Hill, Station 1, 1st November^b 1987 to 31st^a March 1988 (data from Reynolds 1988).

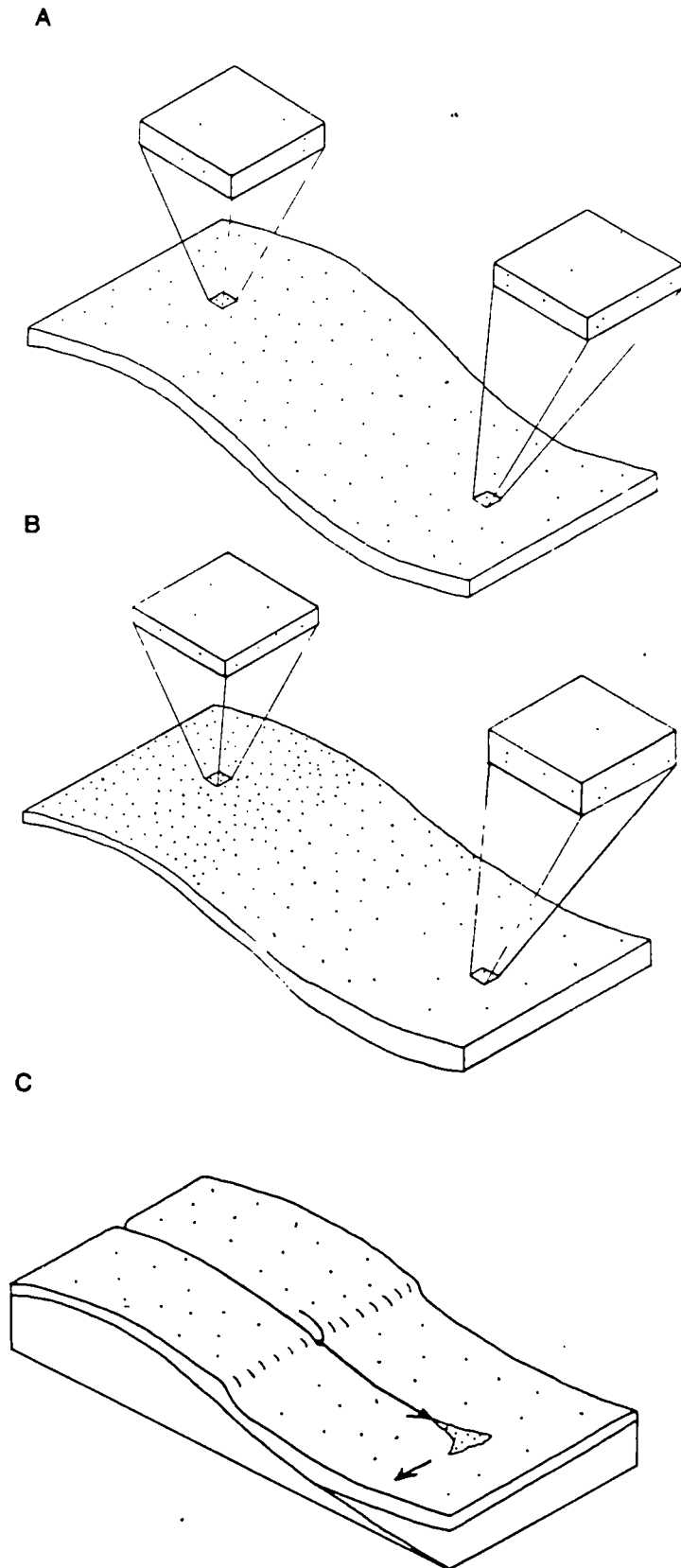

Figure 2.9 Schematic diagram showing the variable effects of soil erosion on the surface densities of artefacts from an area with an even initial distribution a), after common low density erosion b), and rare high level erosion along rills or gullies c).

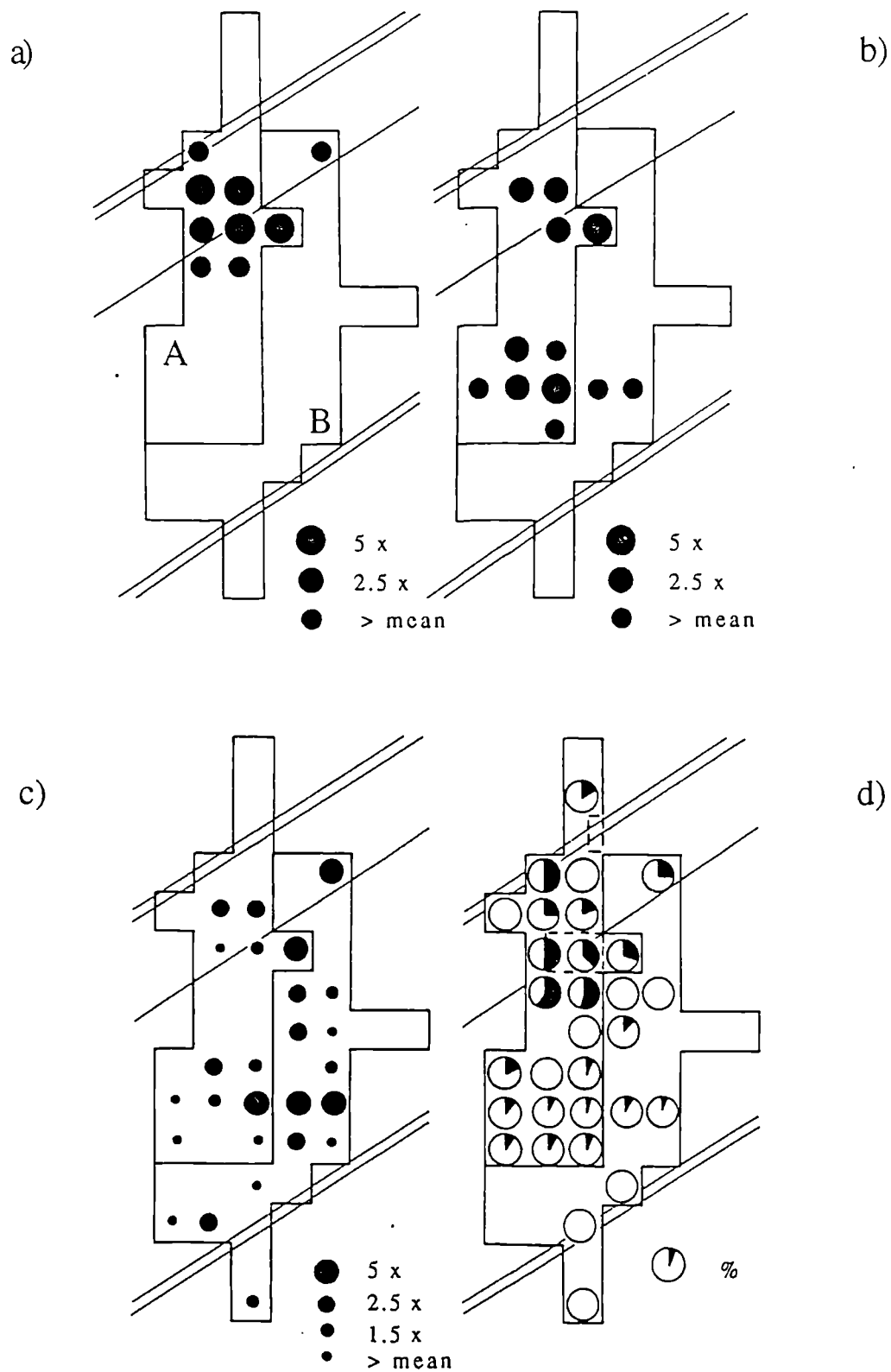

Figure 2.10 Surface collection results at BLG by sherd count. a) iron age pottery, b) Roman pottery, c) Roman pottery adjusted to separate means for zones A and B, and d) proportion of iron age pottery per 20 metre square. Zone A was walked by the experienced team, B by the inexperienced (after Haselgrove 1985, figs. 1.5 & 1.6).

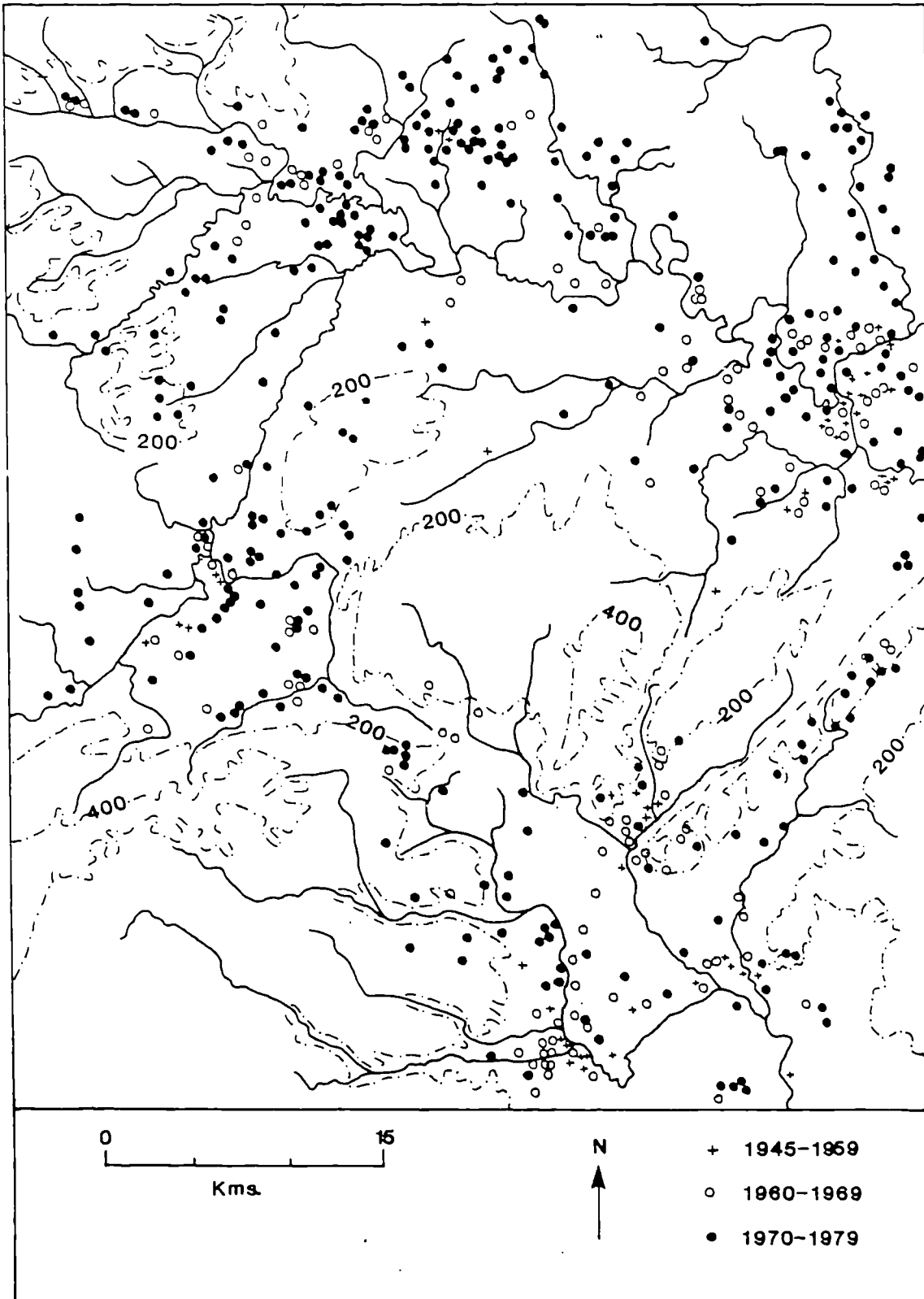

Figure 3.1 Map of the Welsh Marches (from Whimster 1989, fig. 5) showing the distribution of crop mark discovery over time.

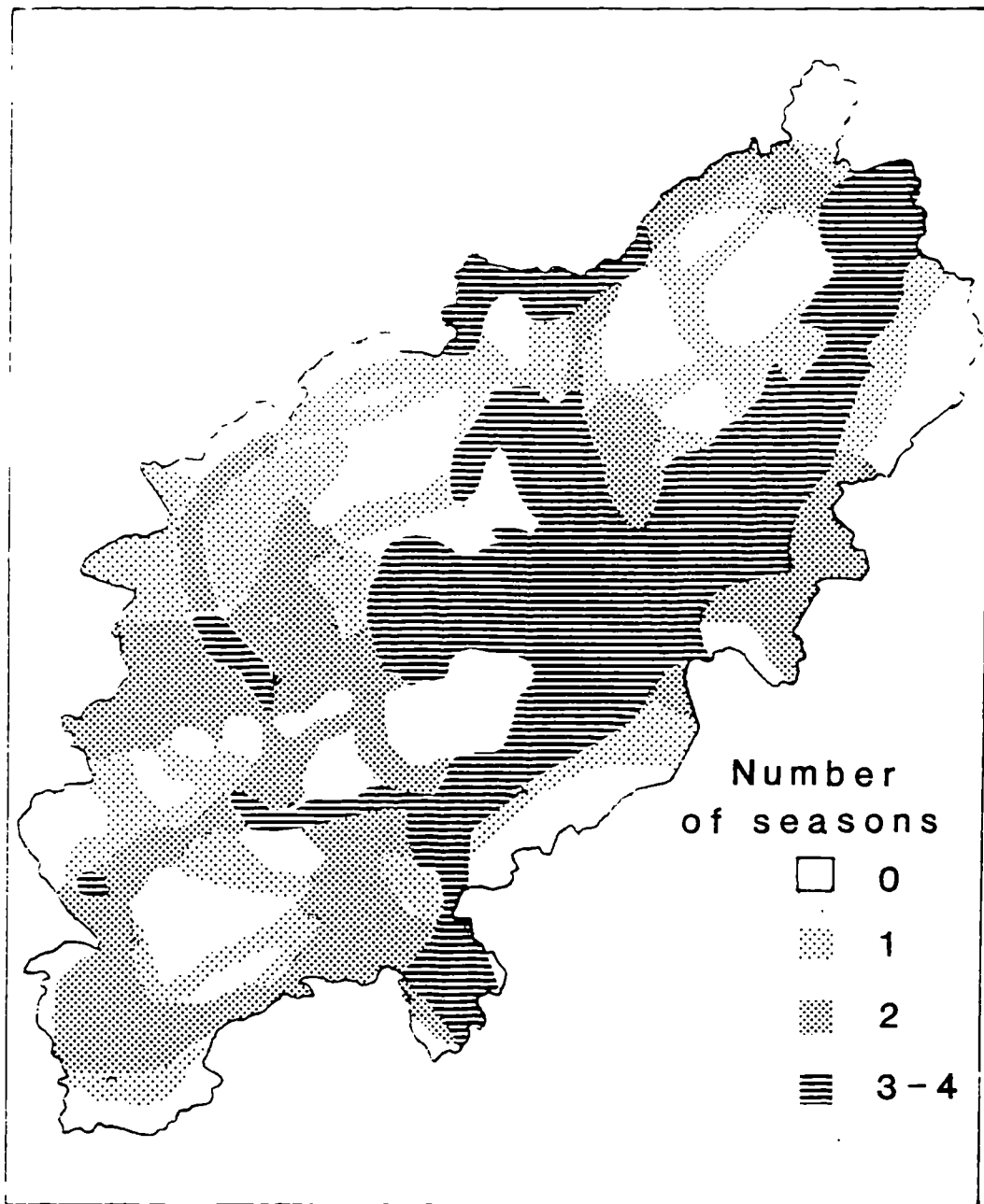

Figure 3.2 The air photographic reconnaissance history of Northamptonshire between 1979 and 1983 (data from Brown 1980; 1981; 1982; 1983).

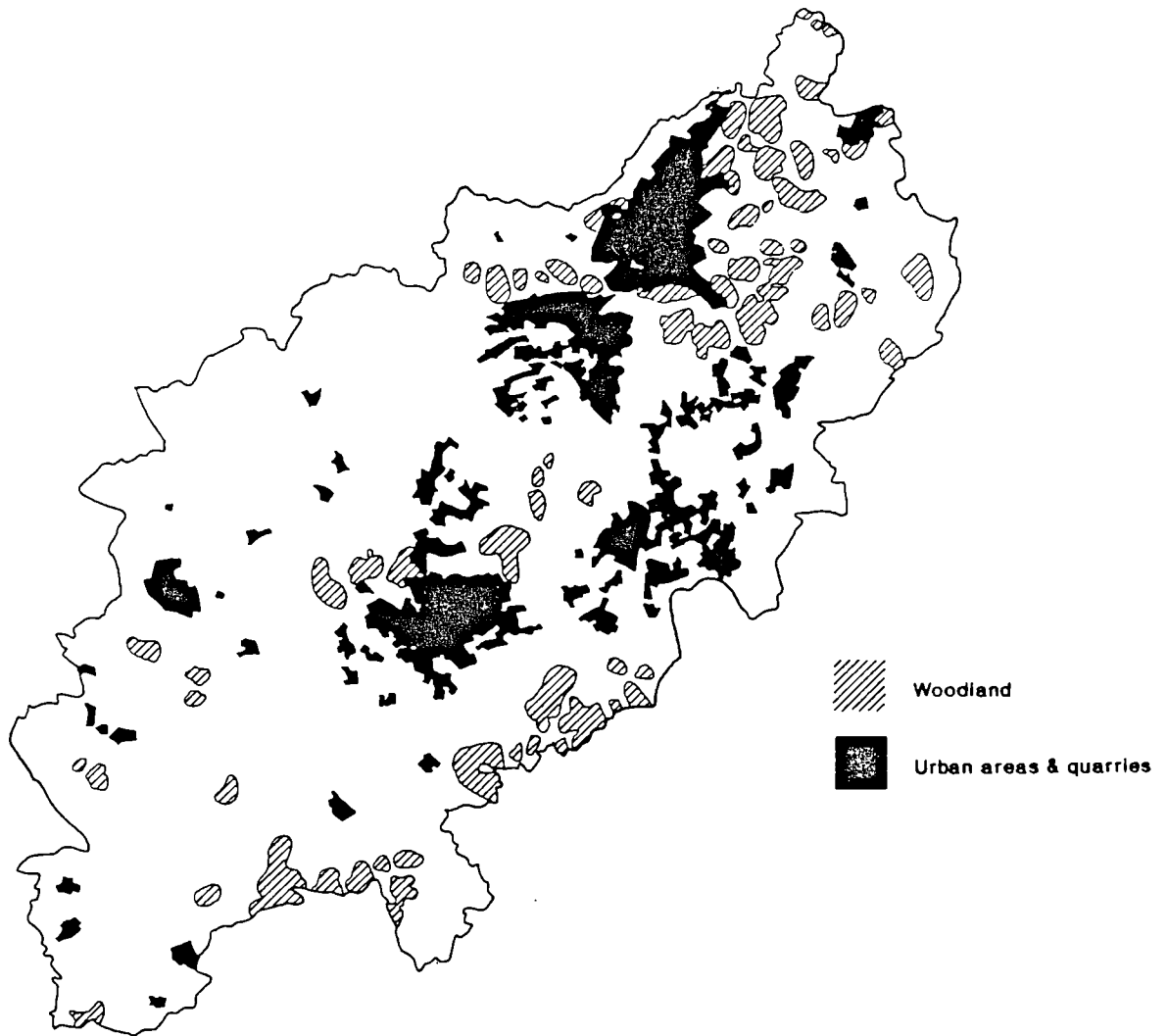

Figure 3.3 Map of Northamptonshire showing areas of destruction through mineral extraction and urban development (black) and areas of extensive woodland (hachured). Data from Foard (1979) with additions.

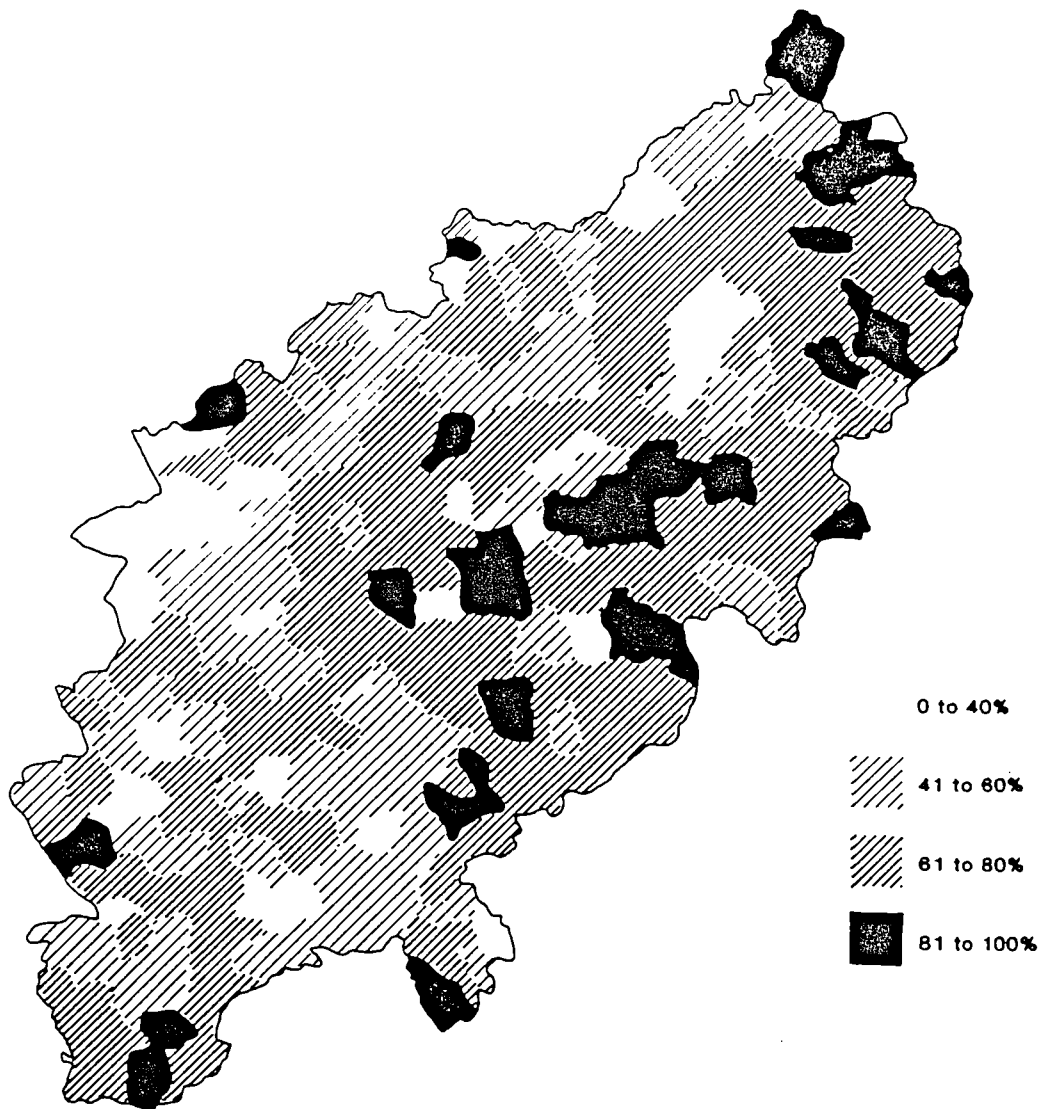

Figure 3.4 The proportion of available agricultural land under arable and temporary pasture in Northamptonshire in 1979 (after Foard 1979, fig. 13).

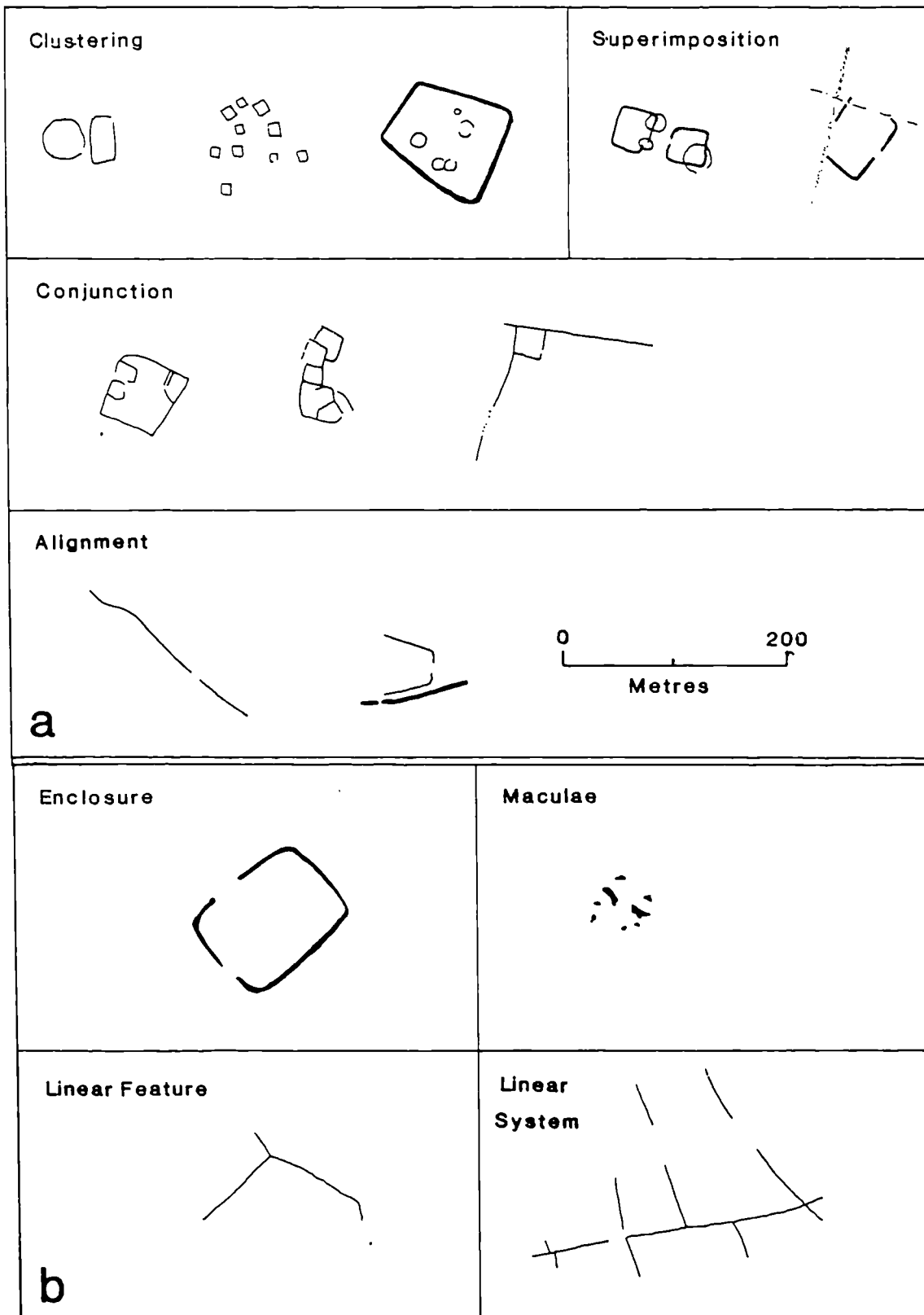

Figure 3.5 a) The four types of elementary structural relationships used for analysing air photographs (after Whimster 1989, fig. 21 with additions), and b) examples of the four site types used by the RCHM Air Photographic Unit for morphological classification.

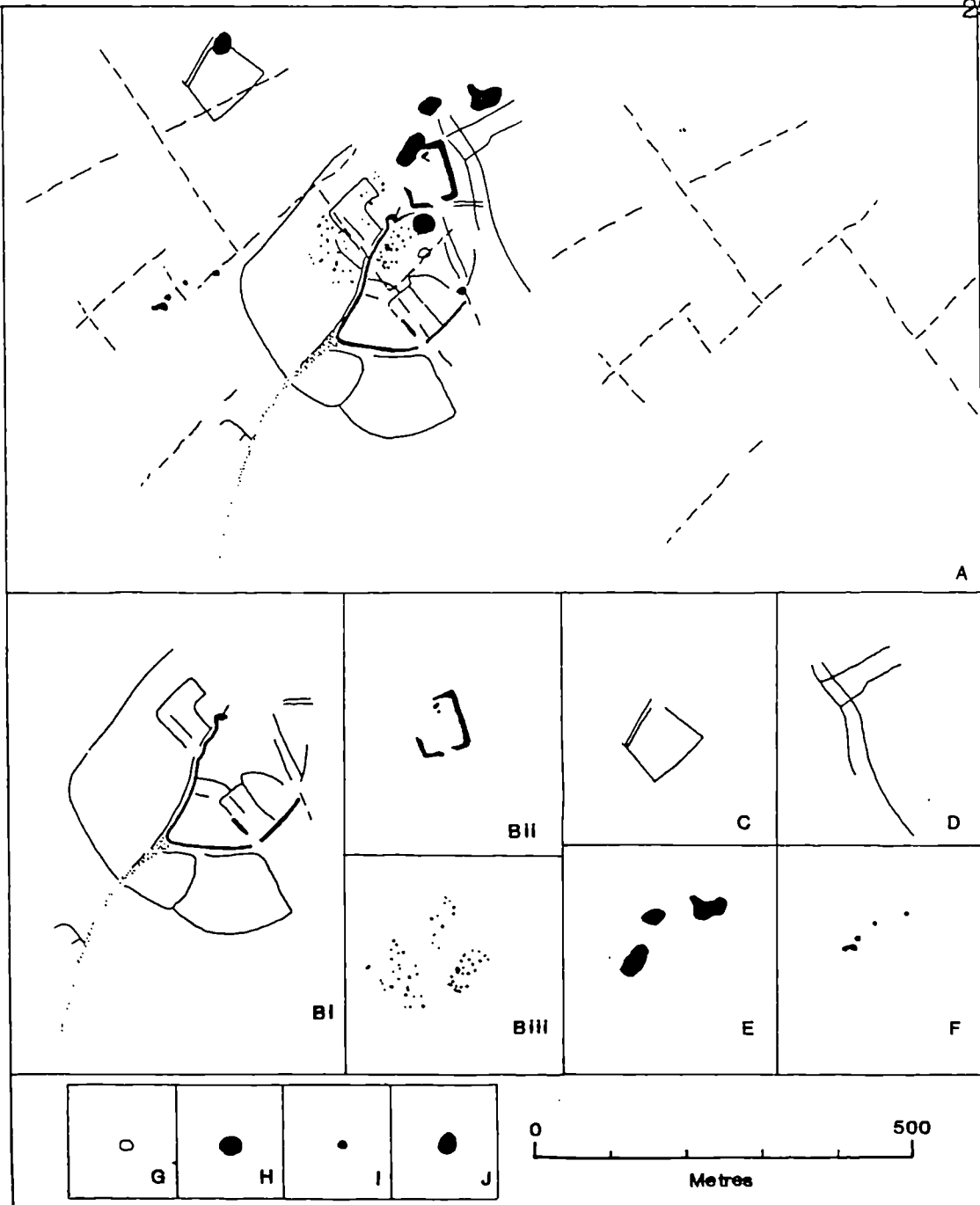

Figure 3.6 An example of site classification using MORPH on a crop mark complex in Kent. A and Bi are considered linear systems, Bii, C, and G are enclosures, D a linear feature, and Biii, E, F, H, I, and J are maculae (from Edis *et al.* 1989, fig. 2).

<p>A (Fig. 3.6 Bi)</p> <p>TYPE: Linear system</p> <p>PATTERN: Accreted</p> <p>SHAPE: Mixed</p> <p>FORM: Ditch/foundation</p> <p>CONTINUITY: Continuous</p> <p>TRACKWAYS: Unit defined</p> <p>ENCLOSURE</p> <p>COMPLEX?: Yes</p> <p>No. OF UNITS: 5?</p> <p>UNIT SIZE: Not definable</p>	<p>B (Fig 3.6 Bii)</p> <p>TYPE: " Enclosure</p> <p>LINEARITY: Rectilinear</p> <p>SYMMETRY: Symmetric</p> <p>SHAPE: Rectangular</p> <p>ELONGATED: Yes</p> <p>SIDES: Straight</p> <p>CORNERS: Curved</p> <p>FORM: Ditch</p> <p>CONDITION: Incomplete</p> <p>CONTINUOUS: No</p> <p>SIZE (L): 100m</p> <p>SIZE (B): 60m</p> <p>INTERNAL</p> <p>FEATURES: Non structural</p>
<p>C (Bi)</p> <p>CATEGORY Crop mark</p> <p>GROUPING</p> <p>CONJUNCTION: Accreted</p> <p>ALIGNMENT: Parallel & Perpendicular</p> <p>CLUSTERING: Linear</p> <p>LINEAR ELEMENTS</p> <p>FORM: Ditch & foundation</p> <p>SHAPE: Mixed</p> <p>WIDTH; 1-5m, 2-8m</p> <p>CONTINUITY: Continuous</p> <p>MACULAE</p> <p>NUMBER: None</p> <p>FORM:</p> <p>SHAPE:</p> <p>SIZE:</p>	<p>D (Bii)</p> <p>CATEGORY Crop mark</p> <p>GROUPING</p> <p>CONJUNCTION: None</p> <p>ALIGNMENT: In line</p> <p>CLUSTERING: Nucleated</p> <p>LINEAR ELEMENTS</p> <p>FORM: Ditch</p> <p>SHAPE: Straight & Angular bend</p> <p>WIDTH; 10m</p> <p>CONTINUITY: Interrupted</p> <p>MACULAE</p> <p>NUMBER: 2</p> <p>FORM: Cut</p> <p>SHAPE: Oblong</p> <p>SIZE: Small & medium</p>

Figure 3.7 The classification of sites Bi and Bii from figure 3.6 using MORPH (A & B) and a simple non-hierarchical landscape-based method (C & D).

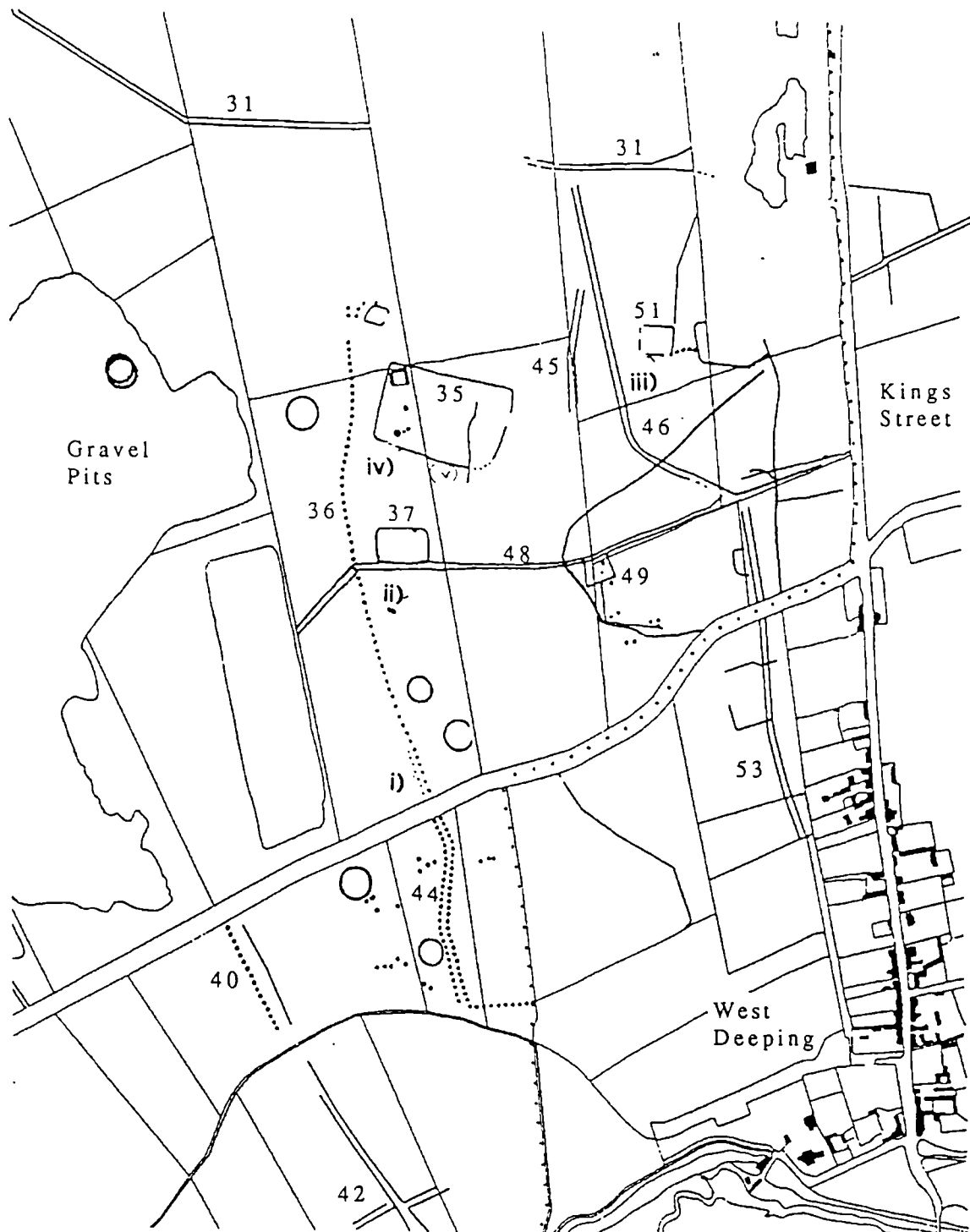

Figure 3.8 The Tallington/West Deeping area of the lower Welland valley showing selected landscape features and monument numbers from Bowen and Butler (1960), figure 7 with additions and alterations.

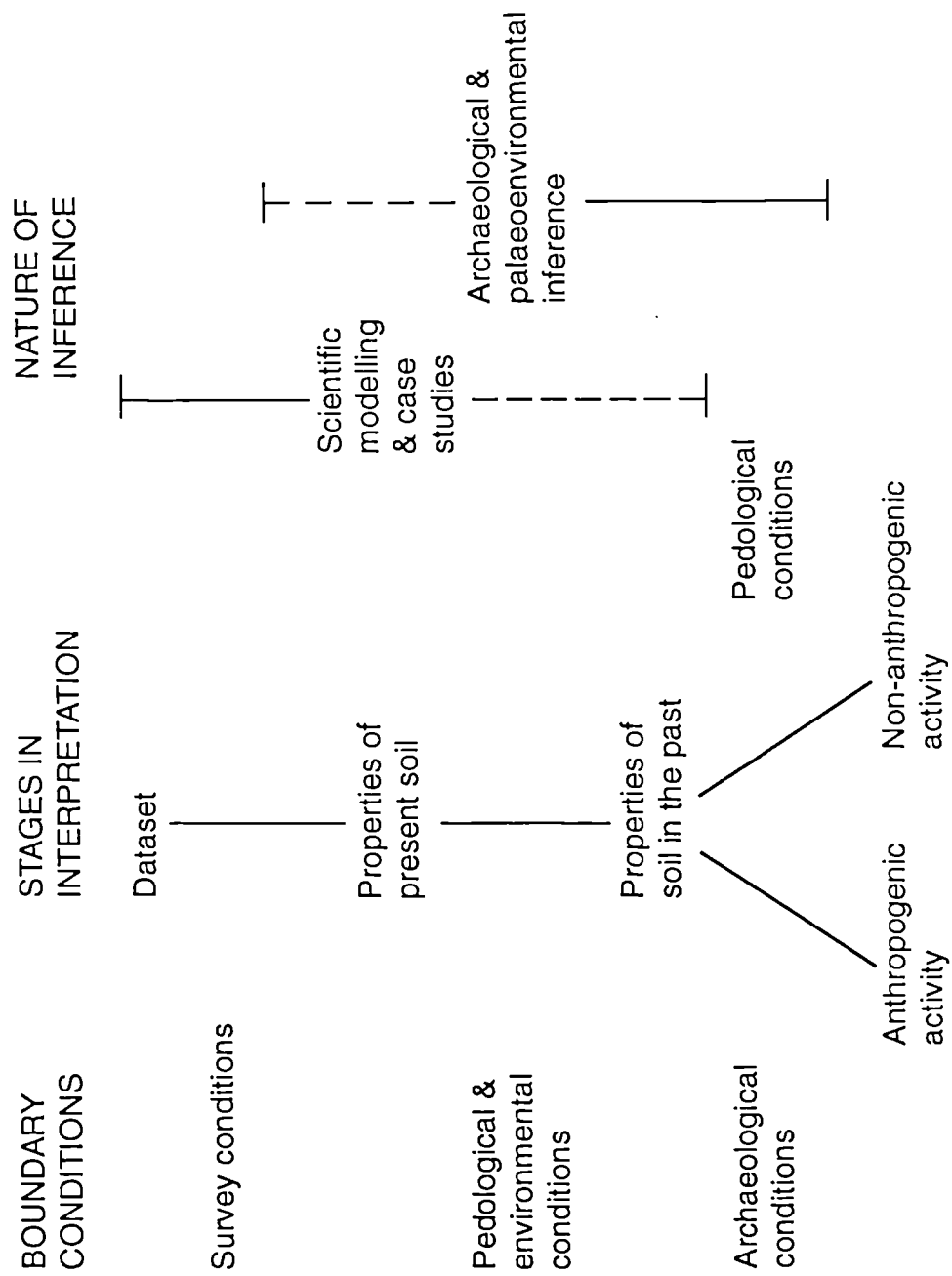

Figure 4.1 A Model for the interpretation of geopropection data

A) ARCHAEOLOGICAL CONDITIONS

Past human behaviour must be of a type that is likely to cause:

- i) stable change to soil conditions
- ii) change which is discernible from that created by non-archaeological causes
- iii) change which is spatially and/or chronologically separable from other archaeological events.

B) PEDOLOGICAL AND ENVIRONMENTAL CONDITIONS

The soil type studied must:

- i) be suitable for change in a way that is measurable
- ii) preserve the changes caused by archaeological action through time.

C) SURVEY CONDITIONS

The nature of the data recovered and analysed is affected by:

- i) the principles and technology of the equipment used
- ii) the design and layout of the survey
- iii) the methods of data storage and presentation used.

Figure 4.2 Boundary conditions affecting the recovery of archaeological information from geoprospection.

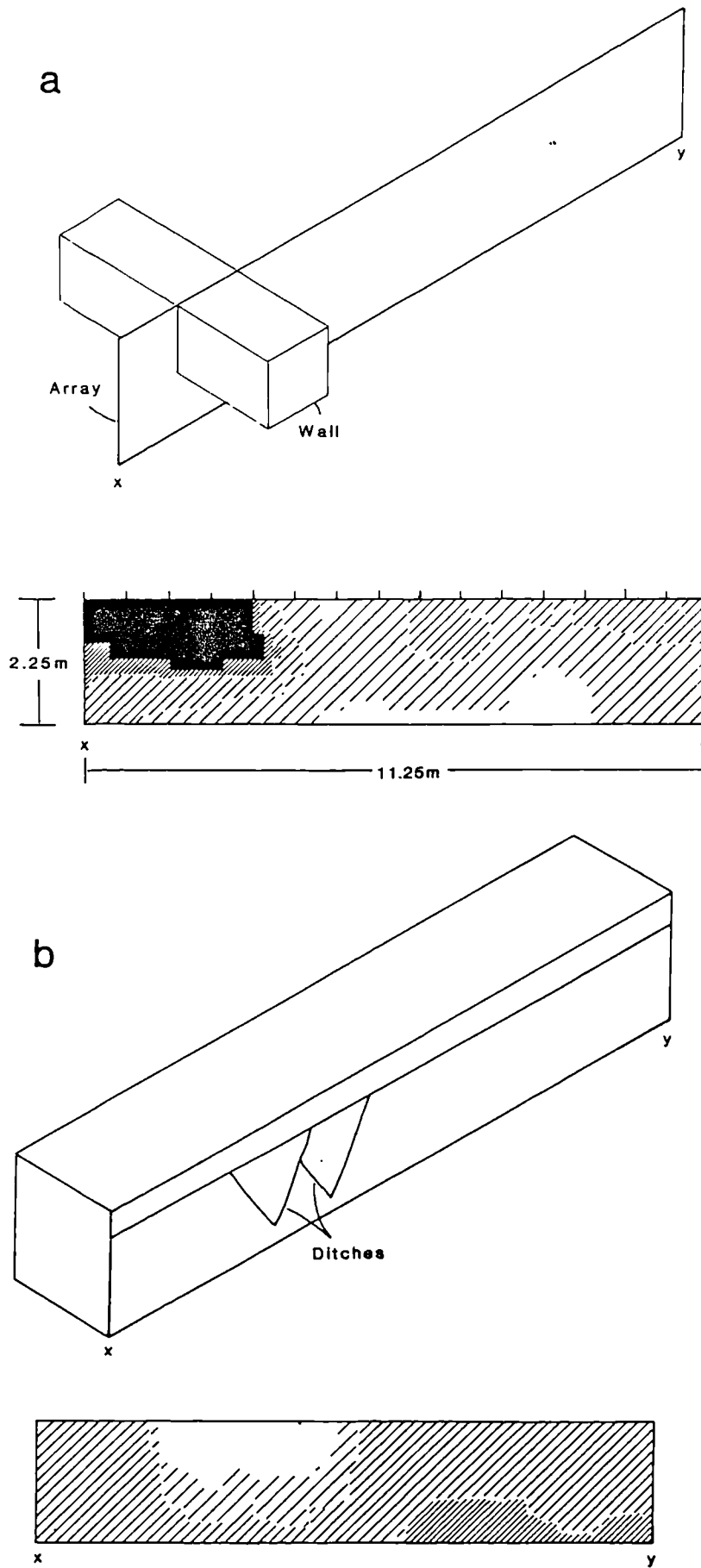

Figure 4.3 a) The cross-sectional signature of a high resistance structure (a wall) using resistivity tomography. b) A schematic diagram showing the tomography section for two intercutting low resistance structures (ditches), after Noel 1992, figures 62 & 63.

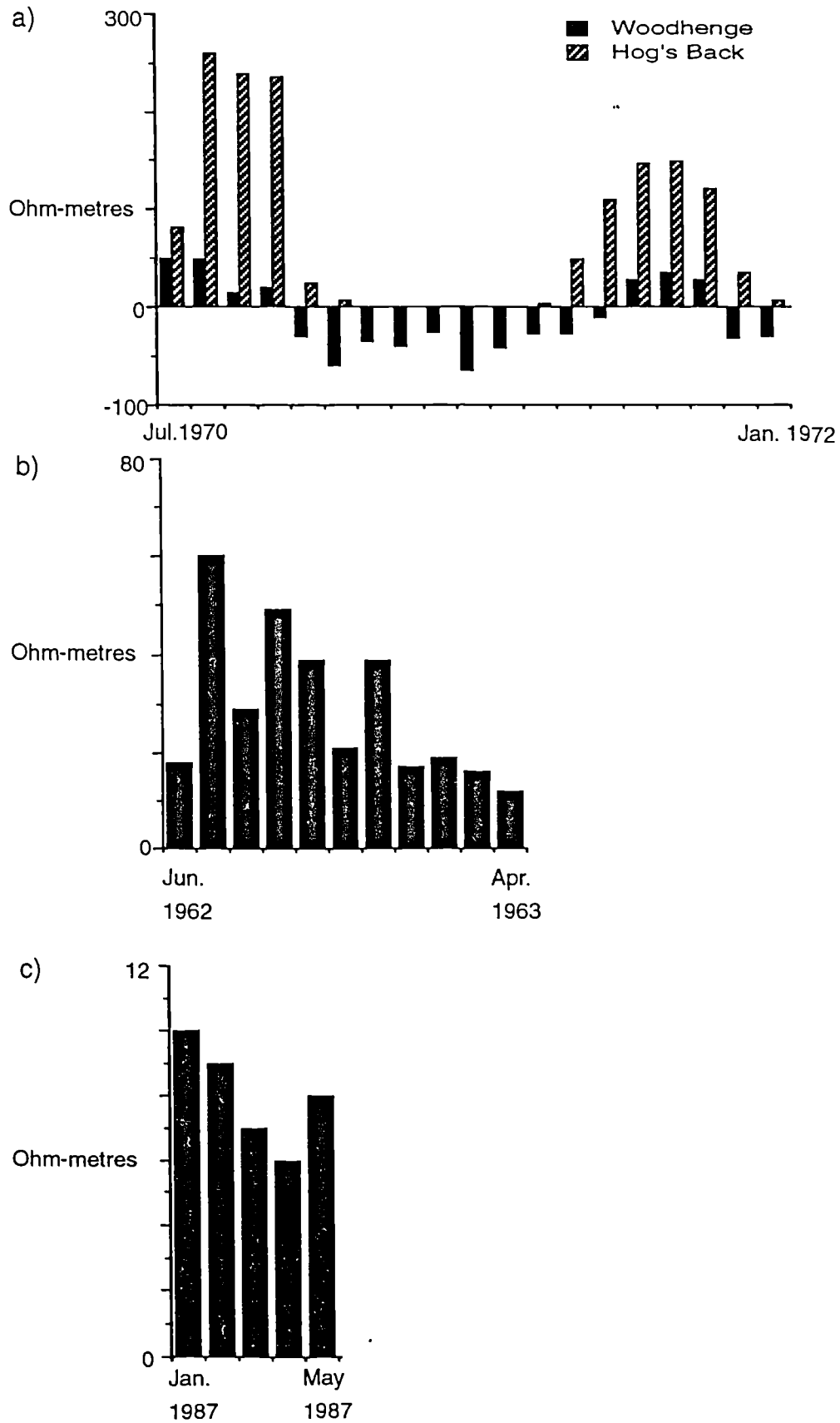

Figure 4.4 Three examples of the seasonal effects of rain on resistivity anomalies from a) chalk (Woodhenge & Hog's Back, Clark 1990, fig. 39), b) limestone (Garchy, Hesse 1966) and c) sandstone (Durham, Batt 1987).

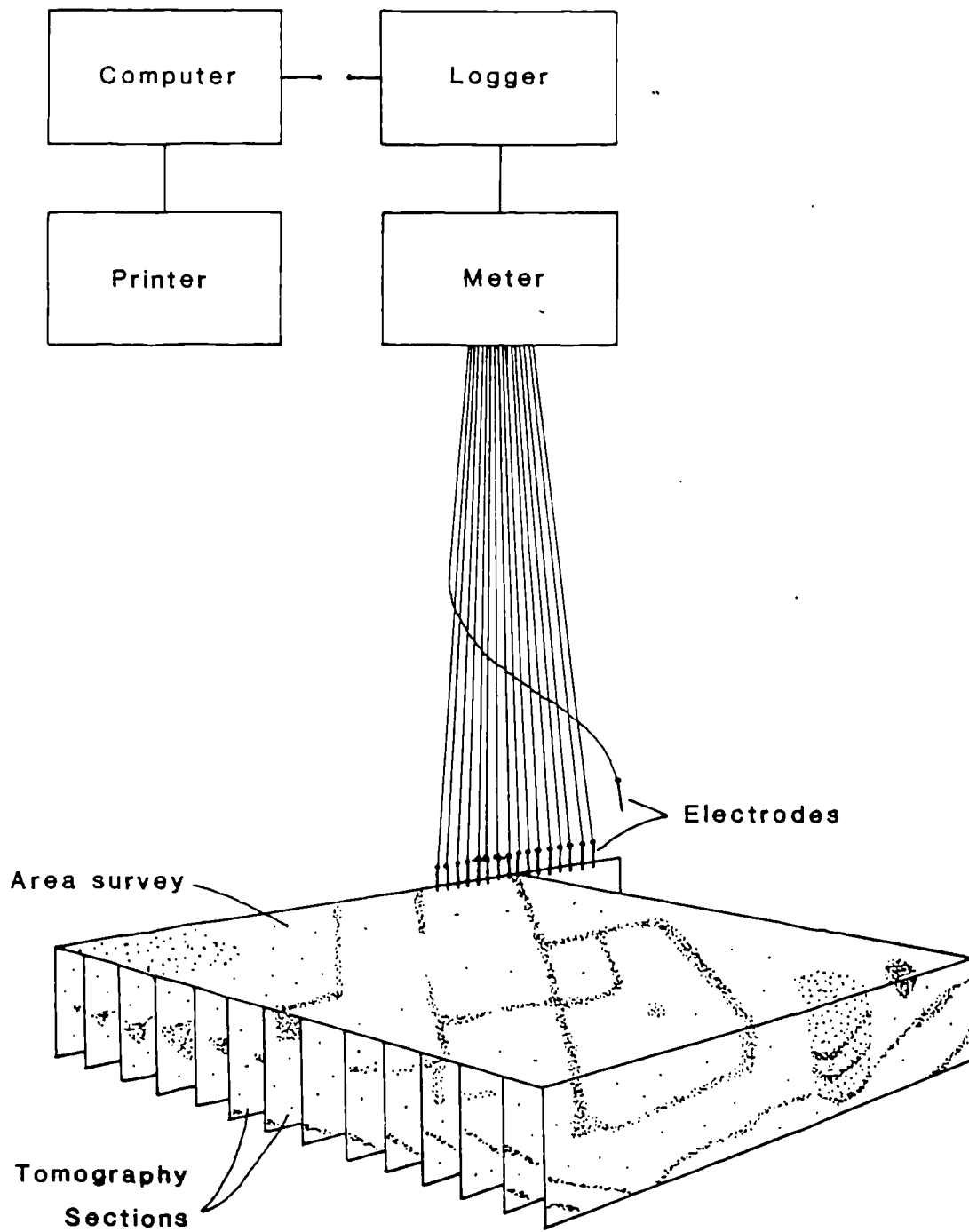

Figure 4.5 A simplified diagram showing how, by combining the results of conventional resistivity area survey with tomographic sections, a three-dimensional model of electrical anomalies can be constructed (from Clark 1990, fig. 48).

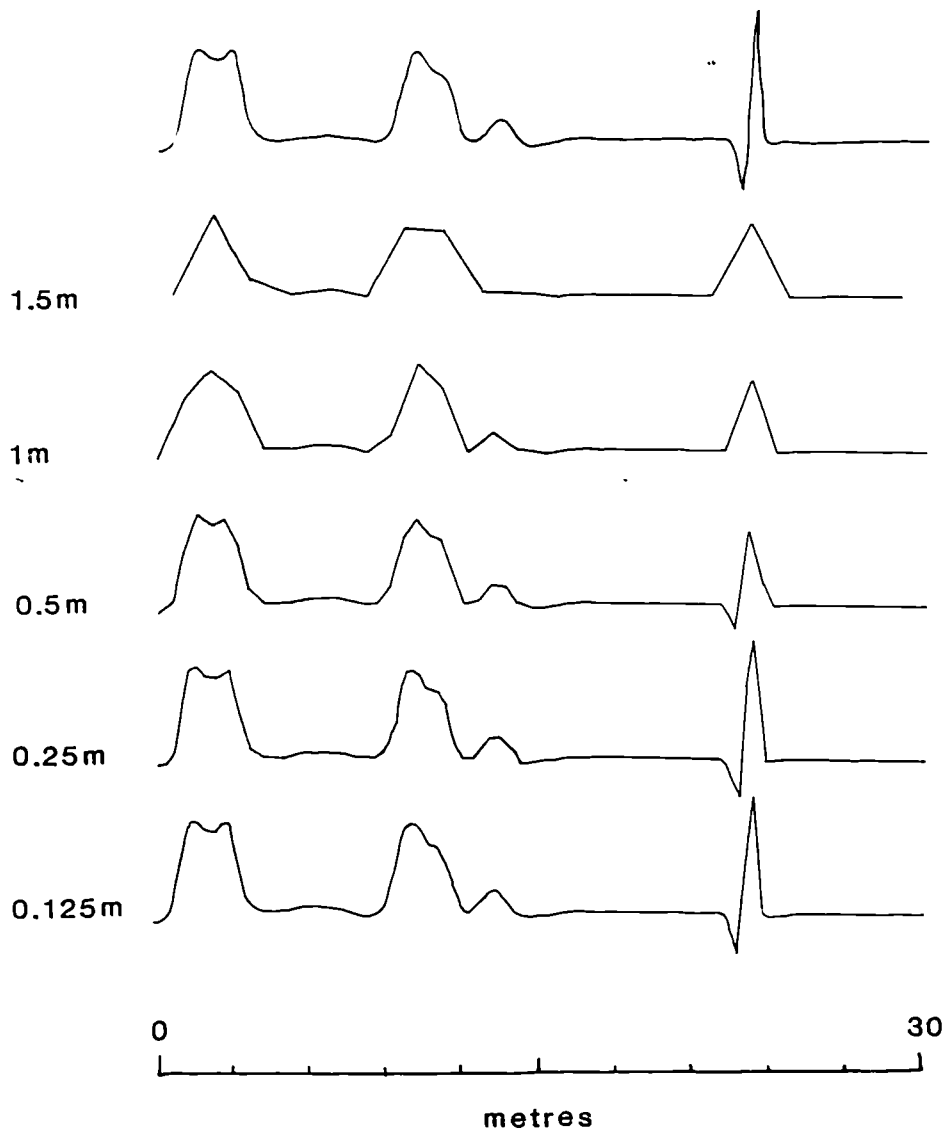

Figure 4.6 The effect of changing recording intervals on the resolution of magnetometry profiles. A continuously recorded trace from one transect taken over two Roman pottery kilns (shown top, left and centre) has a distinctive profile when compared to a modern iron object (top right). This only becomes apparent when the recording interval of the survey is 0.5 metres or less (from Clark 1990, fig. 62).

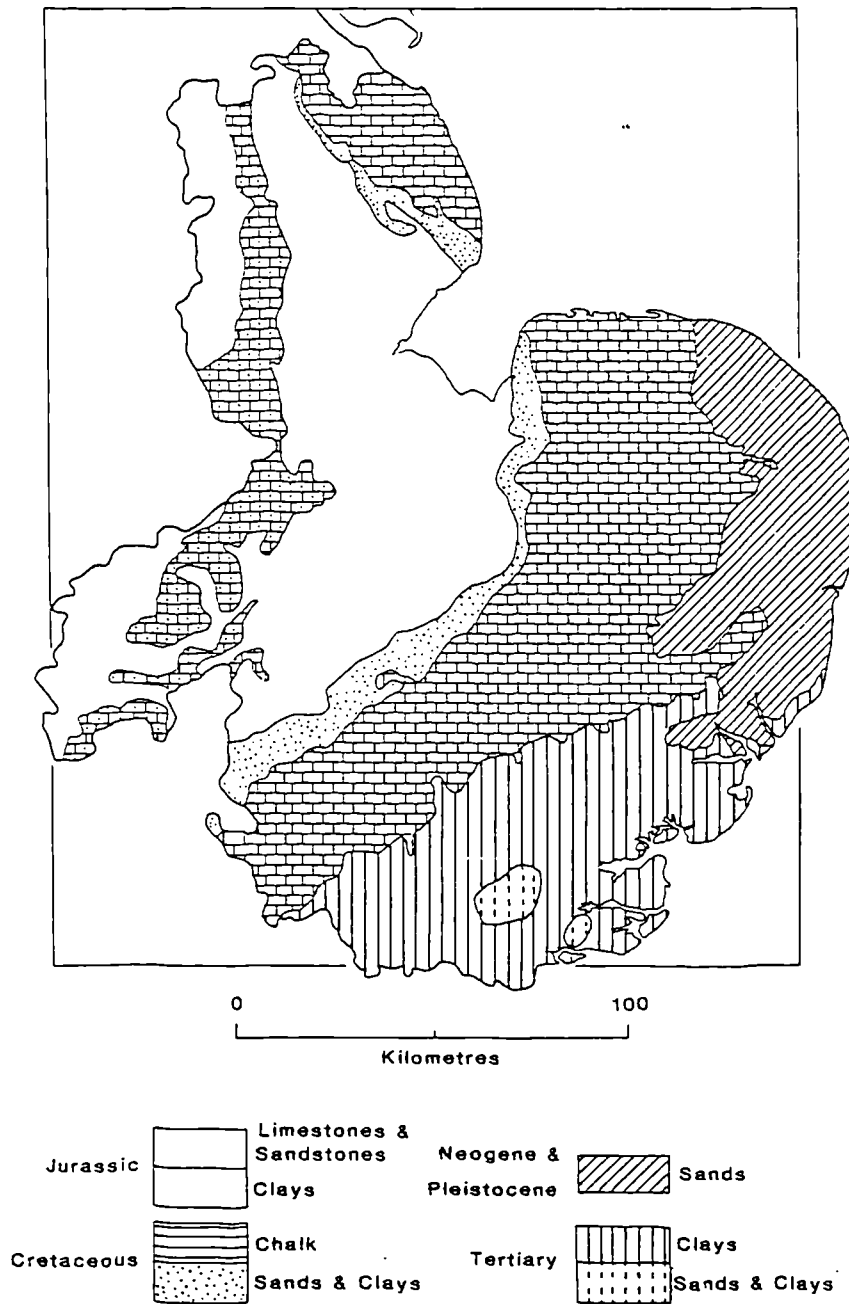

Figure 4.7 Map of the solid geology of eastern England (from Hodge *et al.* 1984, fig. 3). Areas with Jurassic geology generally respond well to magnetometry as do those with Cretaceous sands and Tertiary sands and clays. The chalk and Pleistocene sands of East Anglia have low magnetic susceptibility and thus poorer anomaly definition. The presence of extensive drift deposits in this area further complicates interpretation, a problem that is not significant in Northamptonshire (marked in outline) where they are largely absent.

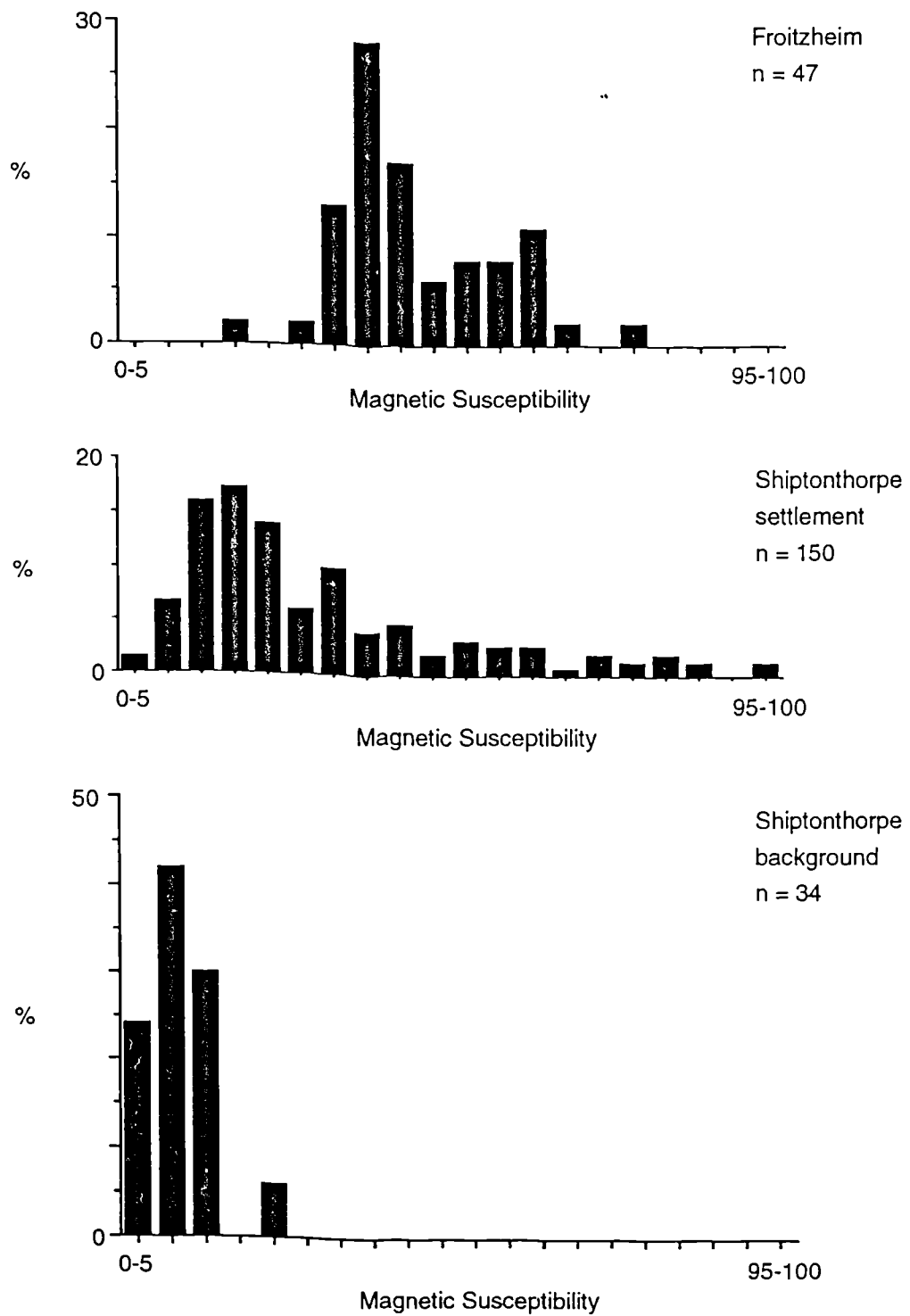

Figure 4.8 Percentage frequency distributions for magnetic susceptibility samples (in 10^{-6} emu g^{-1}) from Froitzheim (Scollar 1990, 402) and Shiptonthorpe background survey and settlement area (Taylor 1989, appendix 1), where n = the number of samples.

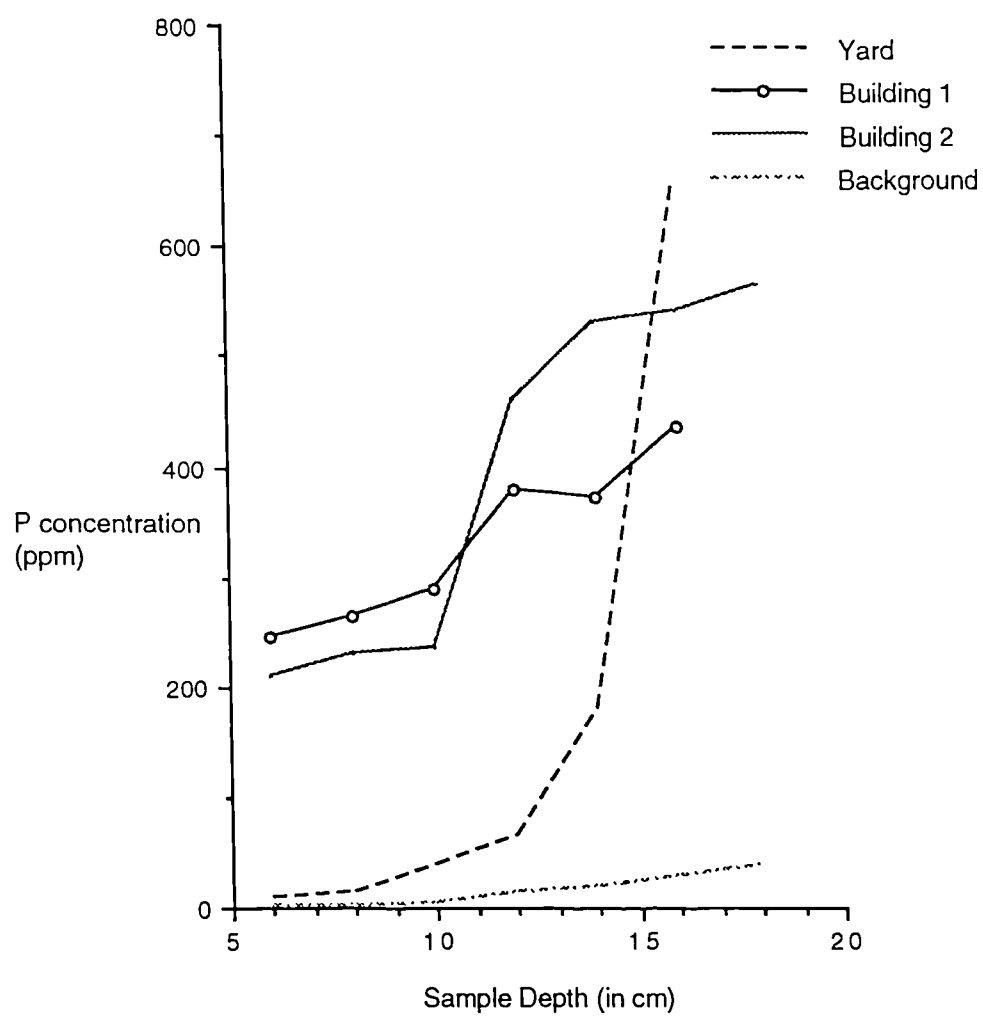

Figure 4.9 Soil phosphate profiles at Woolaw, Northumberland showing clear distinctions between strata from different archaeological areas (after Clogg & Ferrell 1992, fig. 1).

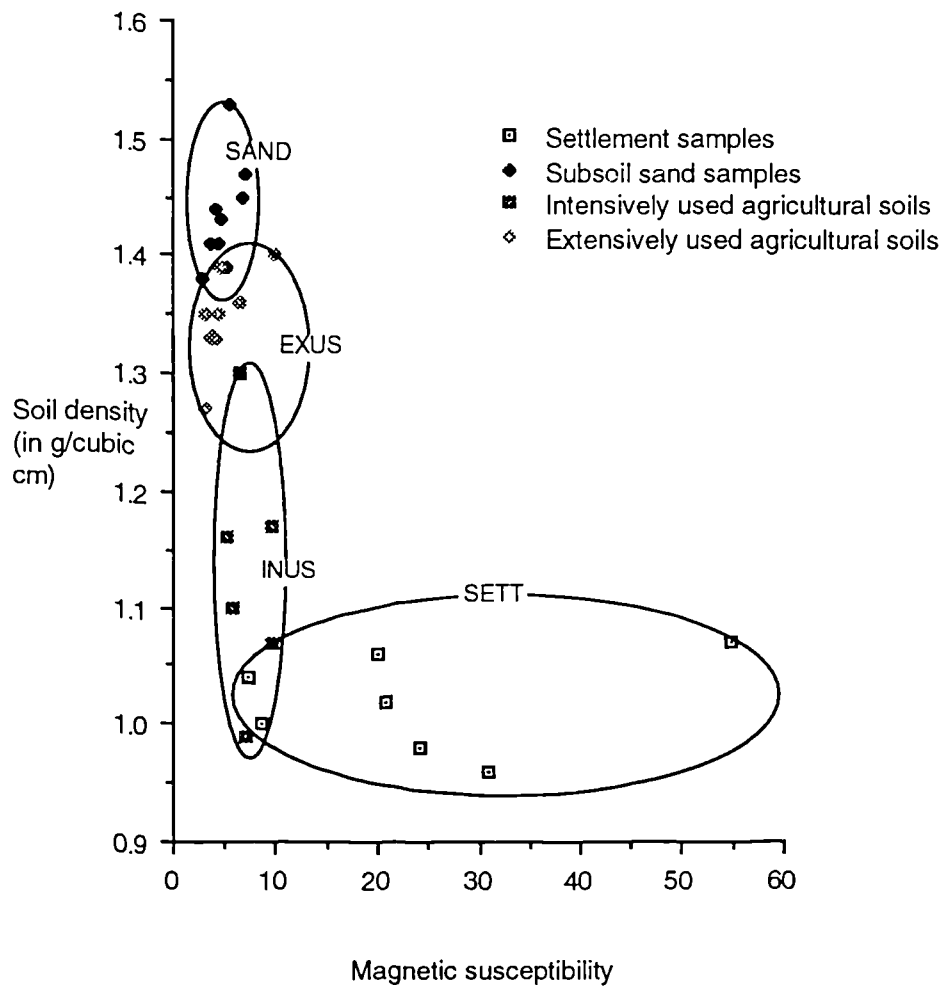

Figure 4.10 Scatter plot showing how soils from specific land use categories are distinctive when represented by two-dimensional projections using magnetic susceptibility and soil density. Further variables create further dimensions and can identify clear finger prints for soils from specific contexts (from Freij 1988, table 1).

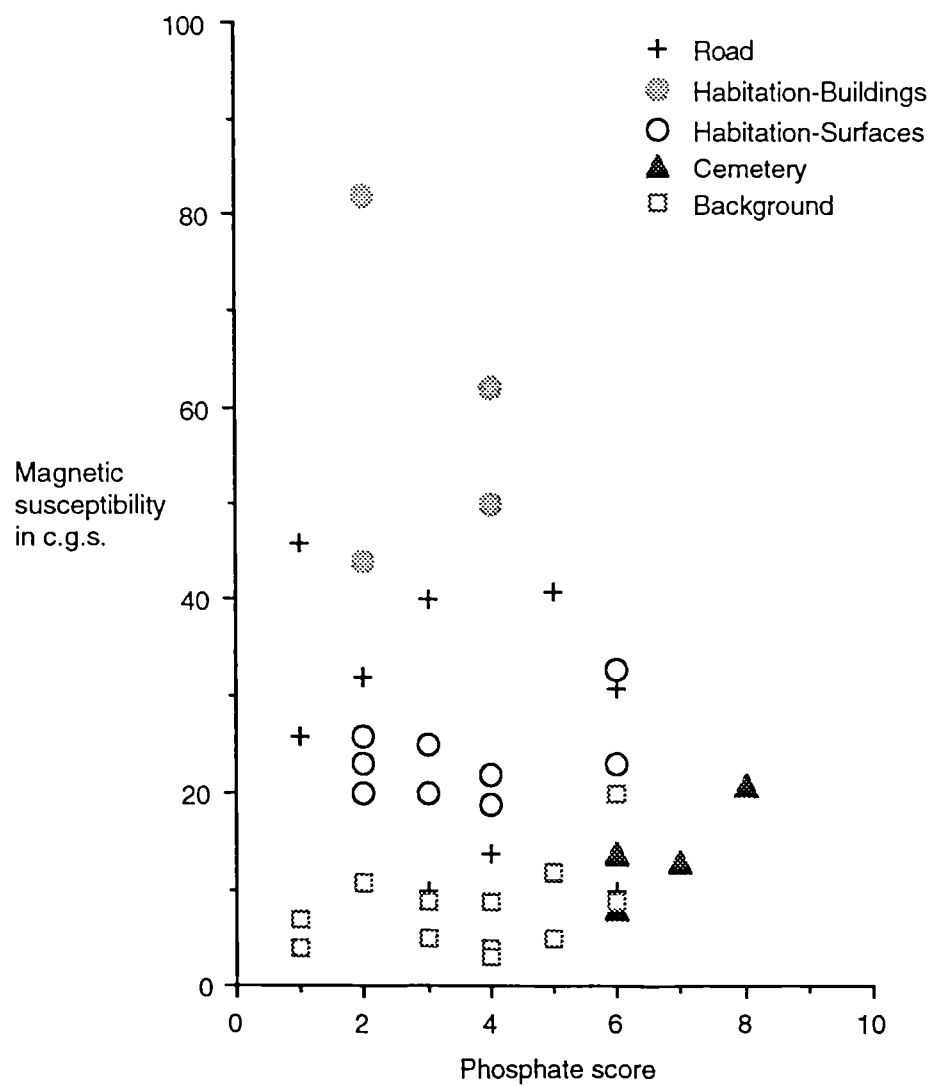

Figure 4.11 Phosphate and magnetic susceptibility scores for samples from classified contexts at Shiptonthorpe (data from Taylor 1989, appendices 1 & 2). Habitation-Buildings samples were taken from inside known Roman buildings, Habitation-Surfaces samples came from surfaces outside them.

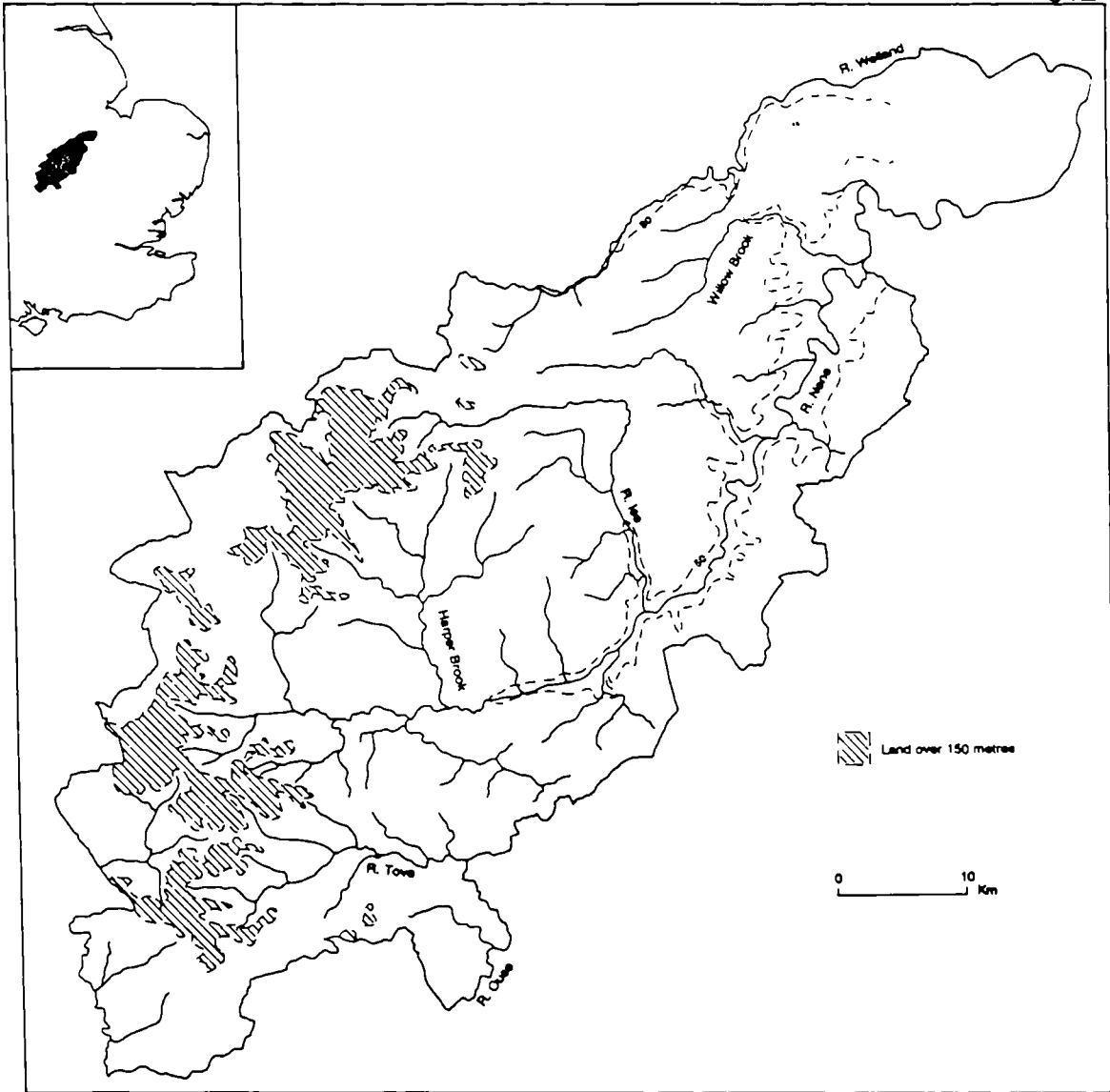

Figure 5.1 Location map of the study region.

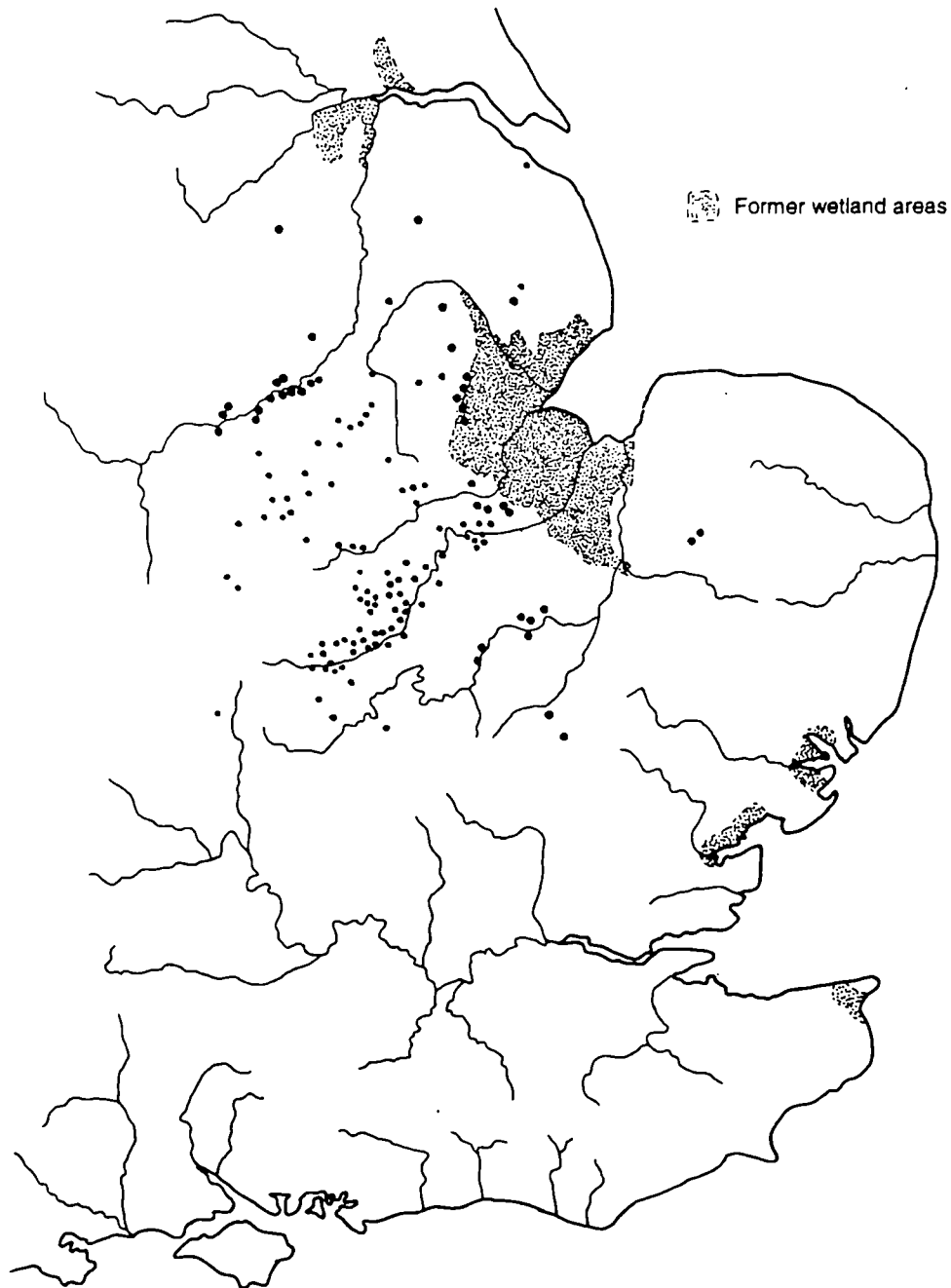

Figure 5.2 The distribution of Scored wares in eastern England (after Elsdon 1992).

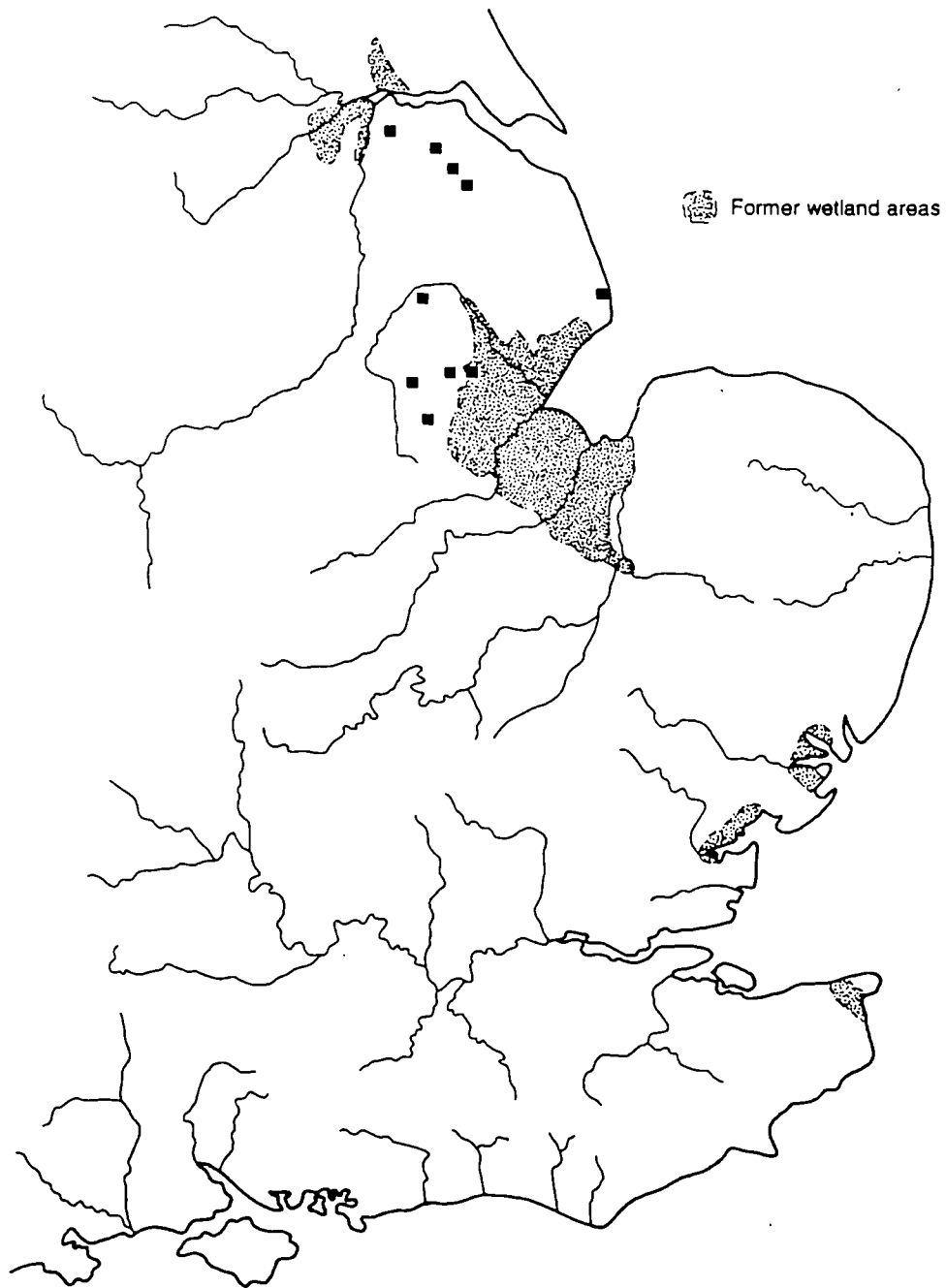

Figure 5.3 The distribution of Dragonby/Sleaford wares in eastern England (after Cunliffe 1991, fig. 4.9).

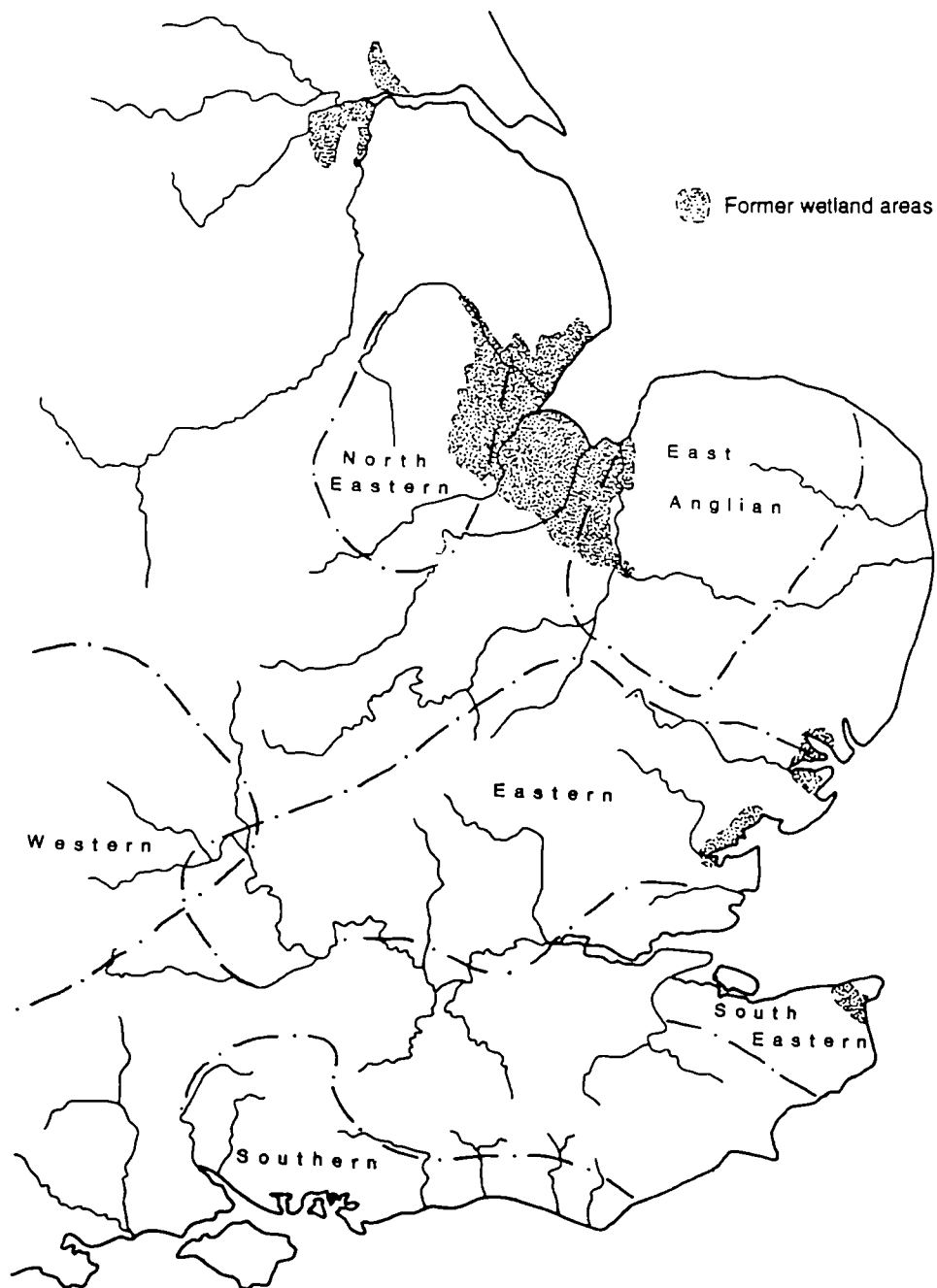

Figure 5.4 The coinage zones of the late iron age in eastern England (after Haselgrove 1987)

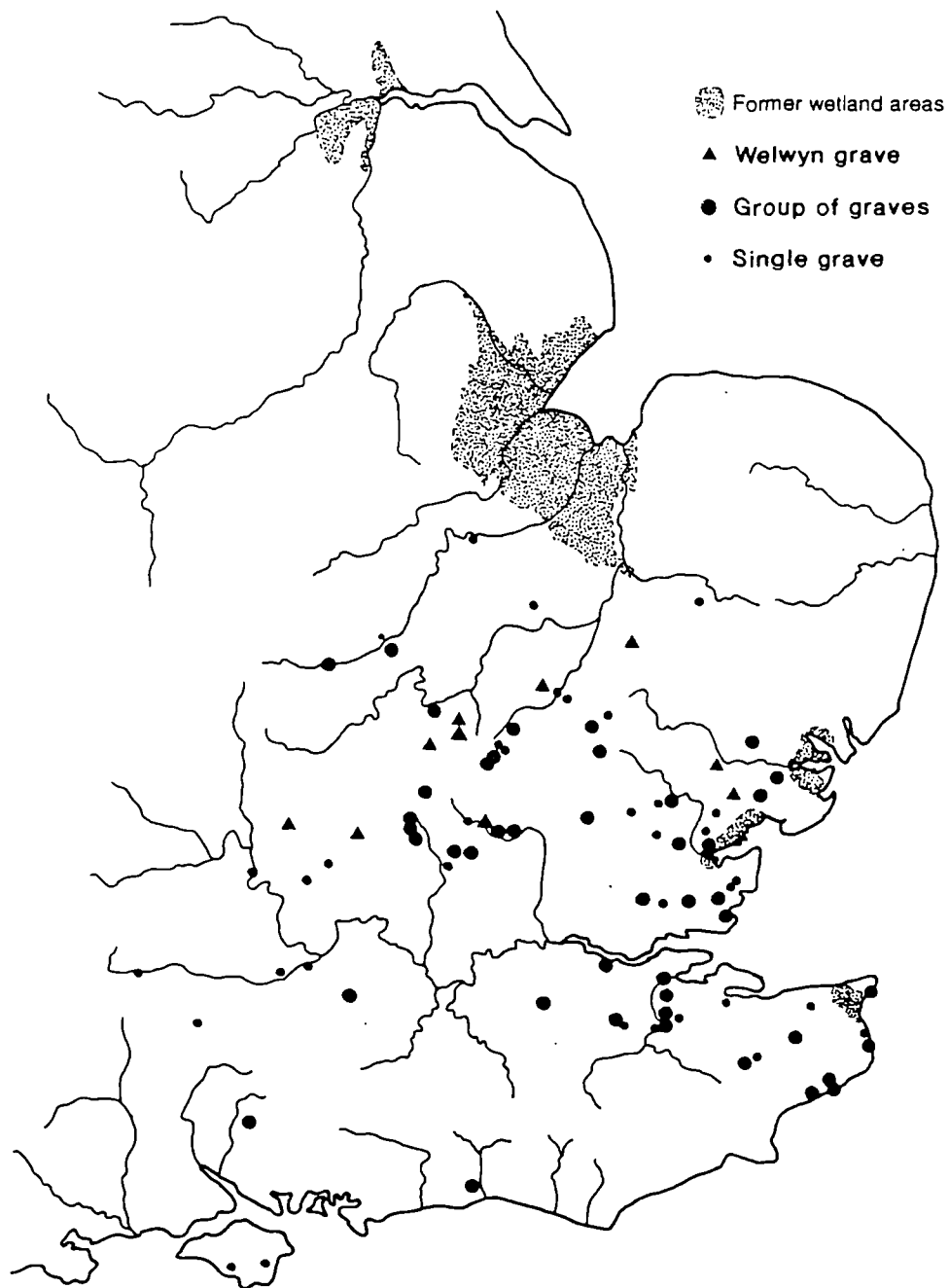

Figure 5.5 The distribution of La Tene III burials in eastern England (after Whimster 1981).

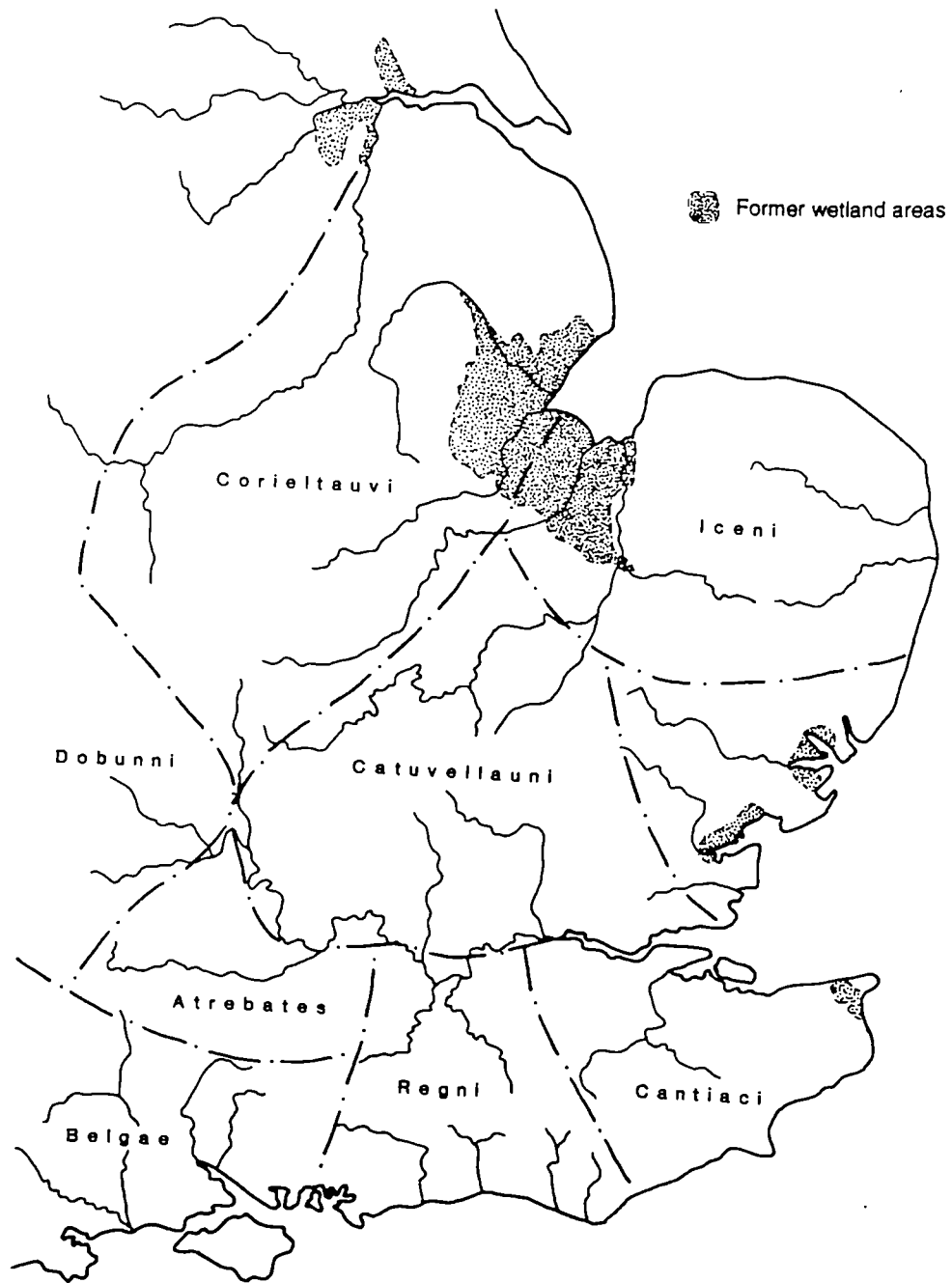

Figure 5.6 The civitates of eastern England (after Millett 1990).

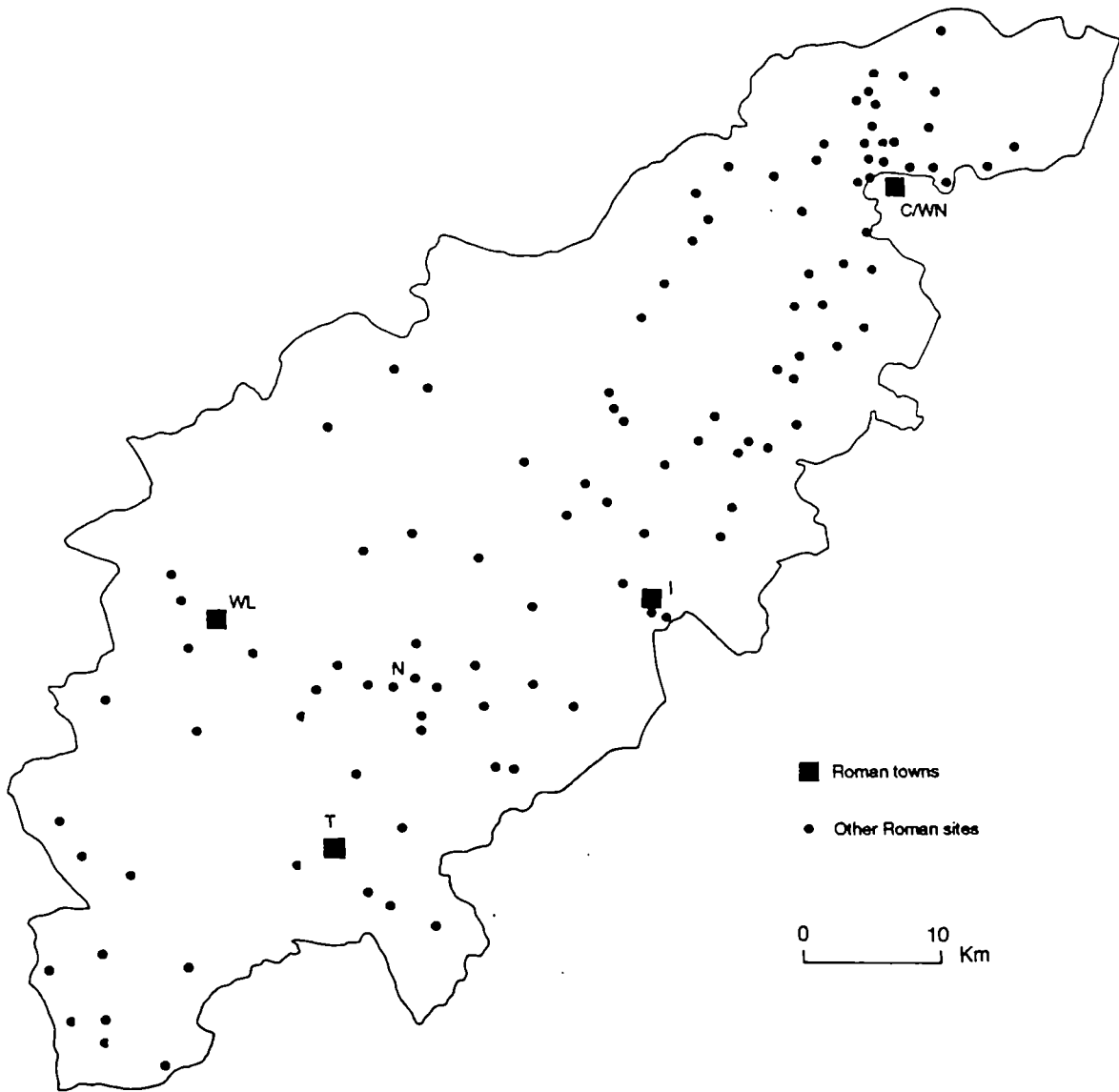

Figure 5.7 Known Roman sites at the time of Haverfield's (1902) survey.

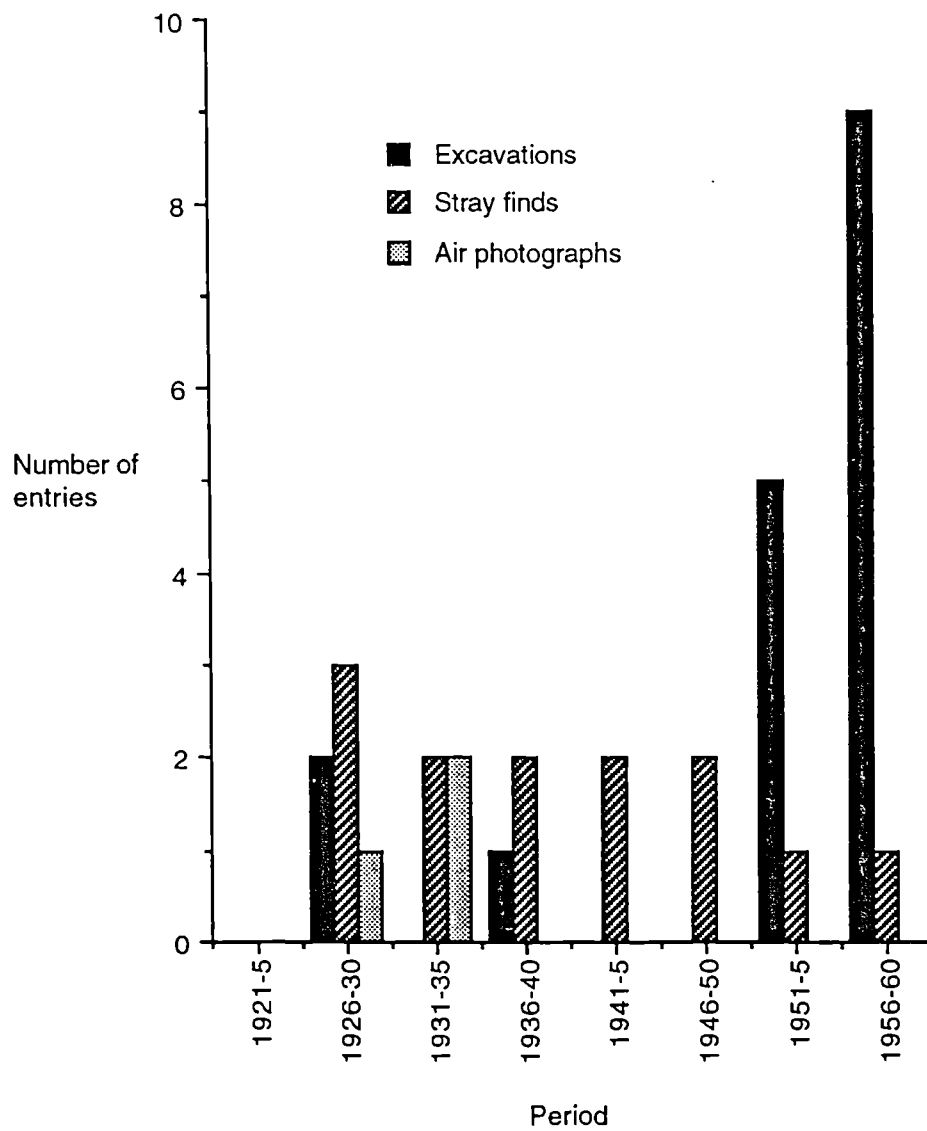

Figure 5.8 The number of instances of excavations, stray finds and air photographic surveys from Northamptonshire recorded in the *Journal of Roman Studies* between 1921 and 1960.

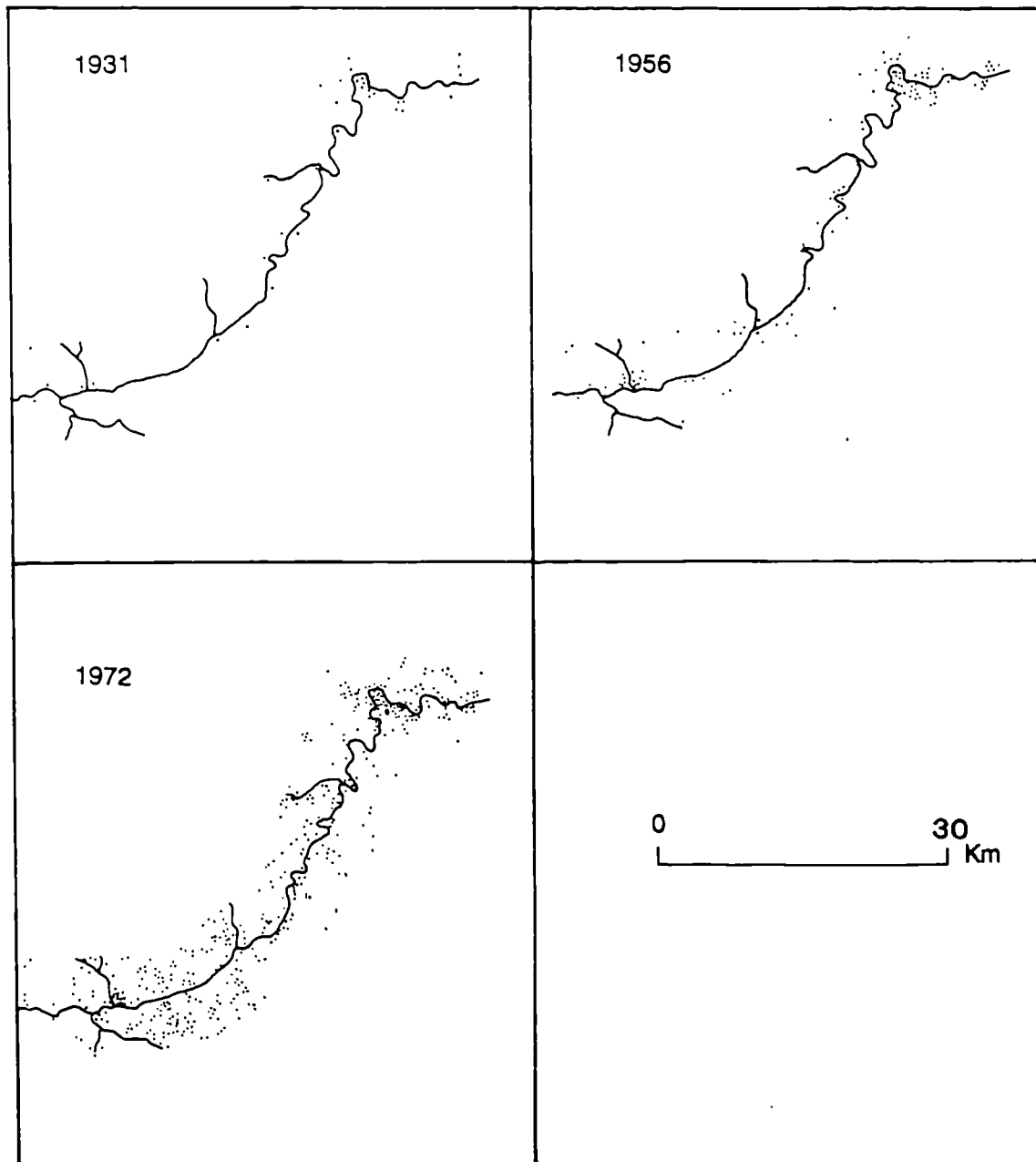

Figure 5.9 The distribution of known Roman sites in the Nene Valley in 1931, 1956 and 1972 (after Taylor 1975).

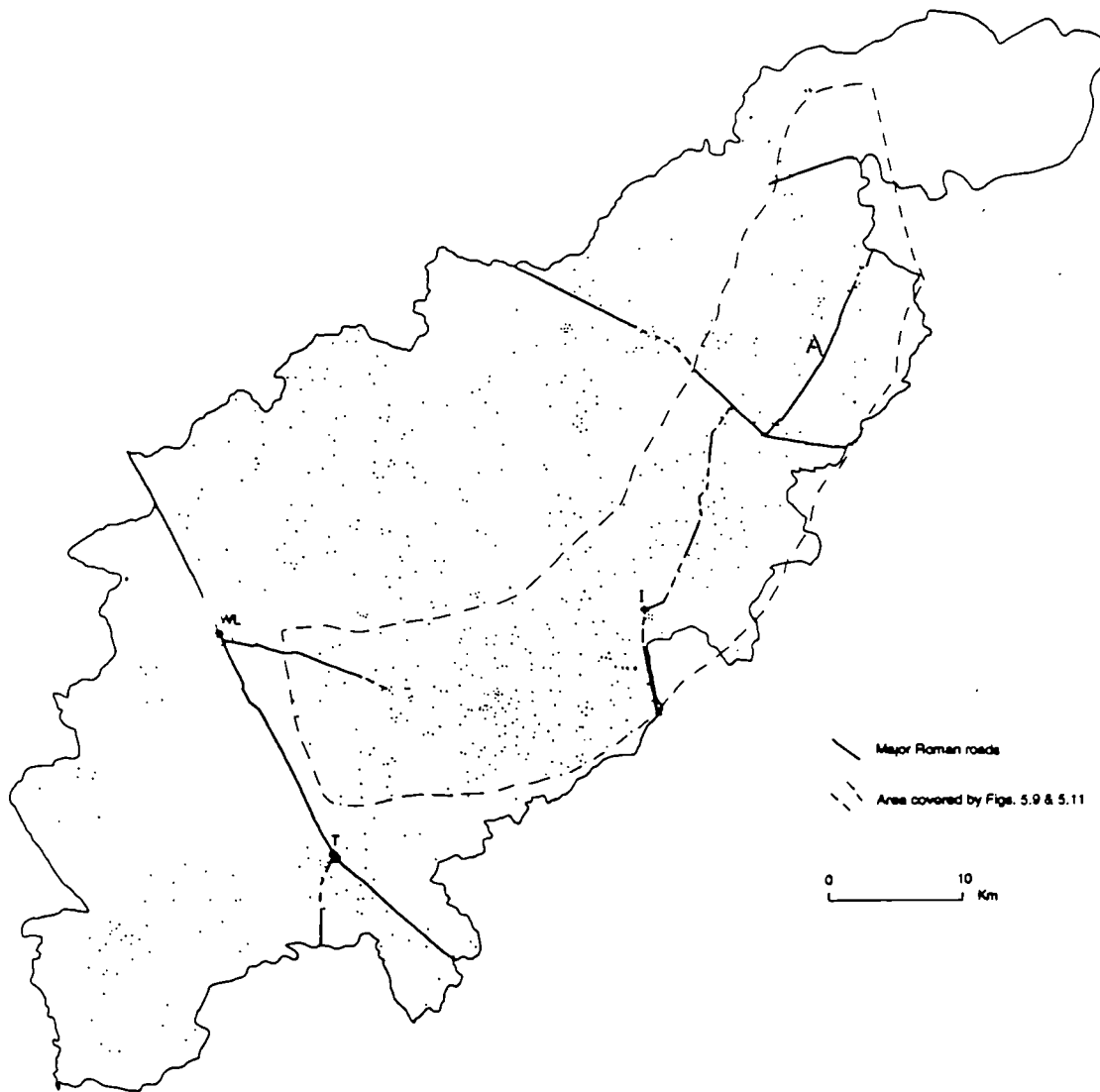

Figure 5.10 The distribution of known Roman sites in Northamptonshire in 1980 (after RCHM 1980).



Figure 5.11 Roman sites discovered between 1956 and 1980 in the Nene Valley compared to areas of urban development and quarrying.

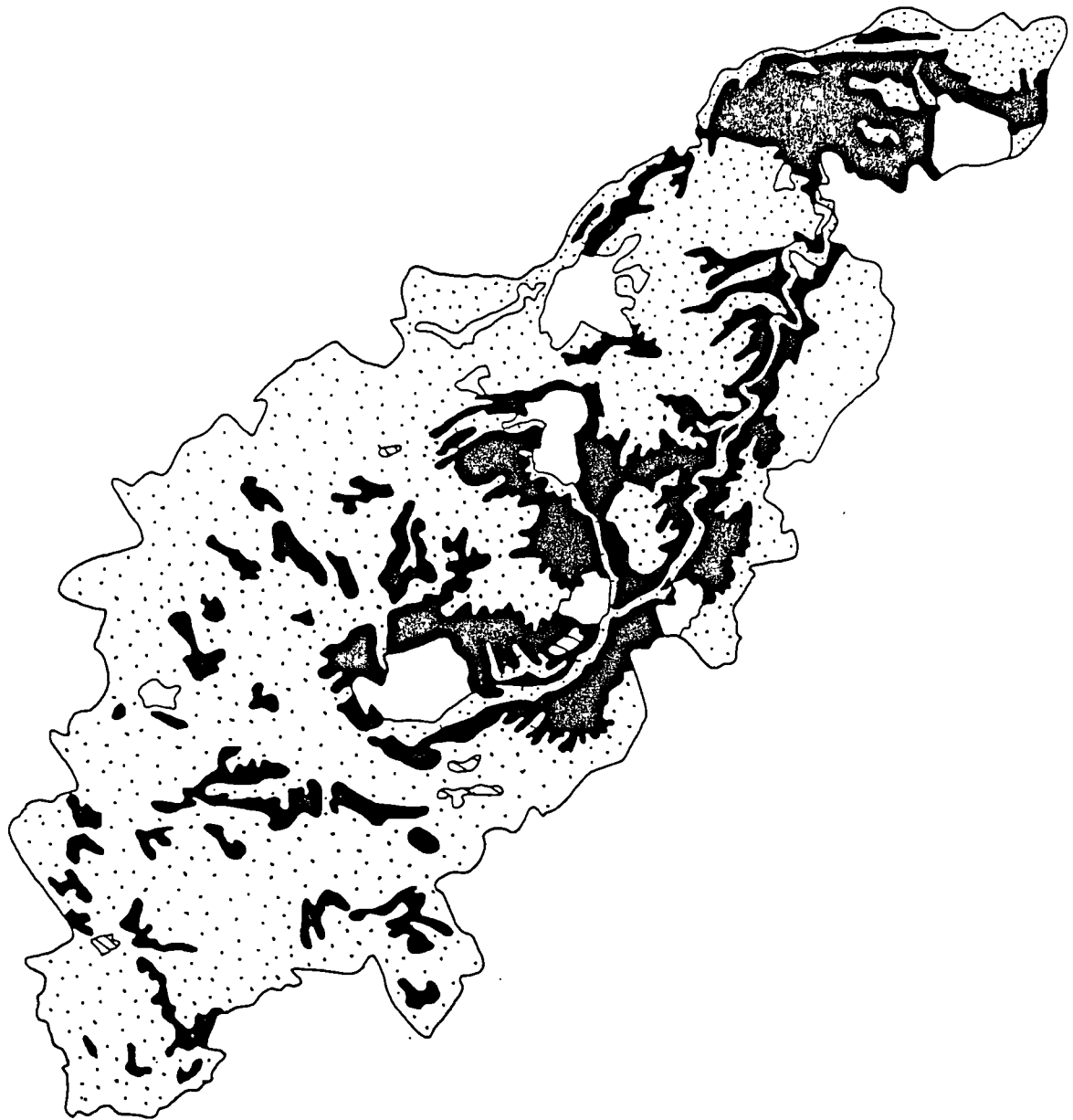

Figure 5.12 A generalised map of crop mark visibility in the study region. The map uses the levels of visibility listed in table 3.1. Black = level iv, white = level i)

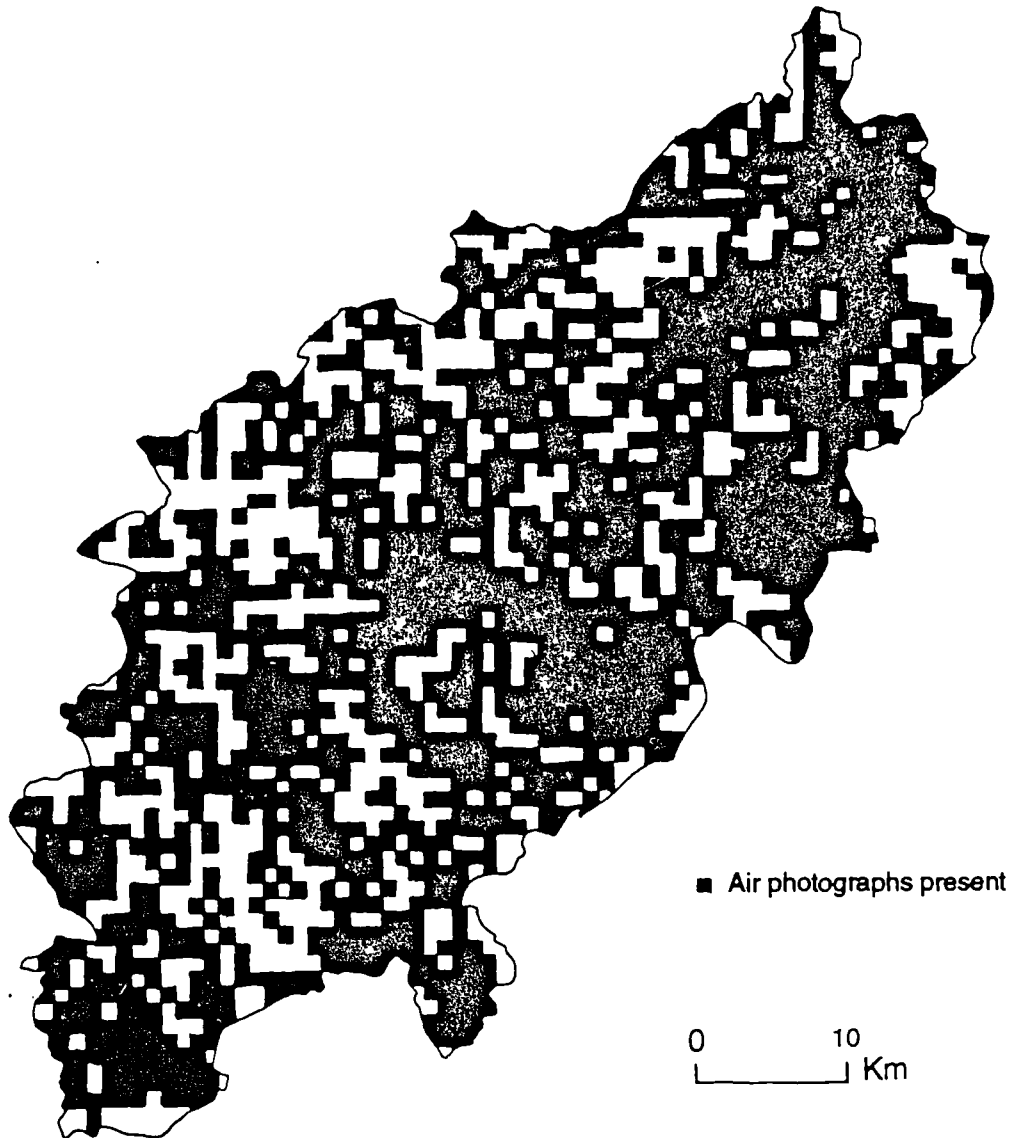

Figure 5.13 The distribution of air photographs by 1 kilometre square across Northamptonshire (data from RCHM Air Photographic Unit).

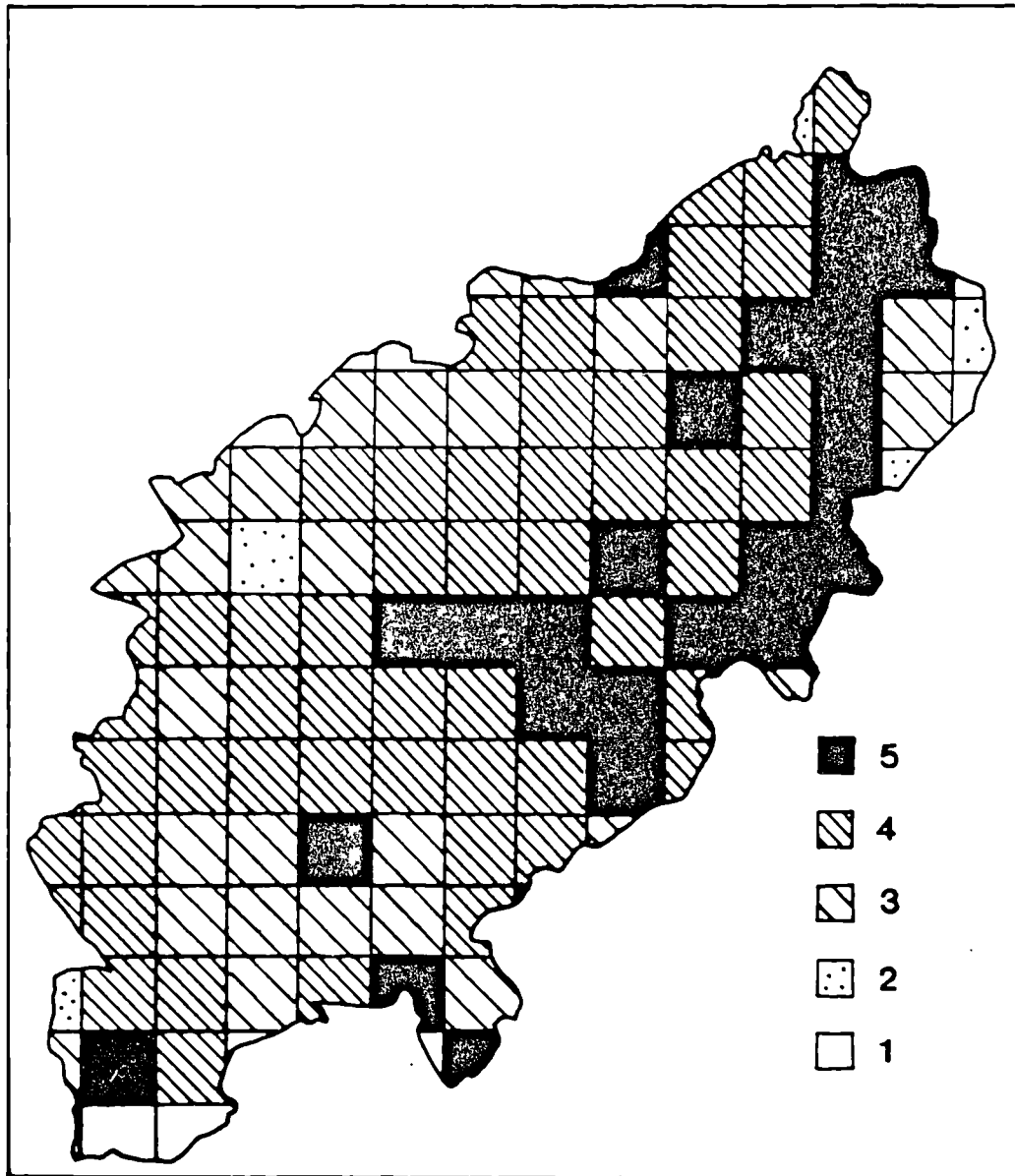

Figure 5.14 The density of air photographs by 10 kilometre square across Northamptonshire. The numbers are five density scores used by the RCHM, 5 being the highest concentrations of air photographs and 1 the lowest (data from RCHM Air Photographic Unit).

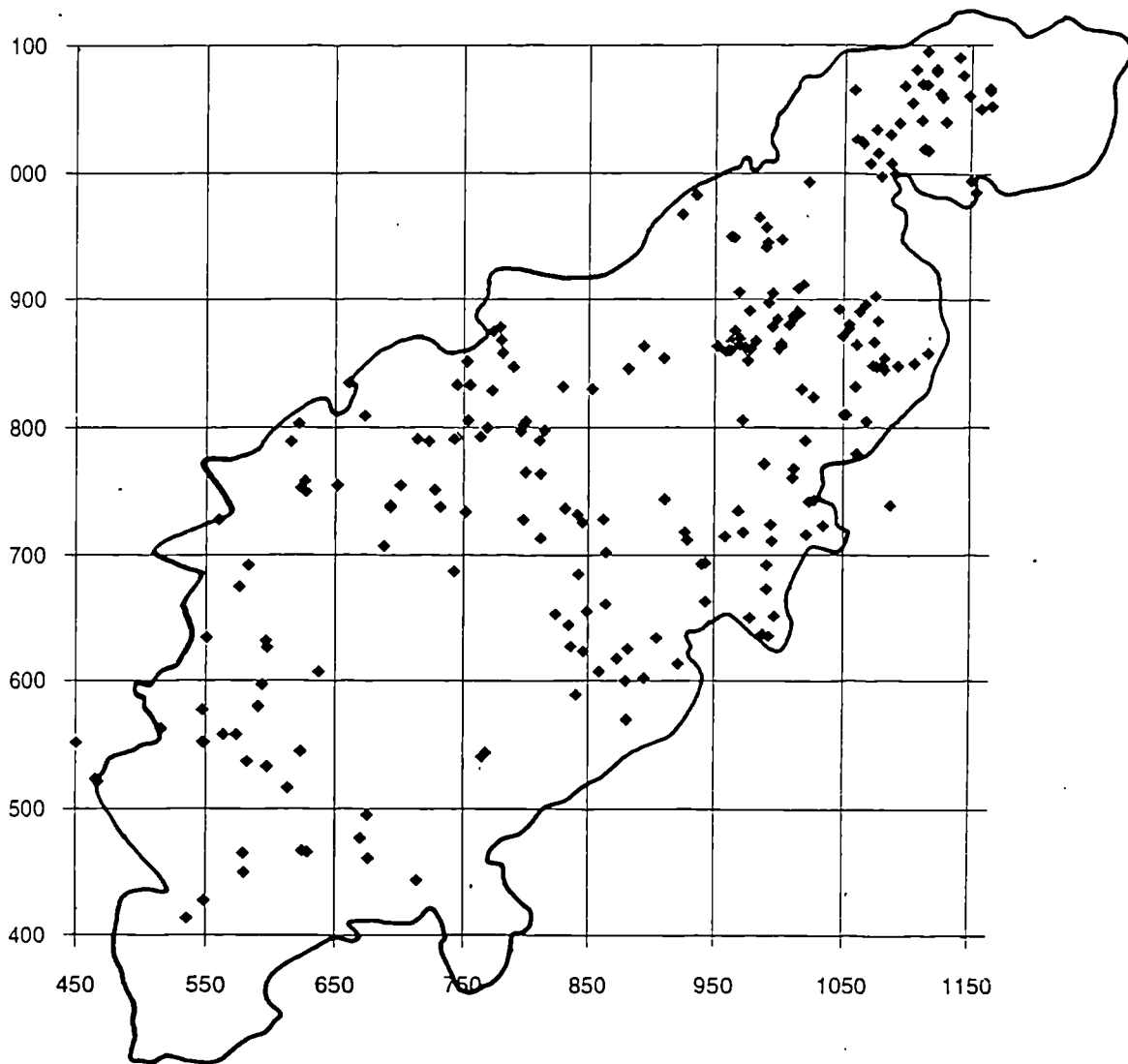

Figure 5.15 The distribution of iron age and Roman pottery scatters recorded by David Hall.

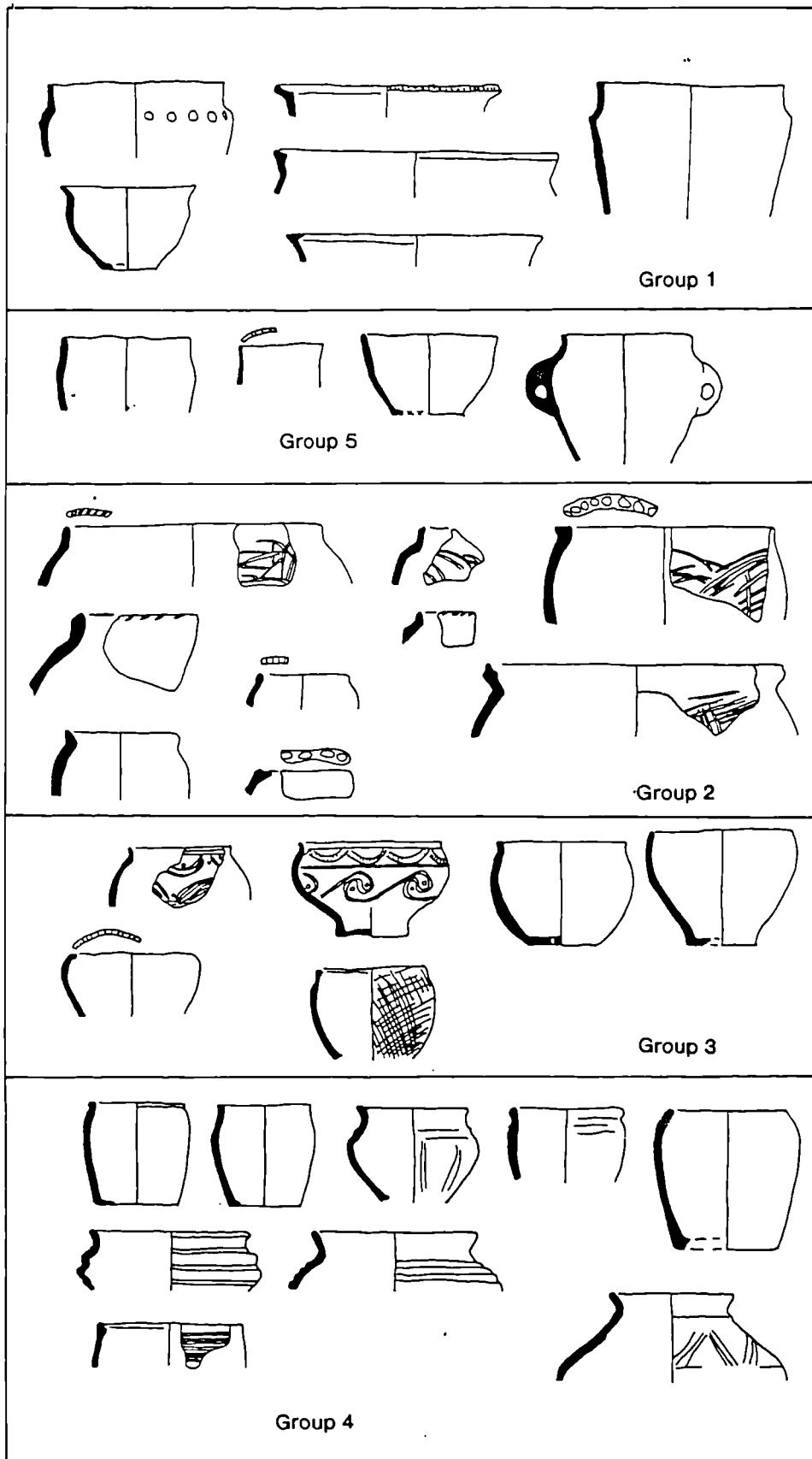

Figure 5.16 Examples of the main forms characterising iron age pottery groups 1 to 5.

a)	<p>Group 1</p> <p>Fengate f488</p> <p>Gt Oakley f28</p> <p>Gretton A1</p> <p>Gretton A2</p> <p>Fengate f1551</p> <p>Fengate f6</p> <p>Gretton B1</p> <p>Gretton B2</p> <p>Group 5</p> <p>Gt. Oakley f9</p> <p>Gt. Oakley f28</p> <p>Gretton A1</p> <p>Gretton A2</p> <p>Pennyland 1</p> <p>Hartigans 1</p> <p>Fengate f3</p> <p>Fengate f6</p> <p>Pennyland 2</p> <p>Gretton B1</p> <p>Gretton B2</p> <p>Group 2</p> <p>Fengate f3</p>	<p>b)</p> <p>Group 1</p> <p>Bancroft 1</p> <p>Bancroft 2</p> <p>Group 5</p> <p>Hunsbury 2</p> <p>Hunsbury 1</p> <p>Hunsbury 3</p> <p>Twywell</p> <p>Hartigans 2</p> <p>Group 2</p> <p>Gretton B1</p> <p>Twywell</p> <p>Gretton B2</p> <p>Ringstead</p> <p>Weekley 1</p> <p>Weekley 2</p> <p>Weekley 3</p> <p>Weekley 4</p> <p>Weekley 5</p> <p>Group 3</p> <p>Weekley 1</p> <p>Weekley 2</p> <p>Odell 1</p> <p>Weekley 3</p> <p>Odell 2</p> <p>Weekley 4</p> <p>Odell 3</p> <p>Weekley 5</p> <p>Group4</p> <p>Odell 1</p> <p>Odell 2</p> <p>Odell 3</p>
-----------	---	---

Figure 5.17 Calibrated dates for each pottery group found in the same stratigraphic context (a), and found within the same phase or phases from a site (b). Calibrated dates and references are listed in Appendix 3.

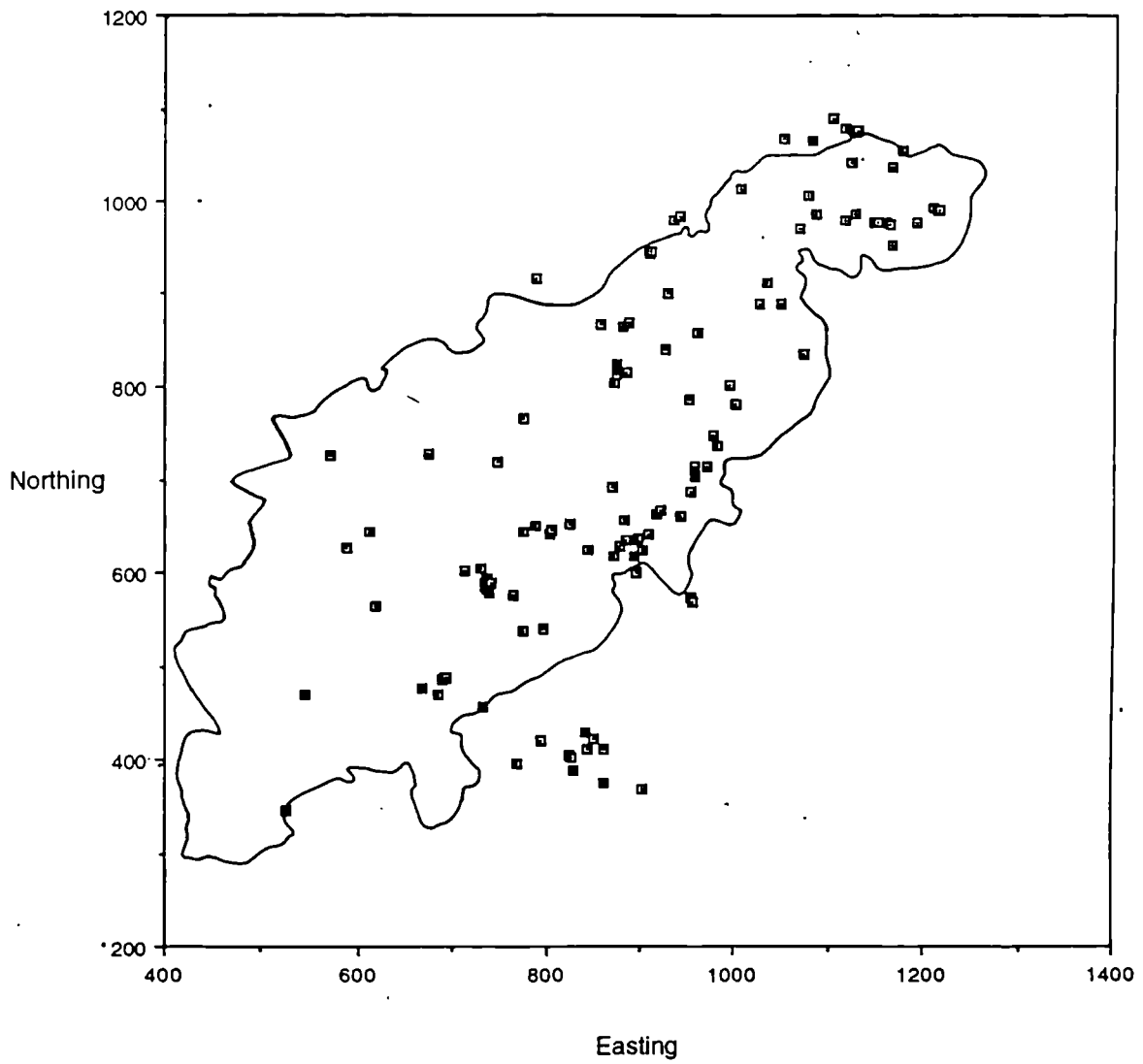

Figure 5.18 Distribution map of the excavated and surveyed sites listed in appendix 1 and used for the analyses in chapter 6.

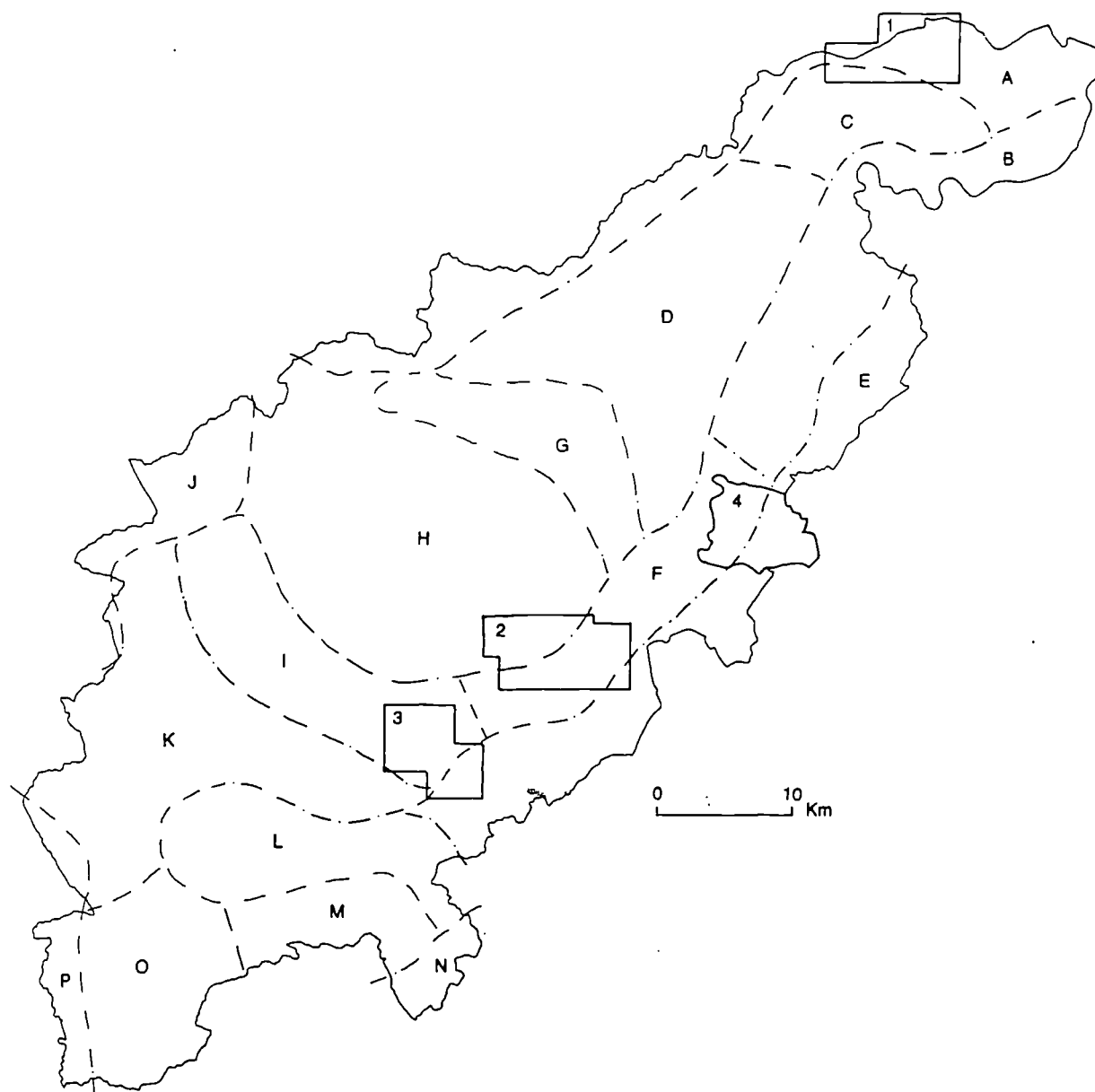

Figure 6.1 Map of the study region showing the main topographical and pedological zones (A-P), the location of the three study areas (1-3) and the Raunds Area Project (4). The main river valleys are the Welland (A), the lower Nene (B), the middle Nene (F), the upper Nene (I), the Avon (J), the Lse (G), the Tove (L), the Ouse (N), and the Cherwell (P). Deeply dissected high uplands over clays lie at D, K and H. Lightly dissected upland with boulder clays lie at E and M, and over limestone at C. O covers lightly dissected uplands over variable geology (data from Foard 1979).

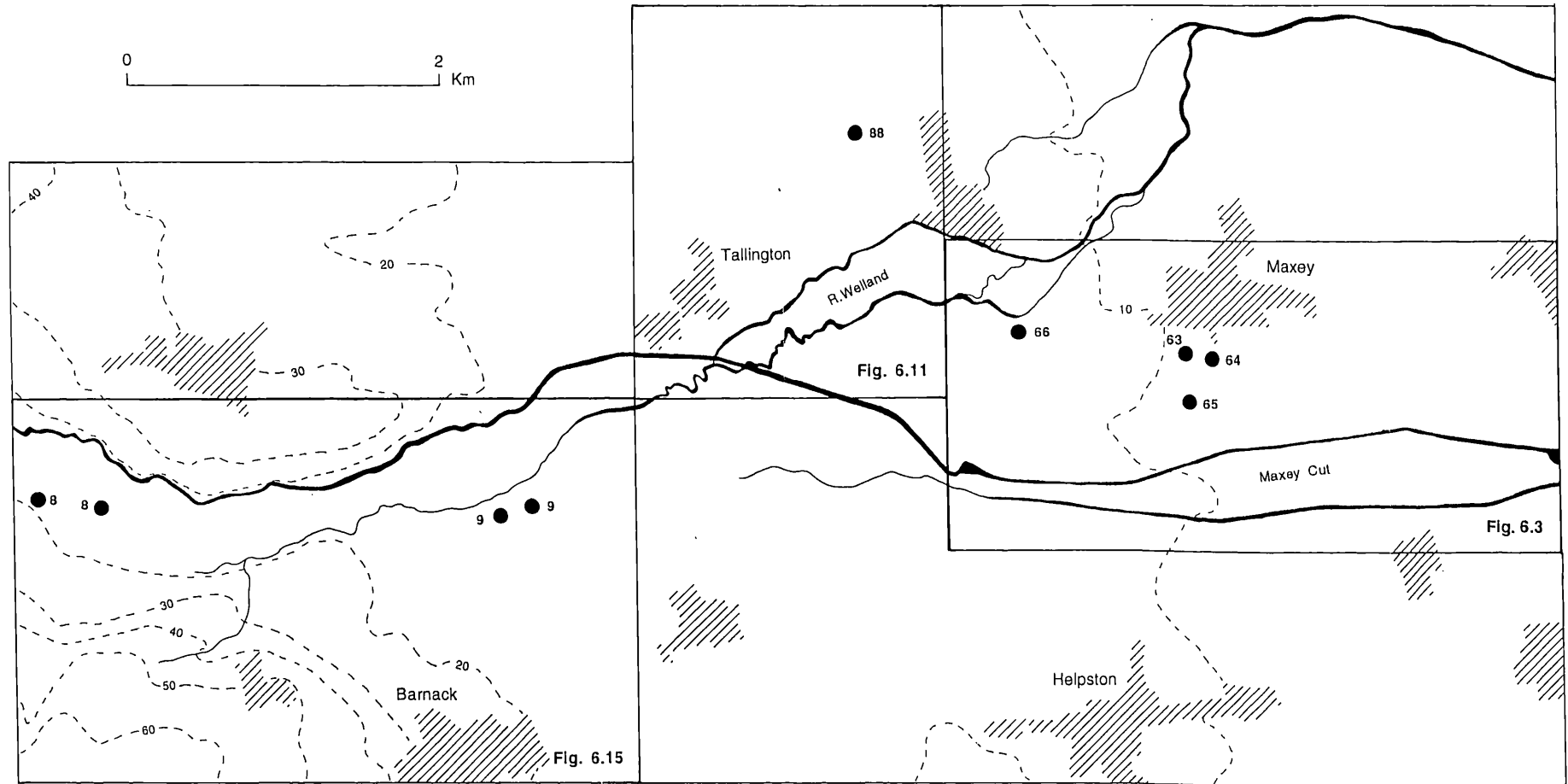

Figure 6.2 Location map of the Maxey/Barnack case study showing detailed study blocks

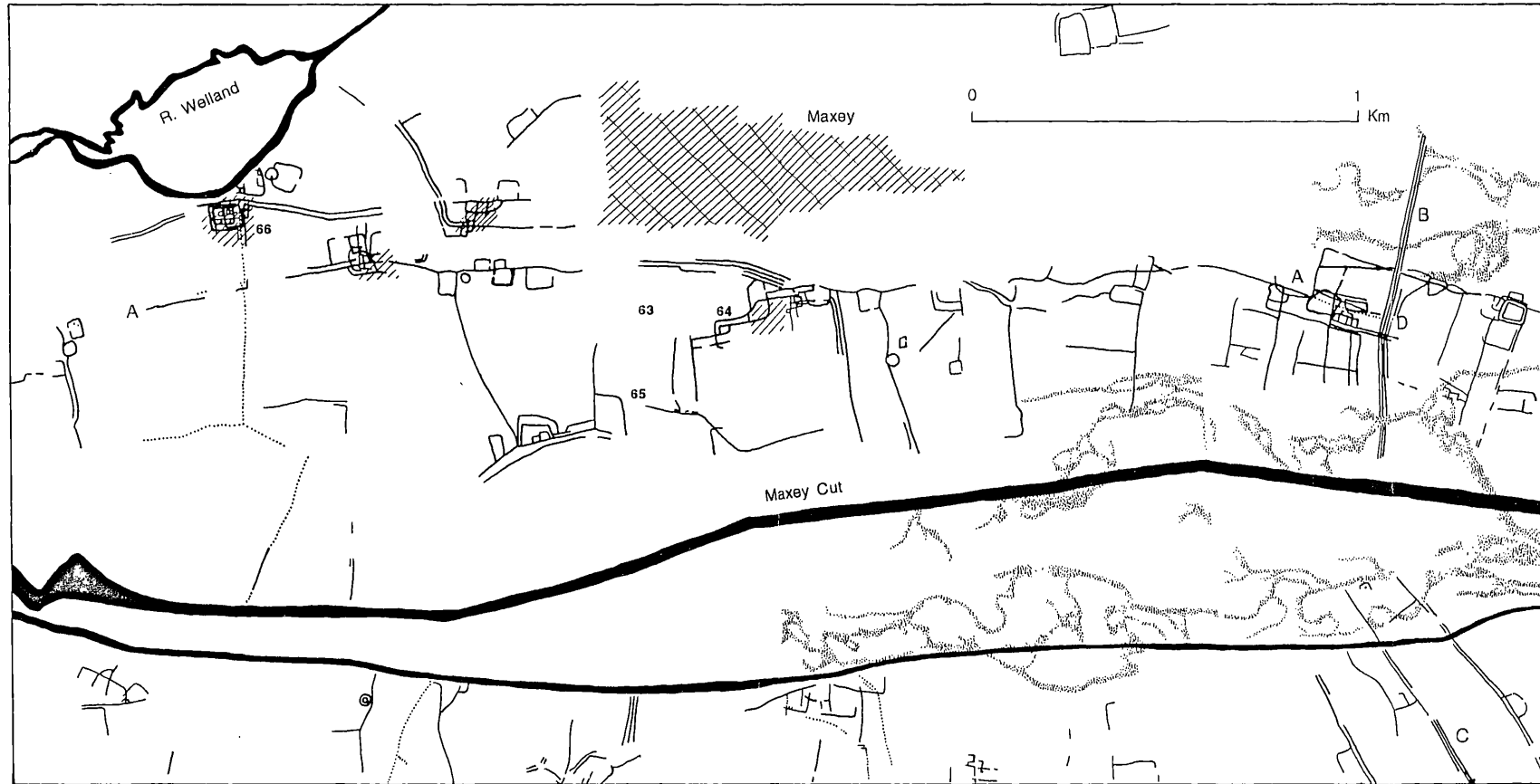
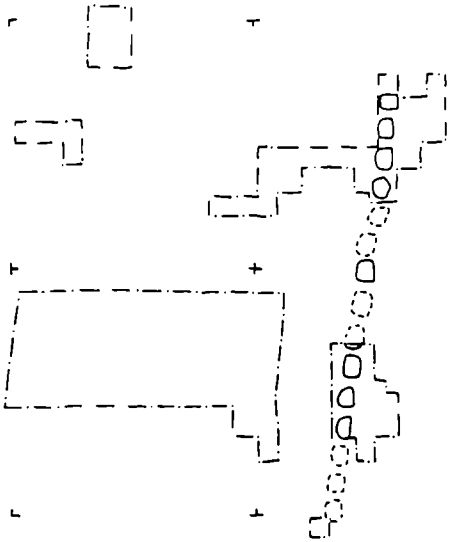
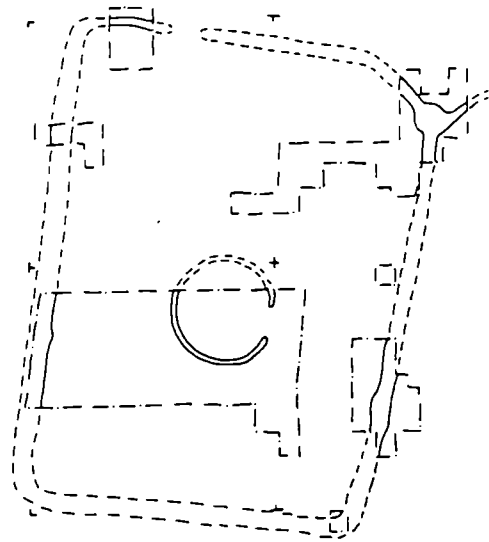

Figure 6.3 Crop mark, field walking and excavated evidence around Maxey

A Early-Mid Iron Age



B Late Iron Age



C Early Roman

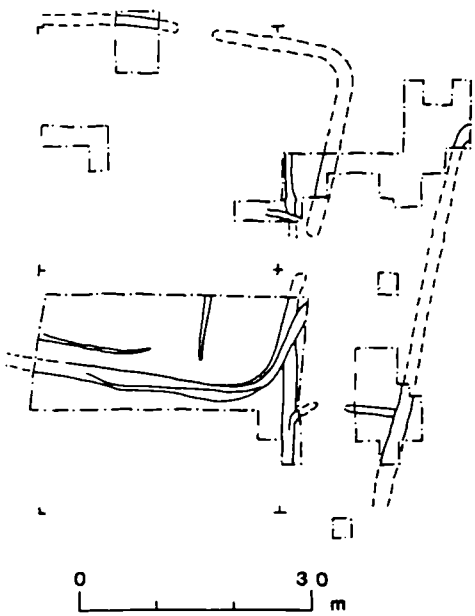

D Late Roman

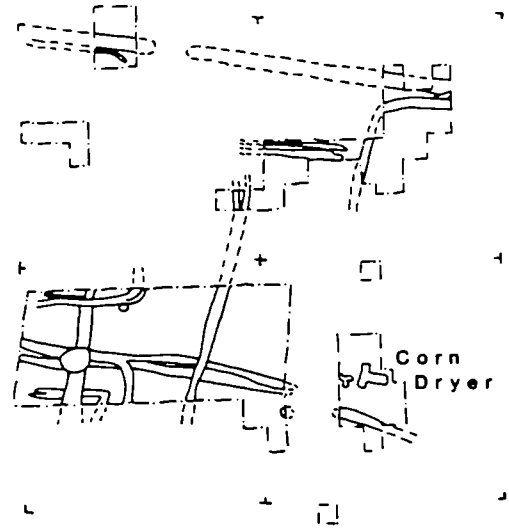

Figure 6.4 Phase plans of Maxey 66

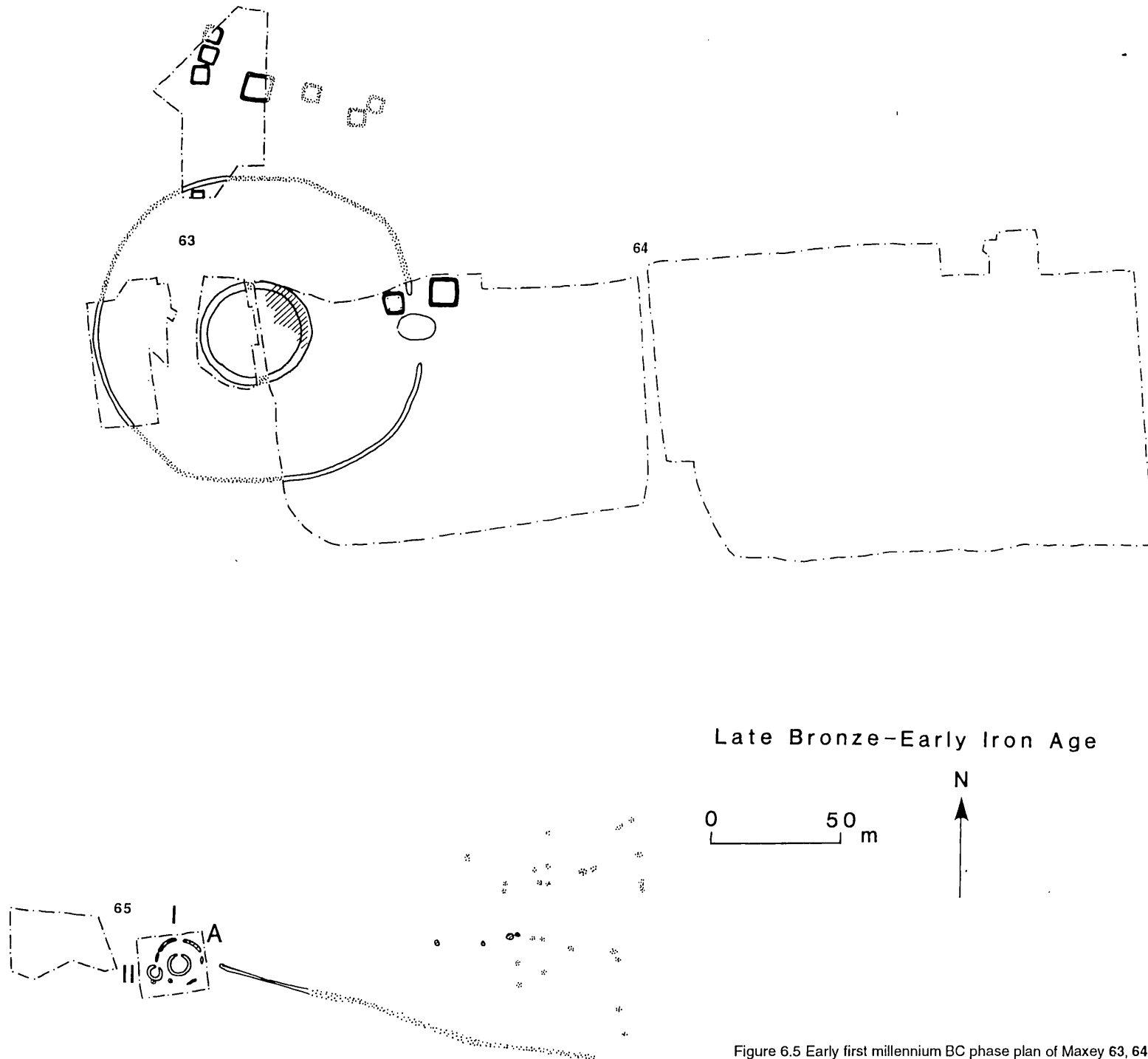
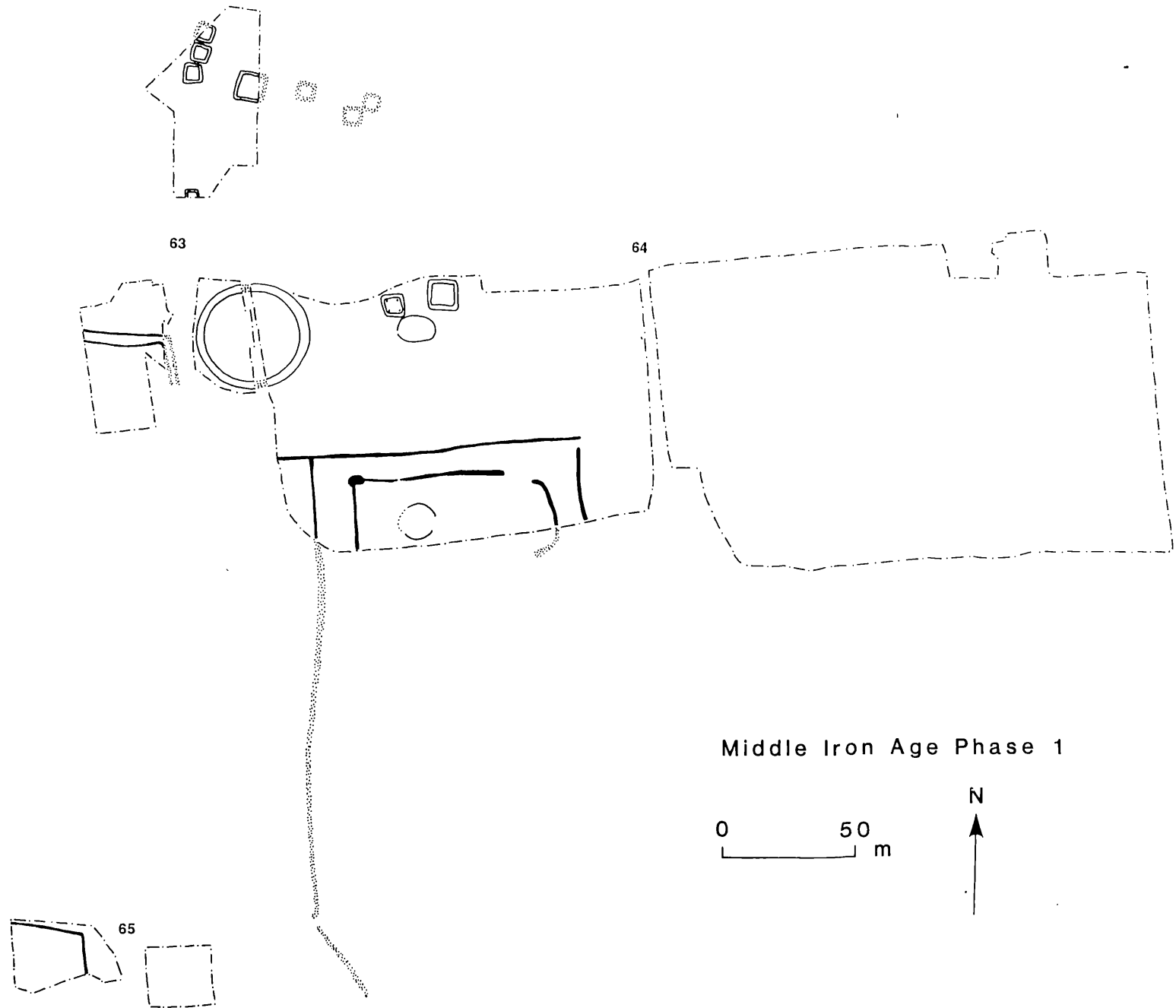

Figure 6.5 Early first millennium BC phase plan of Maxey 63, 64 and 65



Middle Iron Age Phase 1

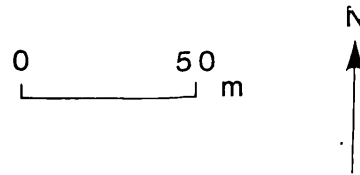

Figure 6.6 middle iron age phase 1 at Maxey 63, 64 and 65

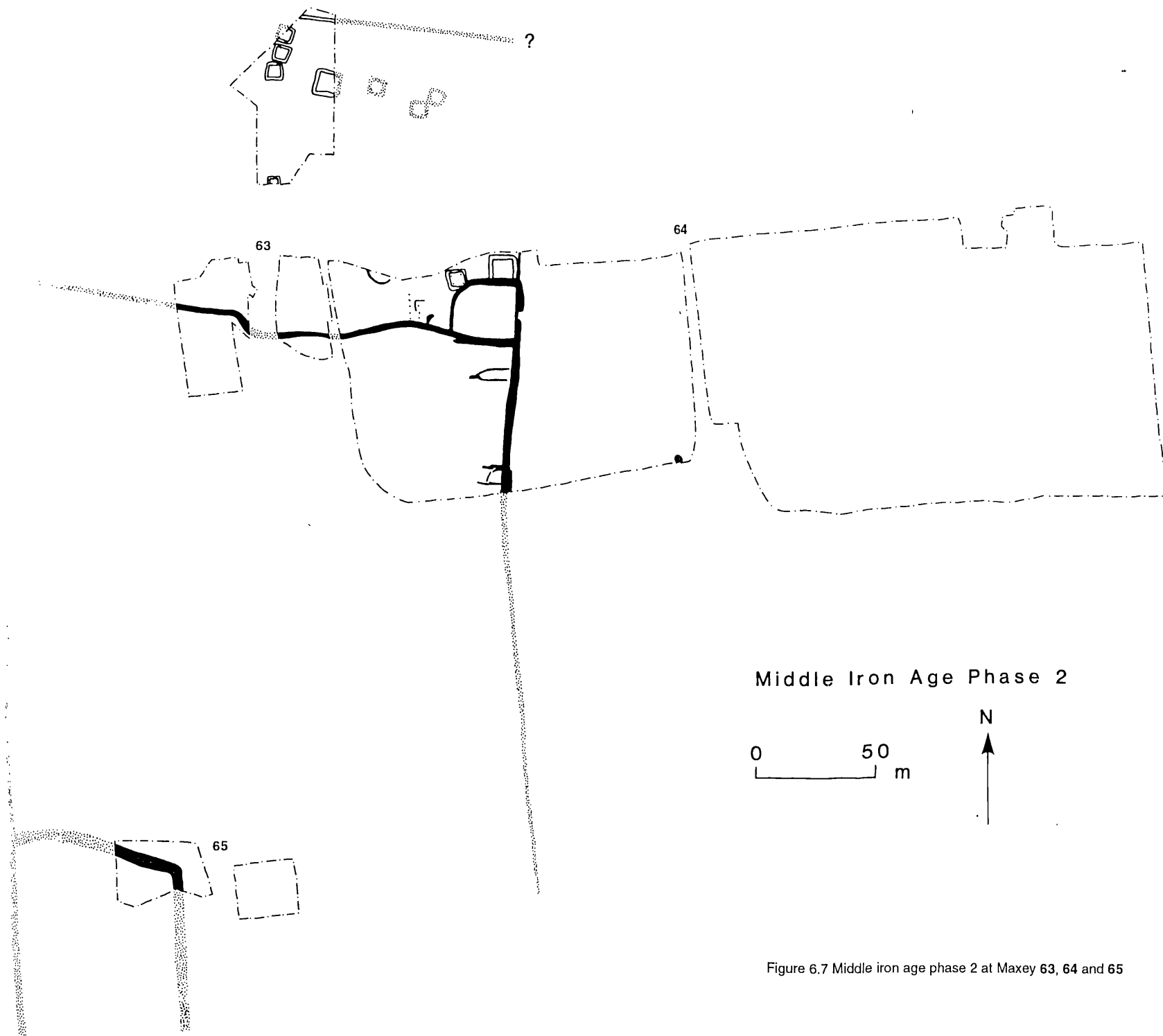

Figure 6.7 Middle iron age phase 2 at Maxey 63, 64 and 65

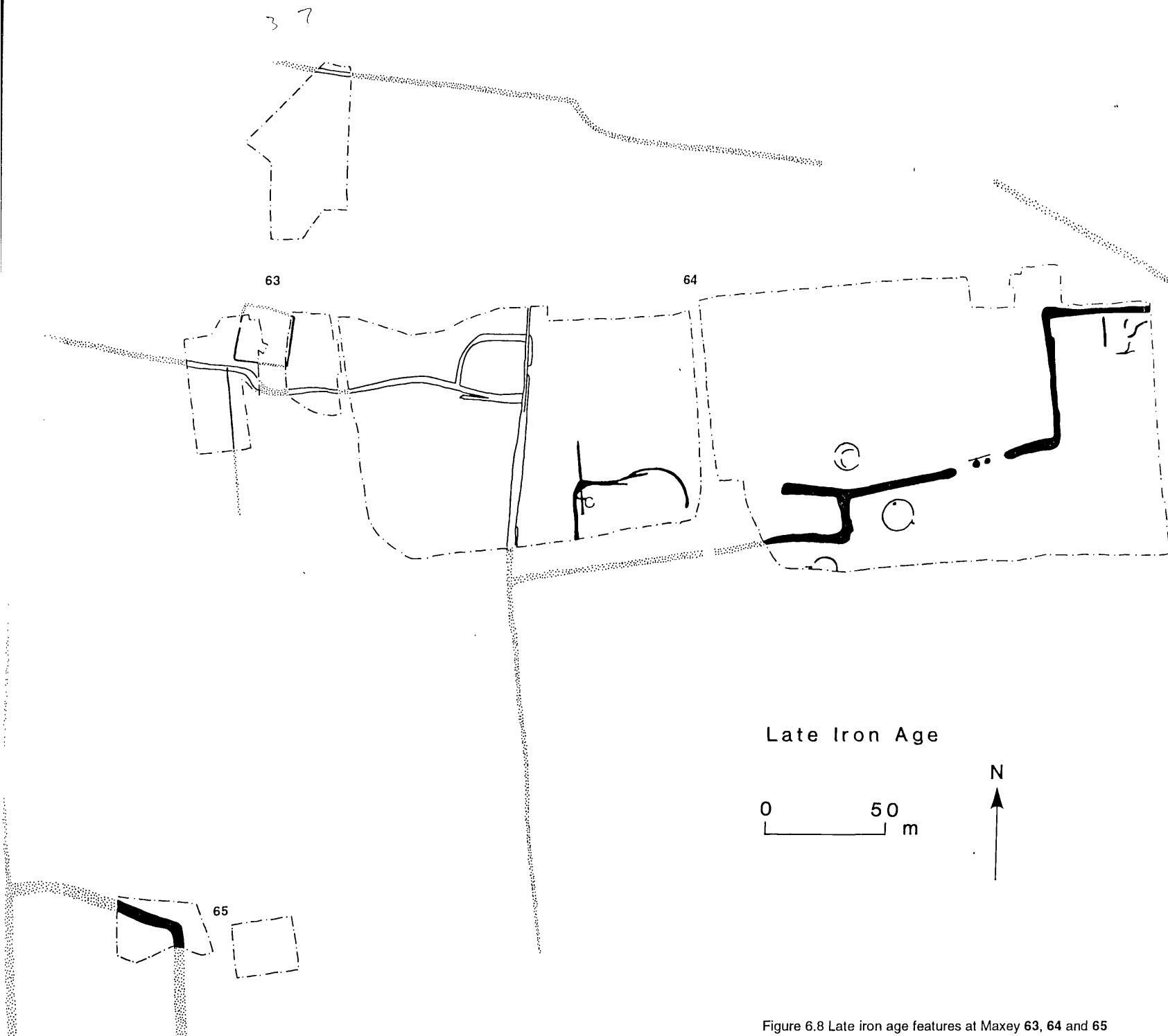
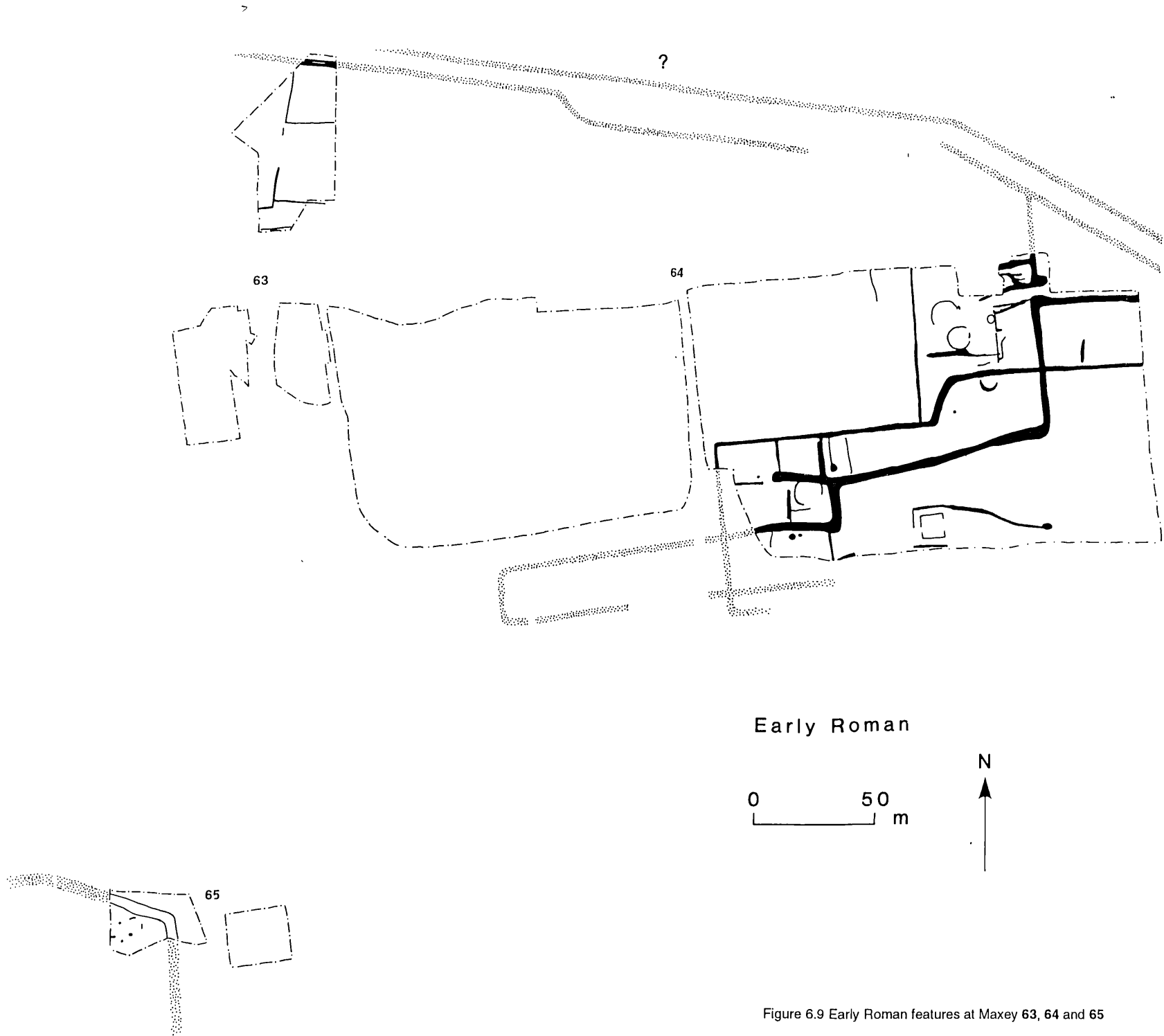

Figure 6.8 Late iron age features at Maxey 63, 64 and 65



Early Roman

0 50 m

N

Figure 6.9 Early Roman features at Maxey 63, 64 and 65

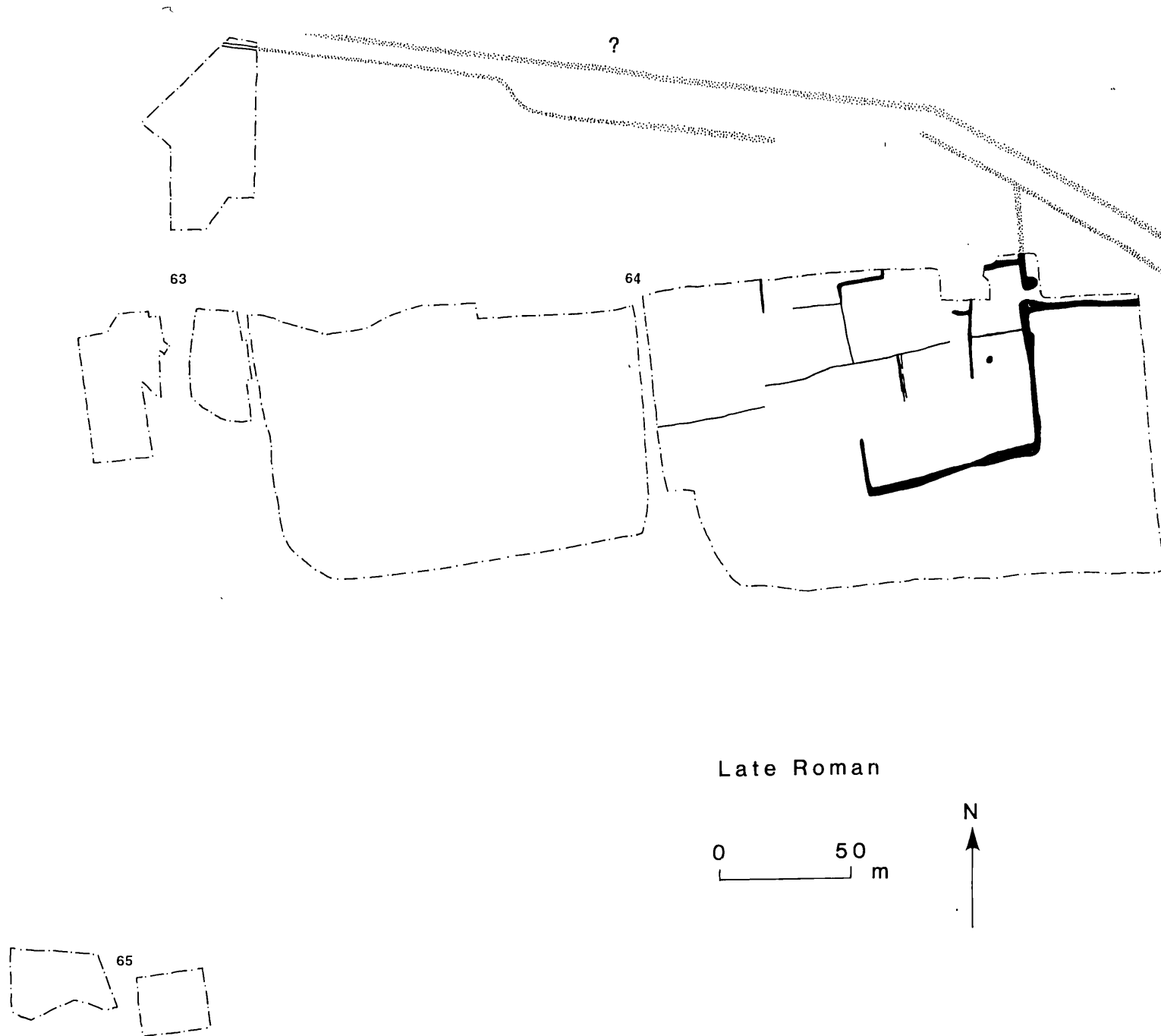

Figure 6.10 Later Roman features at Maxey 63, 64 and 65

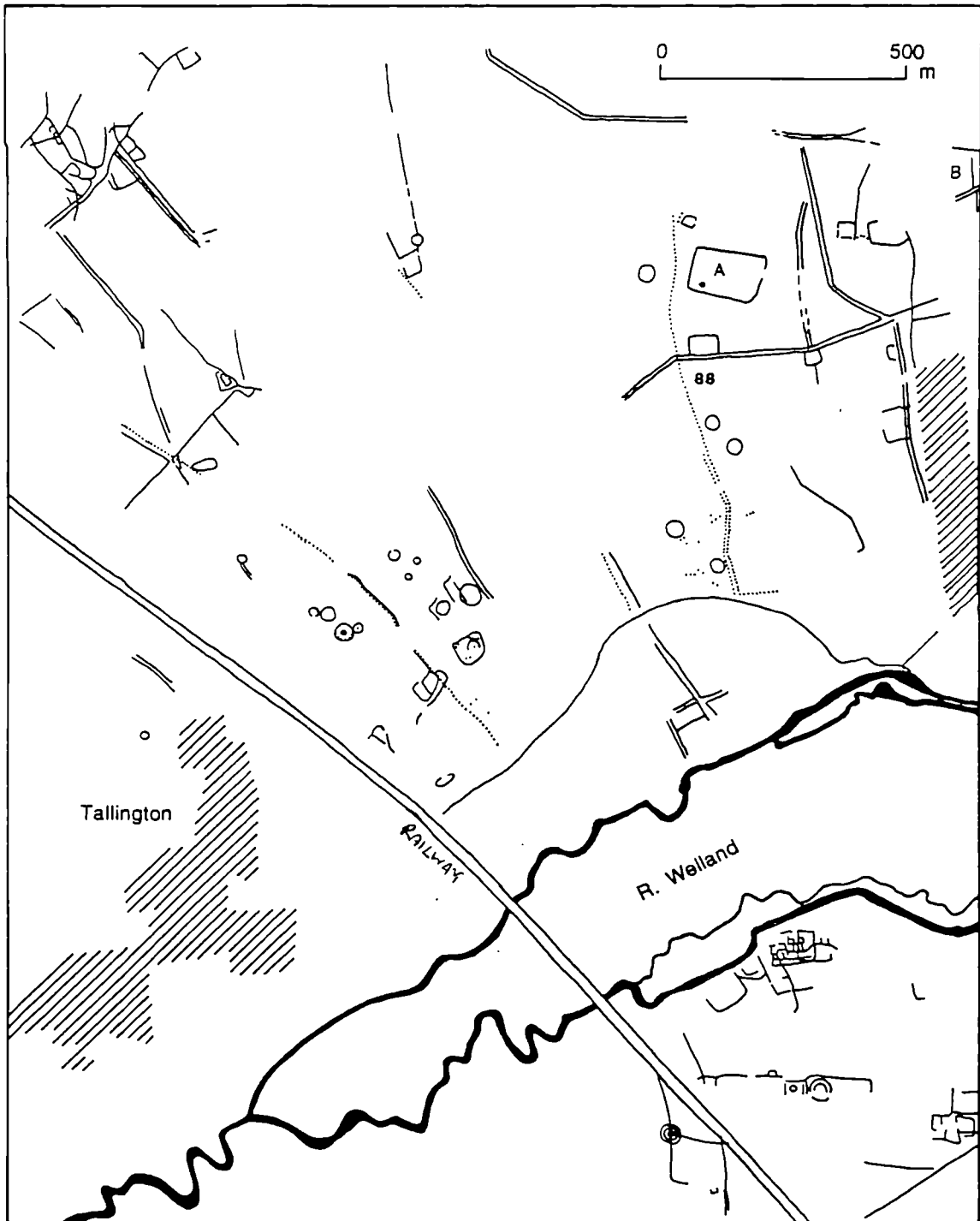
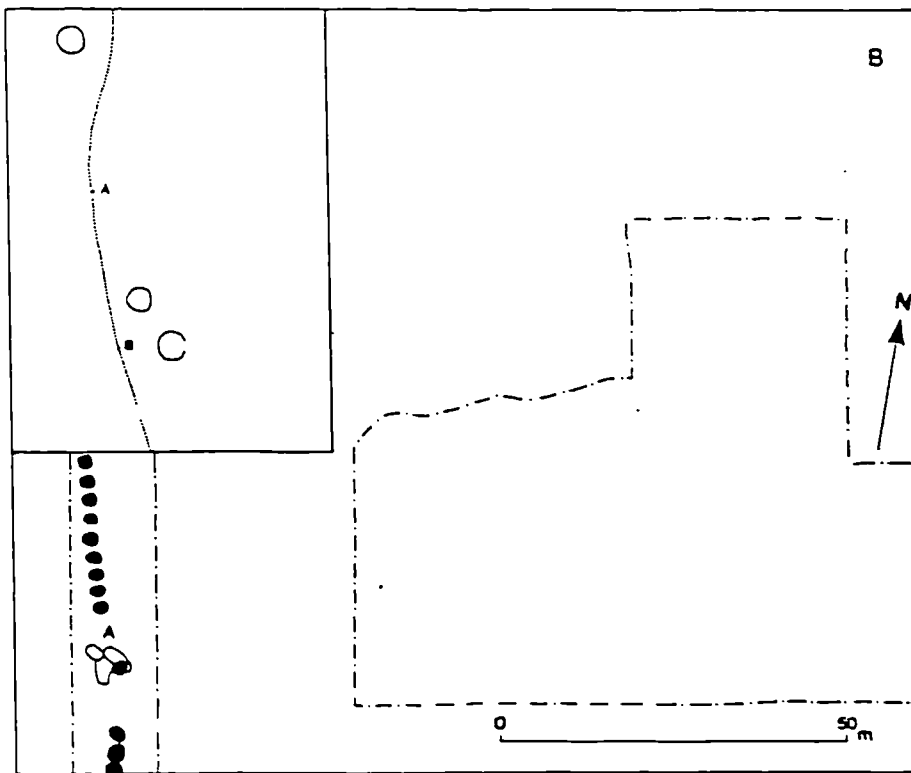
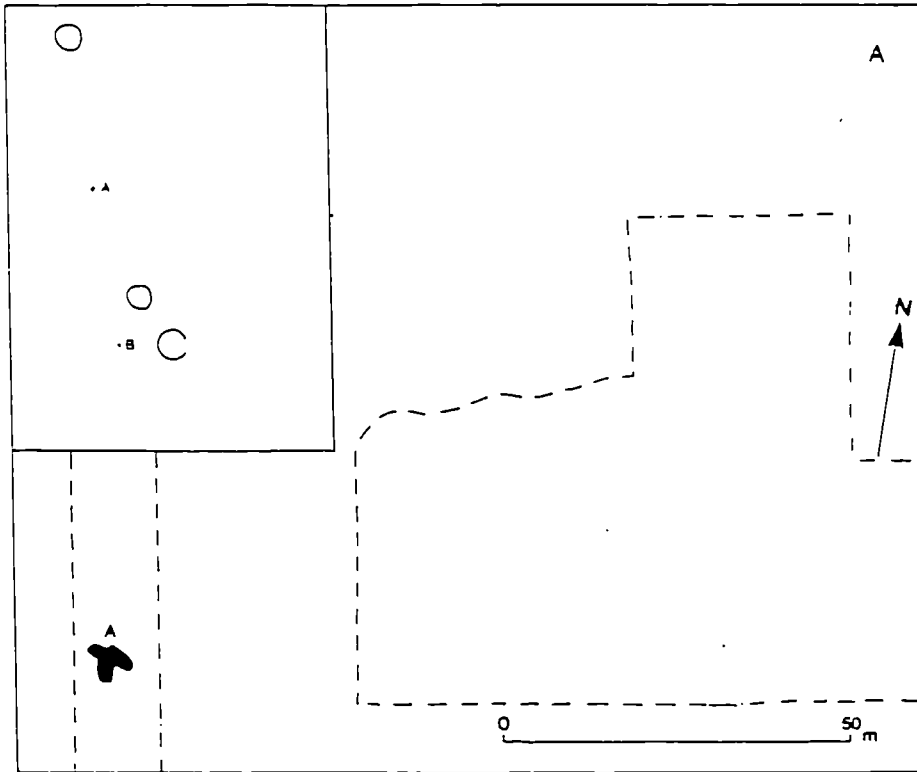
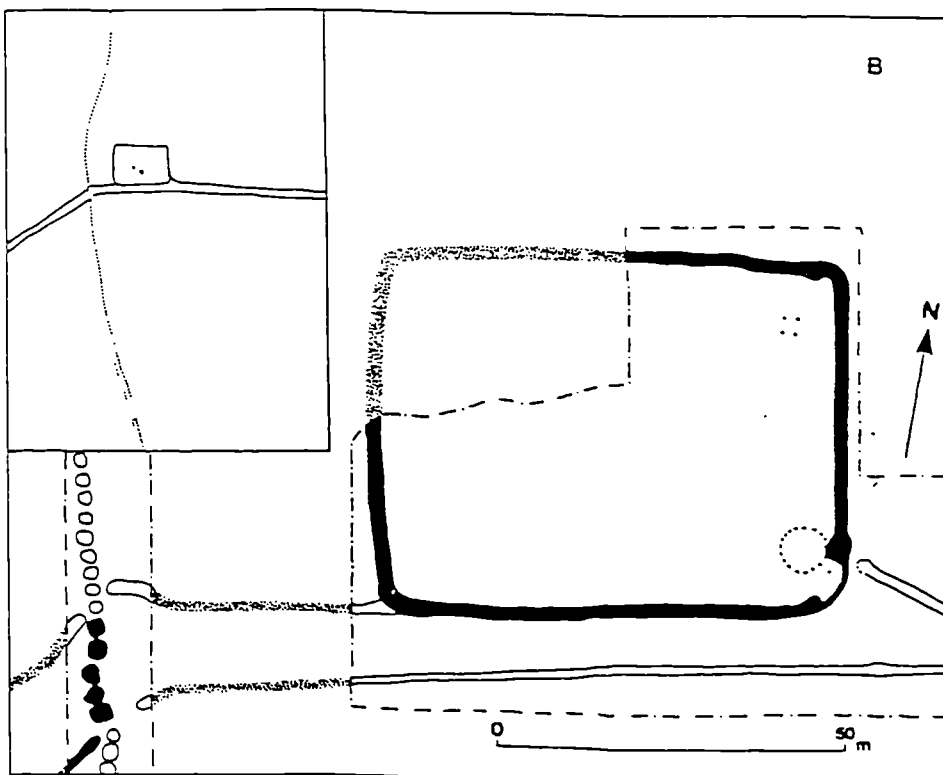
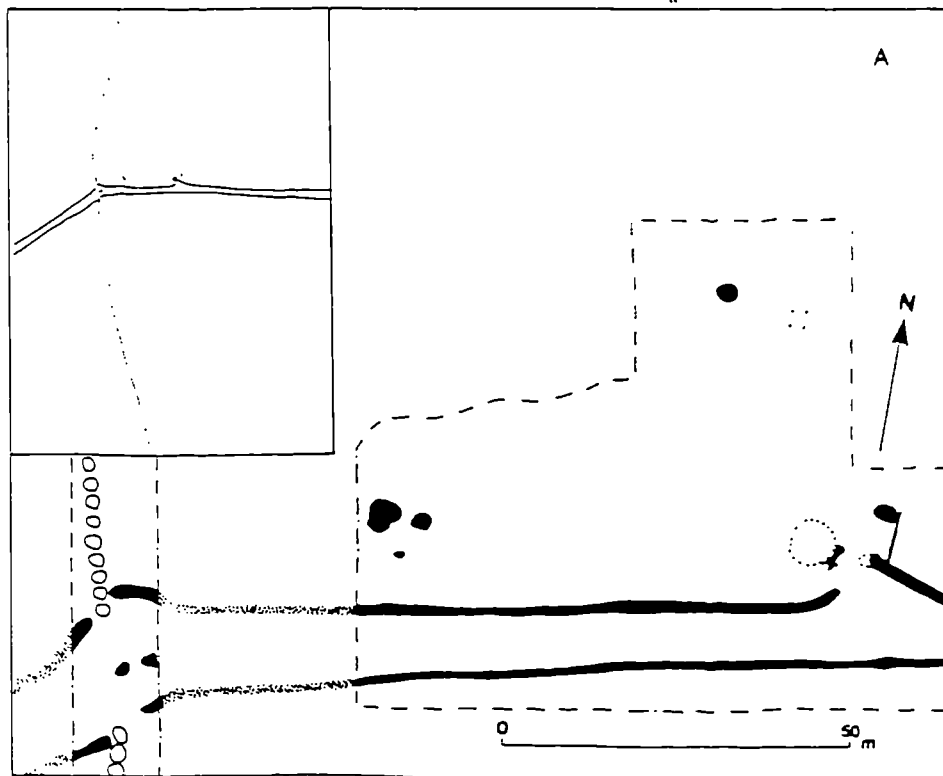

Figure 6.11 Crop mark and excavated evidence around Tallington



88
Figure 6.12 Tallington, early first millennium BC phases 1 and 2
A



38
Figure 6.13 Tallington, early first millennium BC phase 3 and 4
A

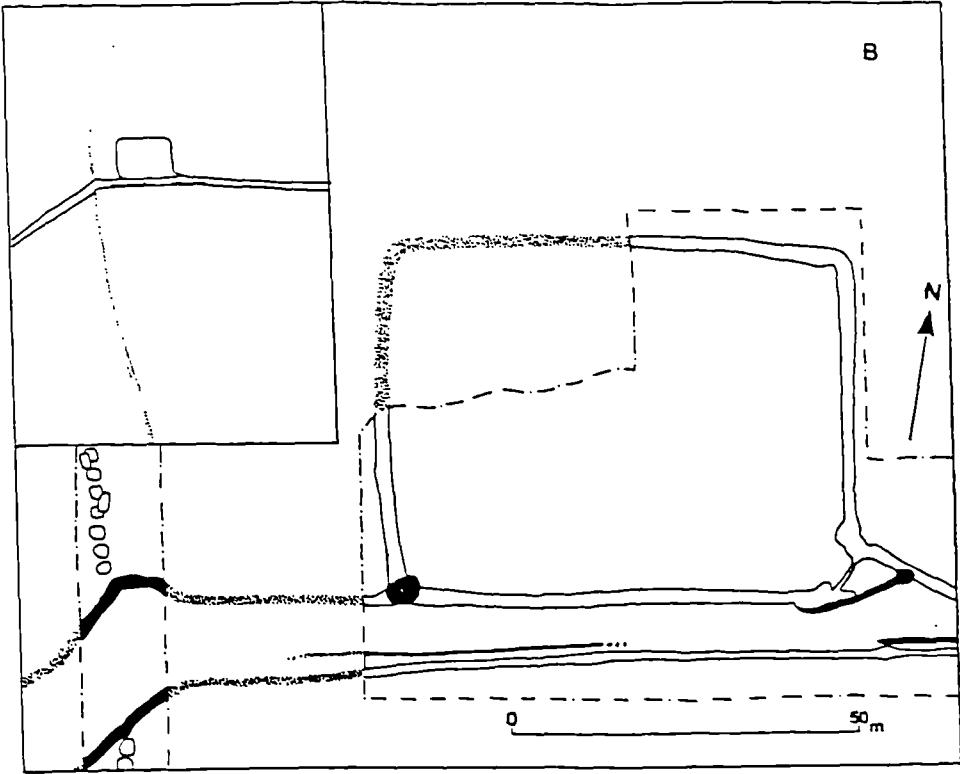
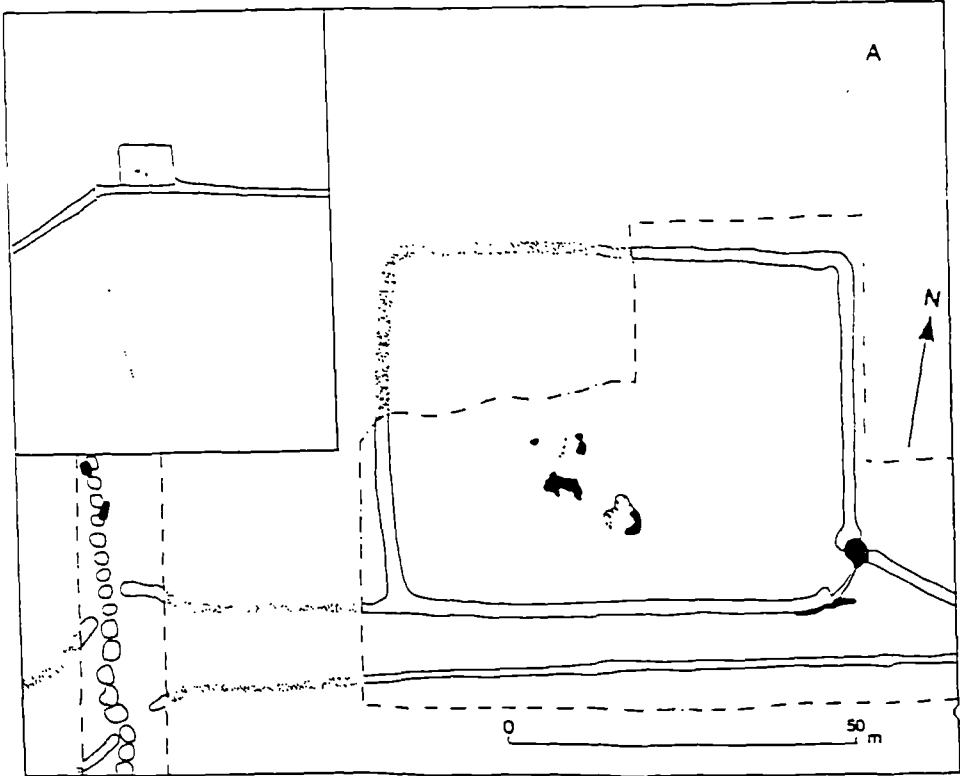

Figure 6.14 Tallington, middle and late iron age features

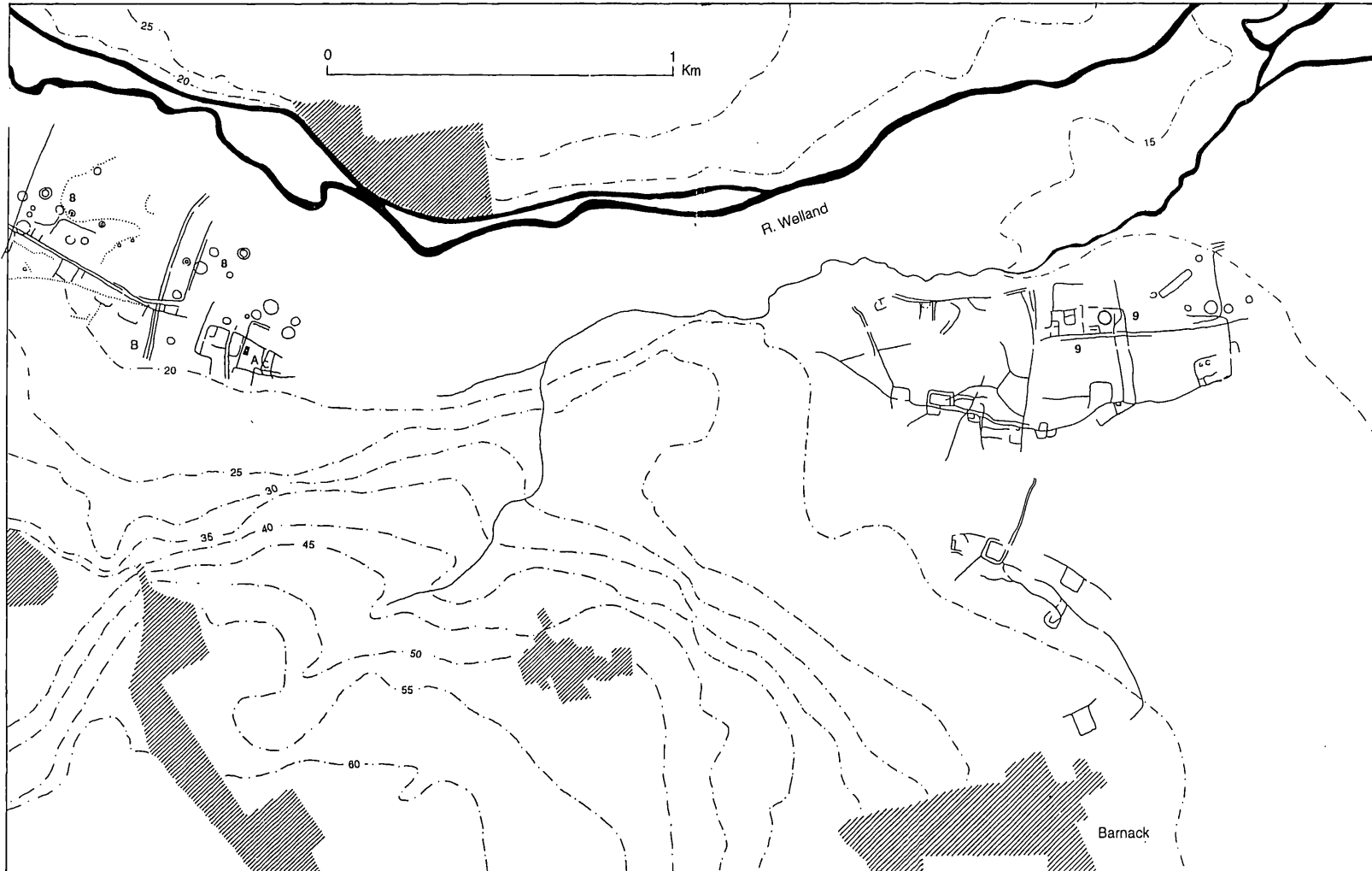

Figure 6.15 Crop marks and excavated evidence around Barnack

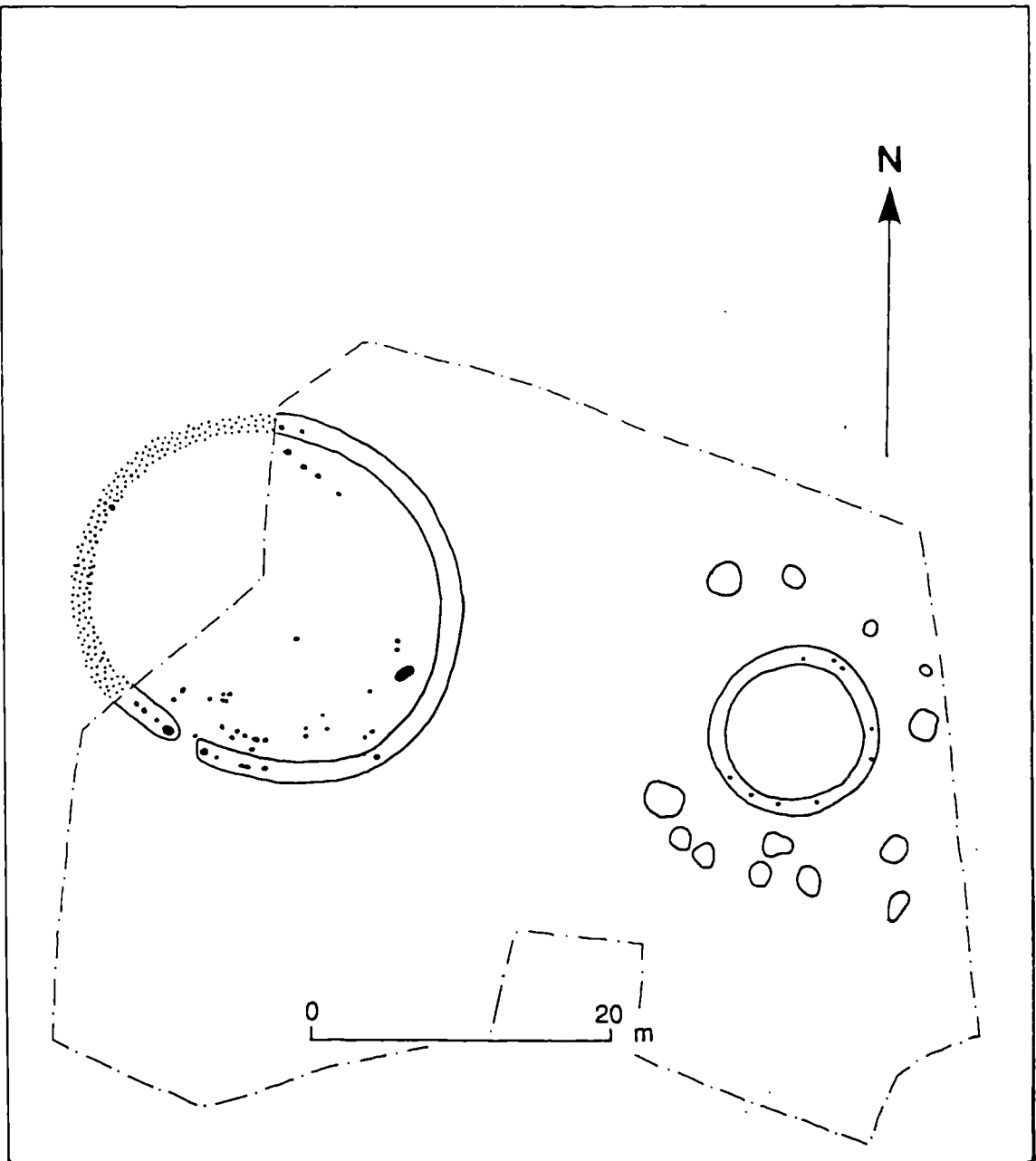

Figure 6.16 Phase 1 features from Pryor and O'Neill's excavations at Barnack 8

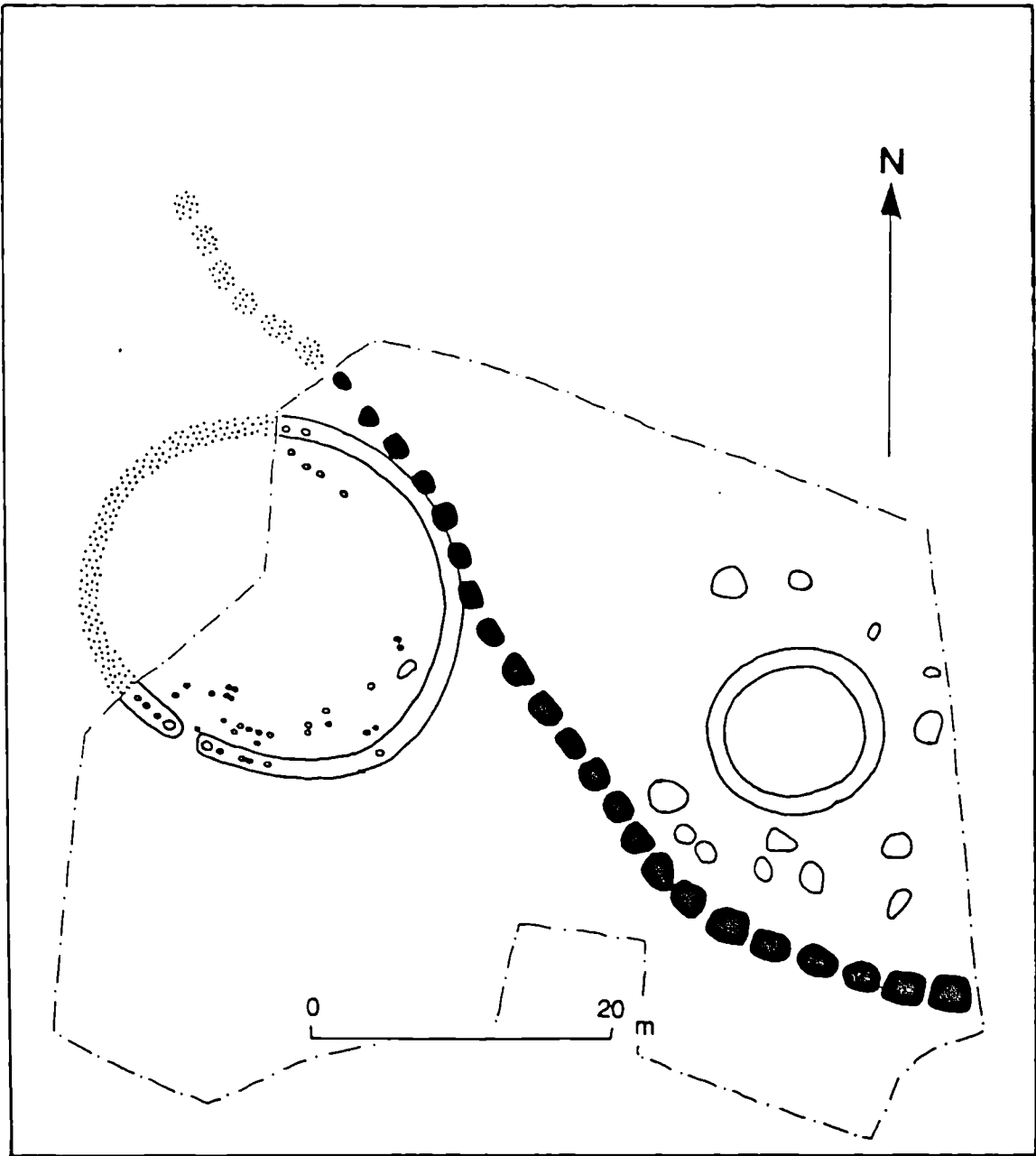

Figure 6.17 Phase 2 features from Pryor and O'Neill's excavations at Barnack 8

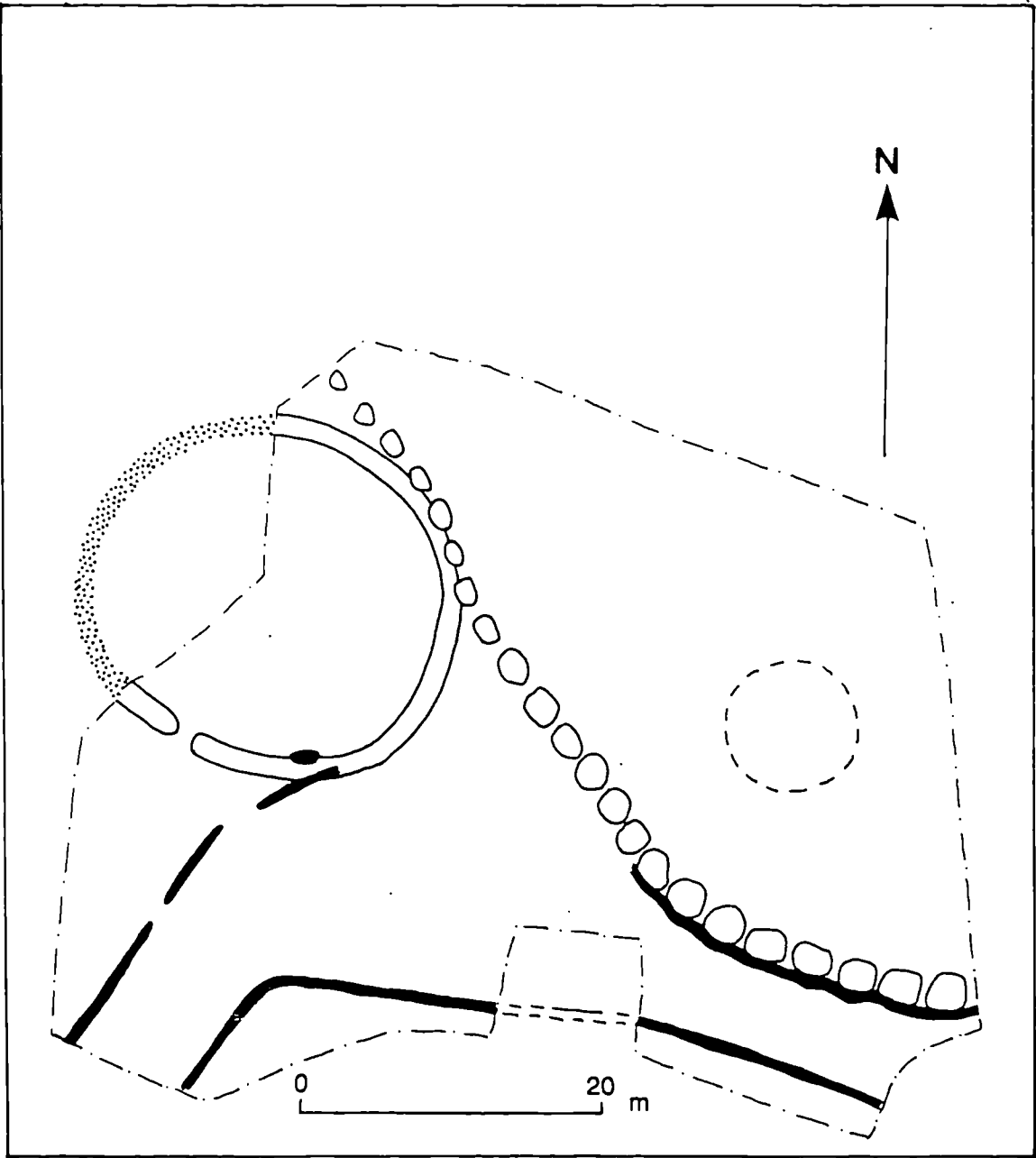

Figure 6.18 Phase 3 features from Pryor and O'Neill's excavations at Barnack 8



Figure 6.19 A) Middle and B) Late iron age features at Barnack 9

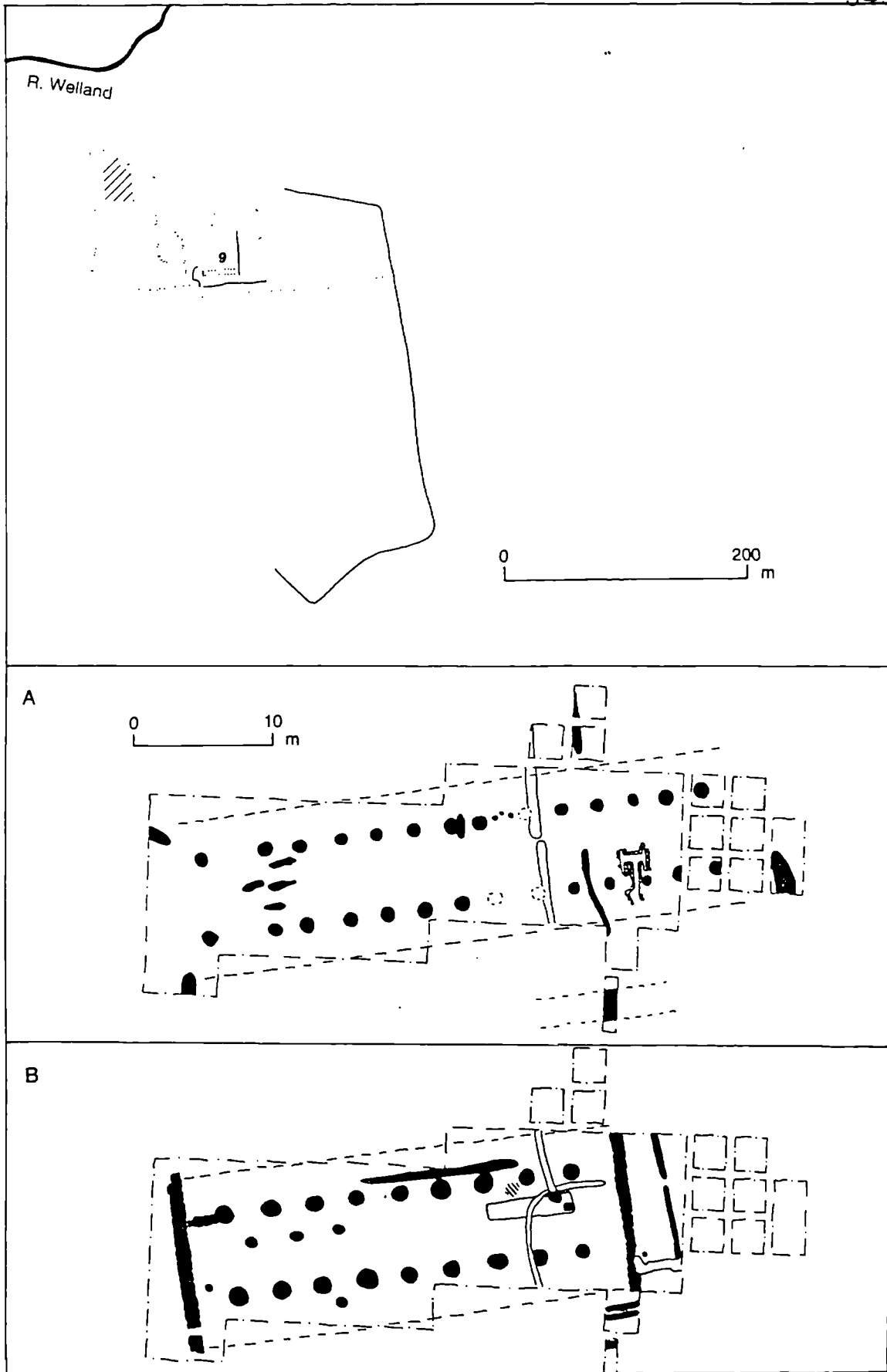

Figure 6.20 Roman features at Barnack 9

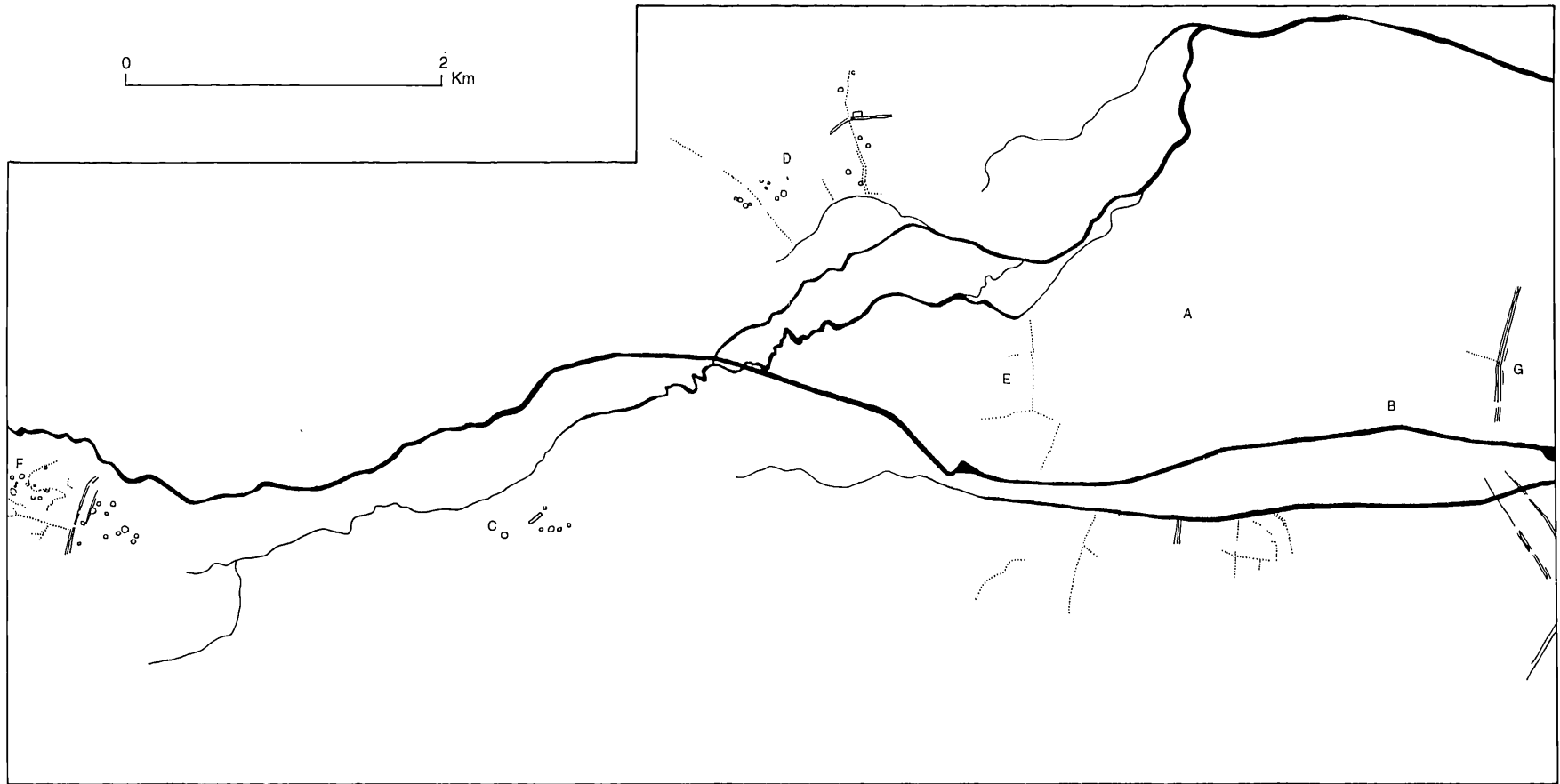

Figure 6.21 An interpretive map of earlier first millennium BC features across the Maxey/Barnack case study

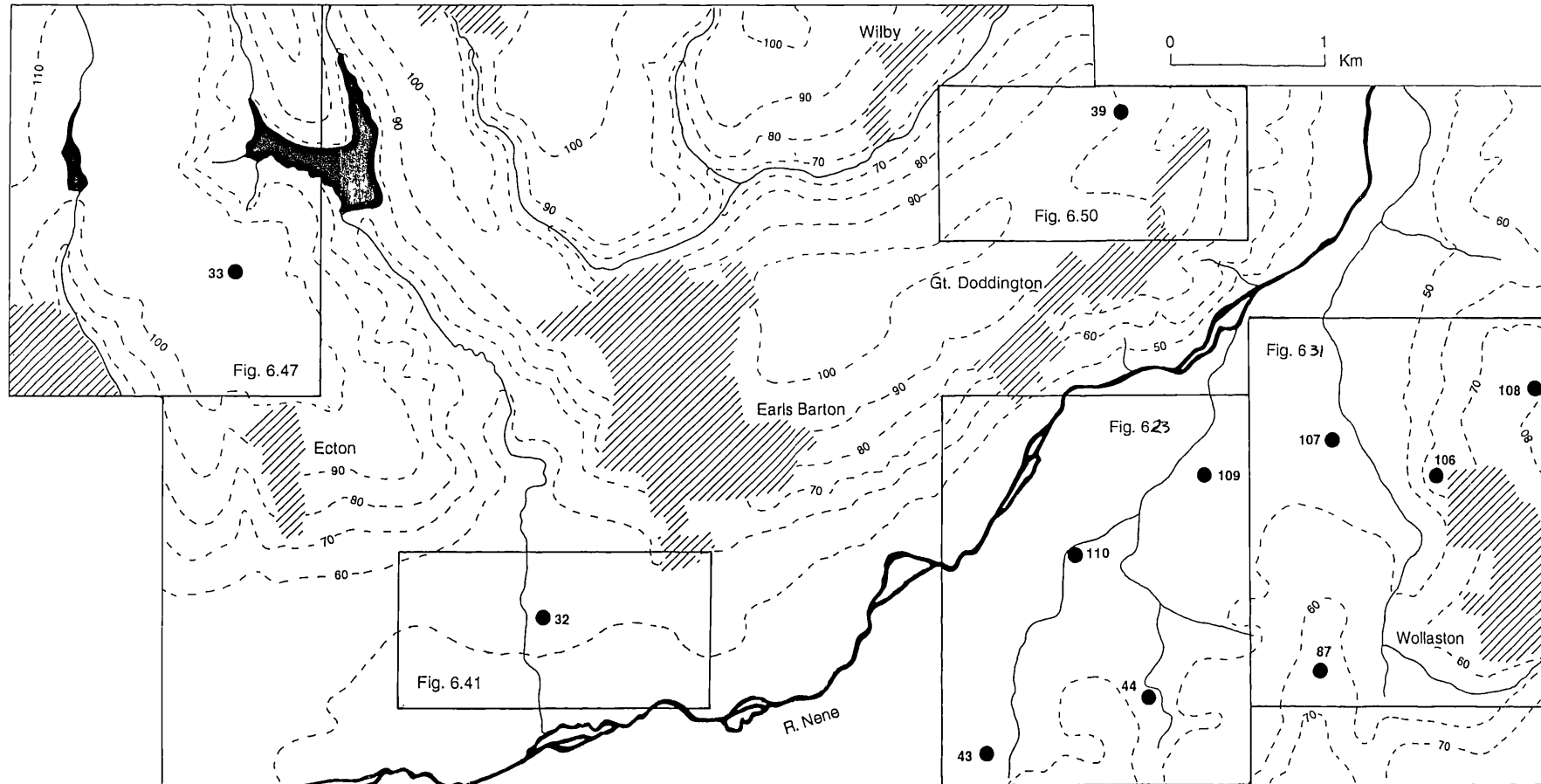
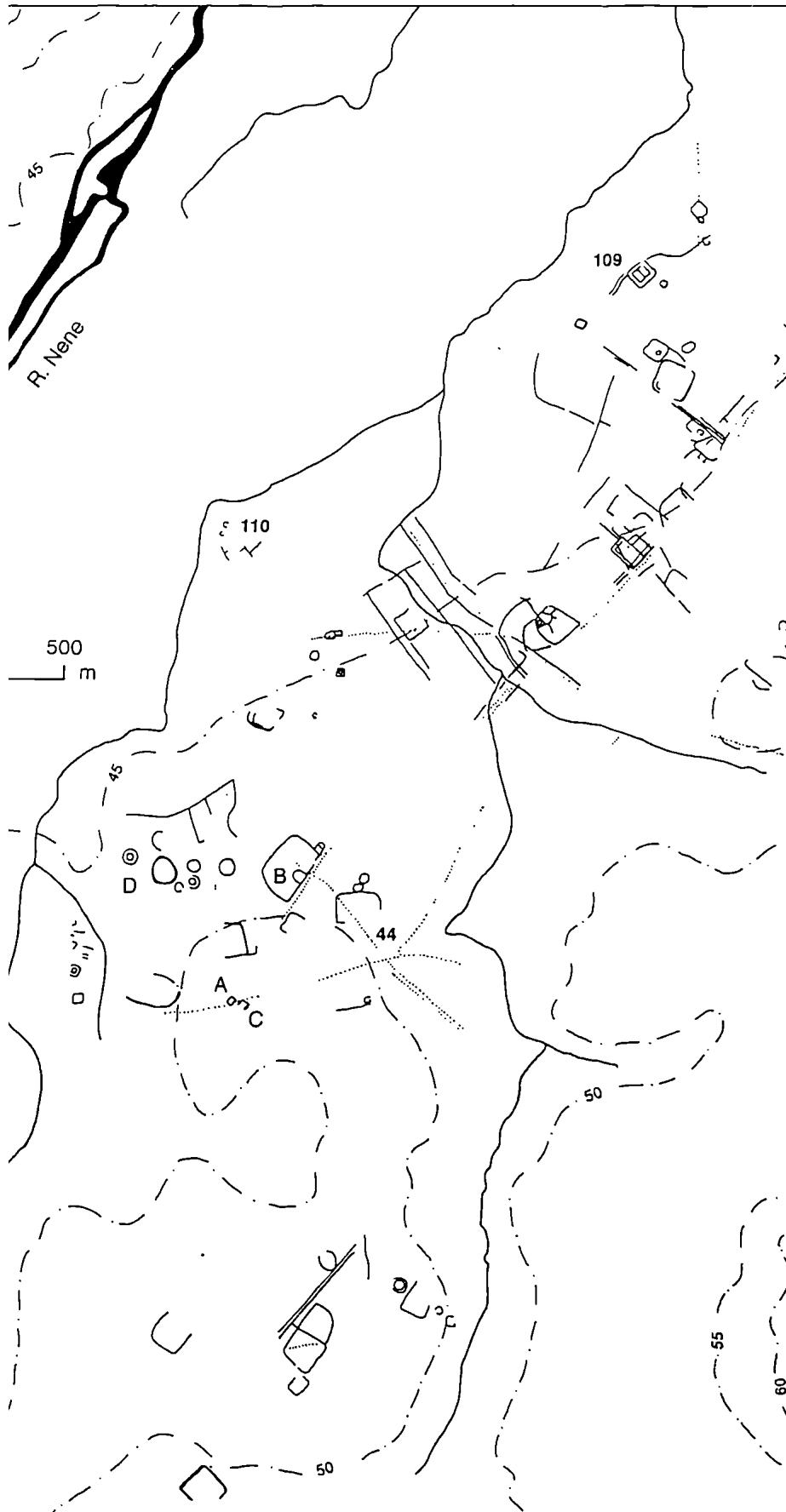

Figure 6.22 Map of the Wollaston/Ecton case study showing the location of gazetteer sites and the detailed study blocks



ark and excavated evidence around Wollaston

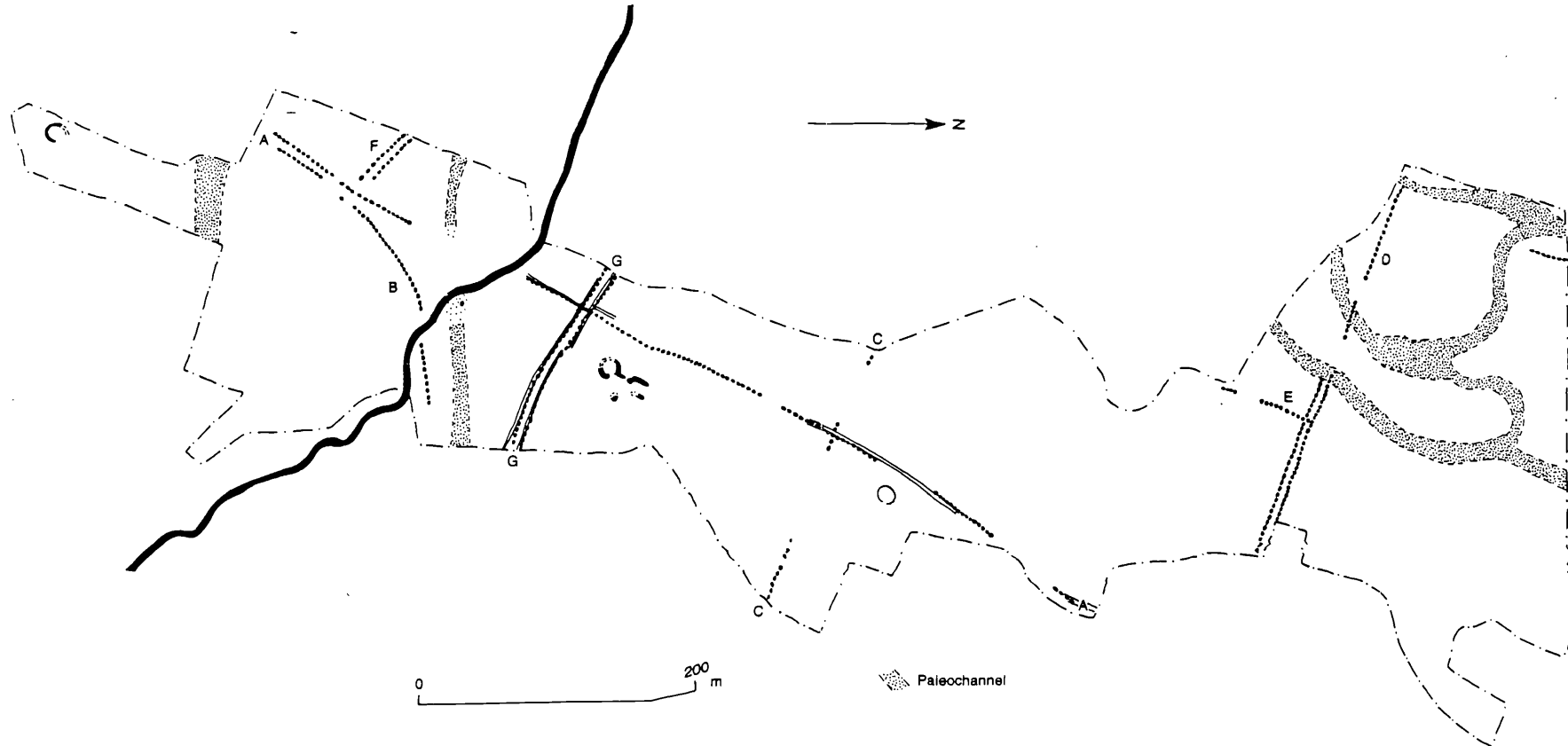

Figure 6.24 Earlier first millennium BC features at Wollaston 107

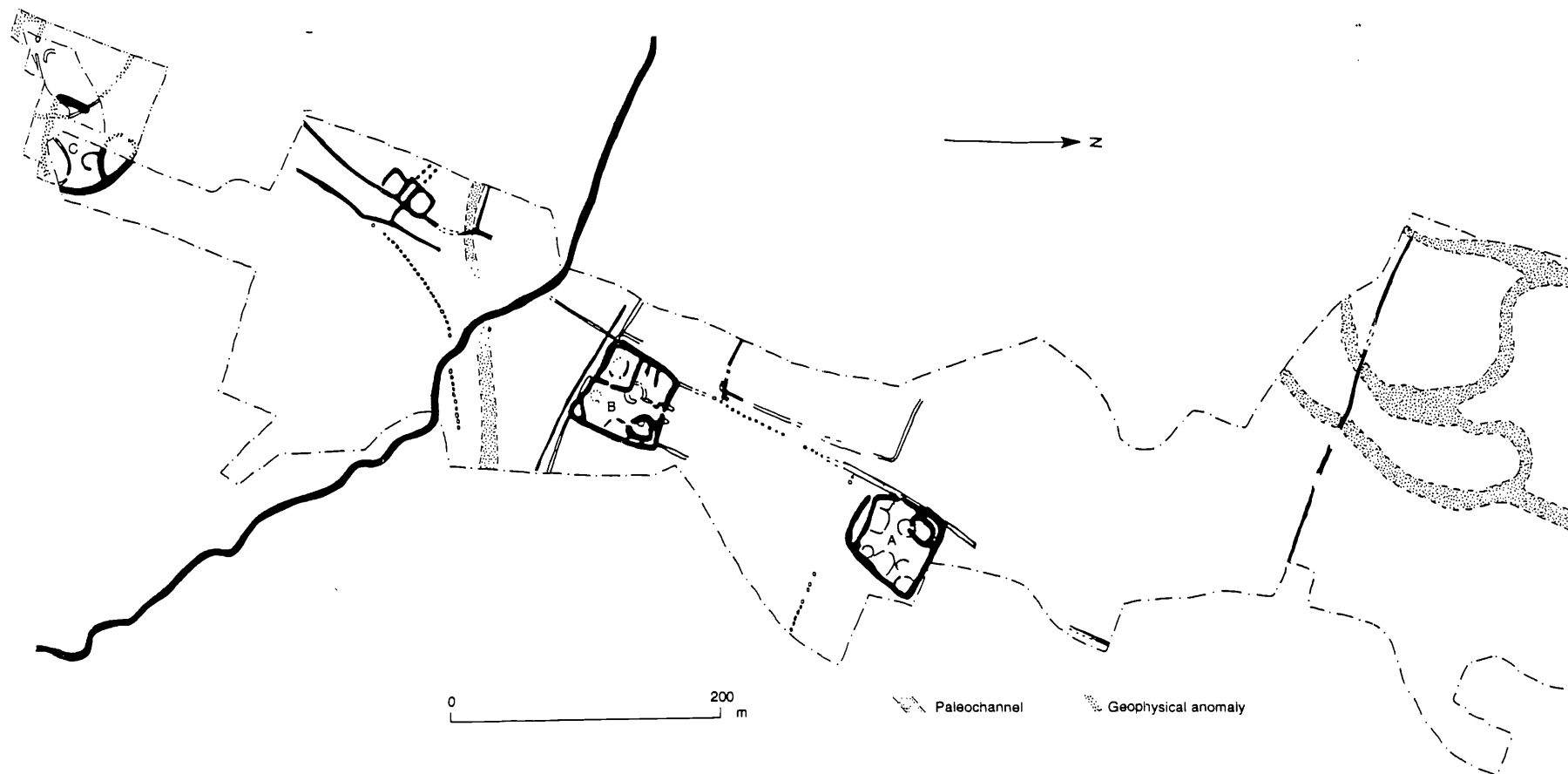

Figure 6.25 Middle iron age features at Wollaston 107

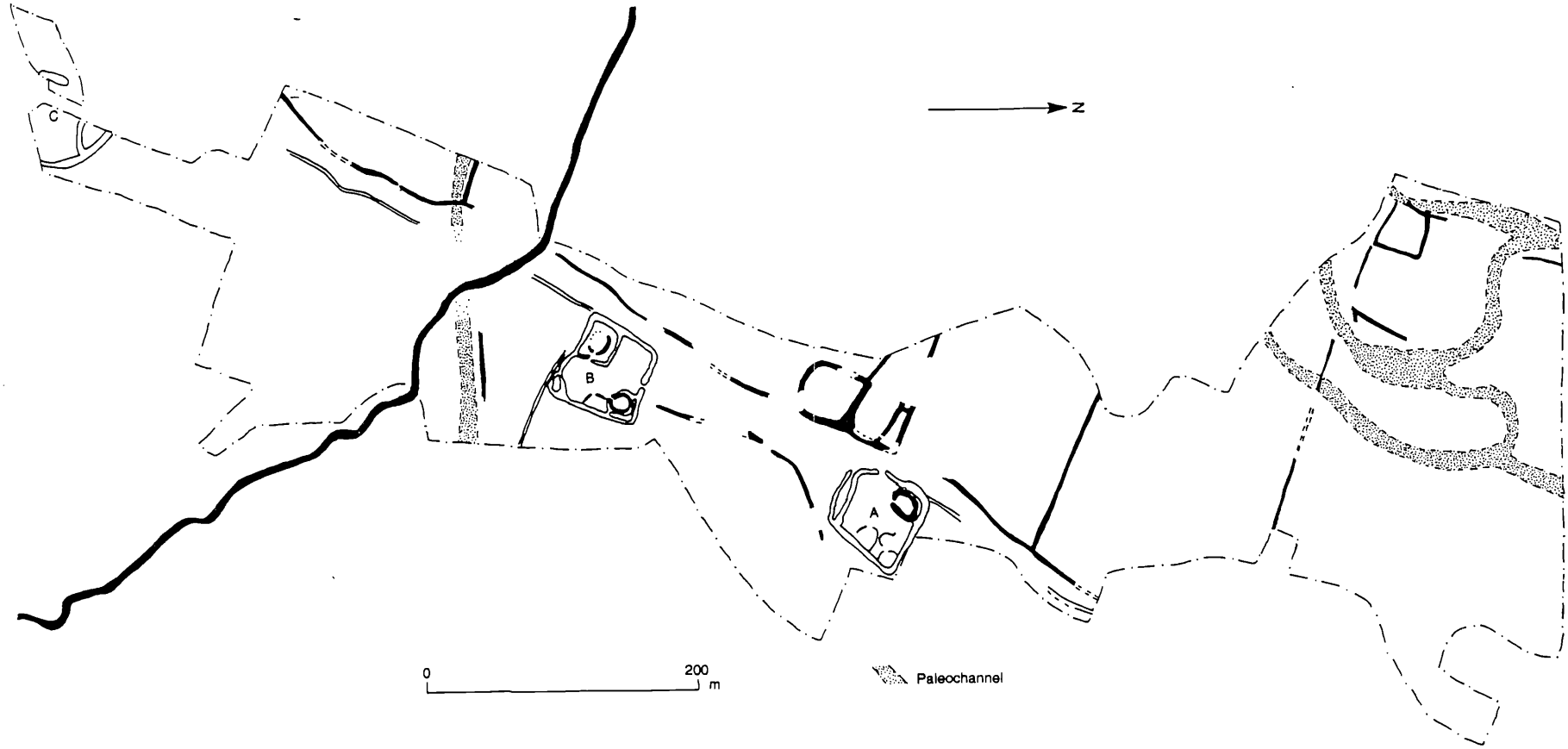

Figure 6.26 Late iron age features at Wollaston 107

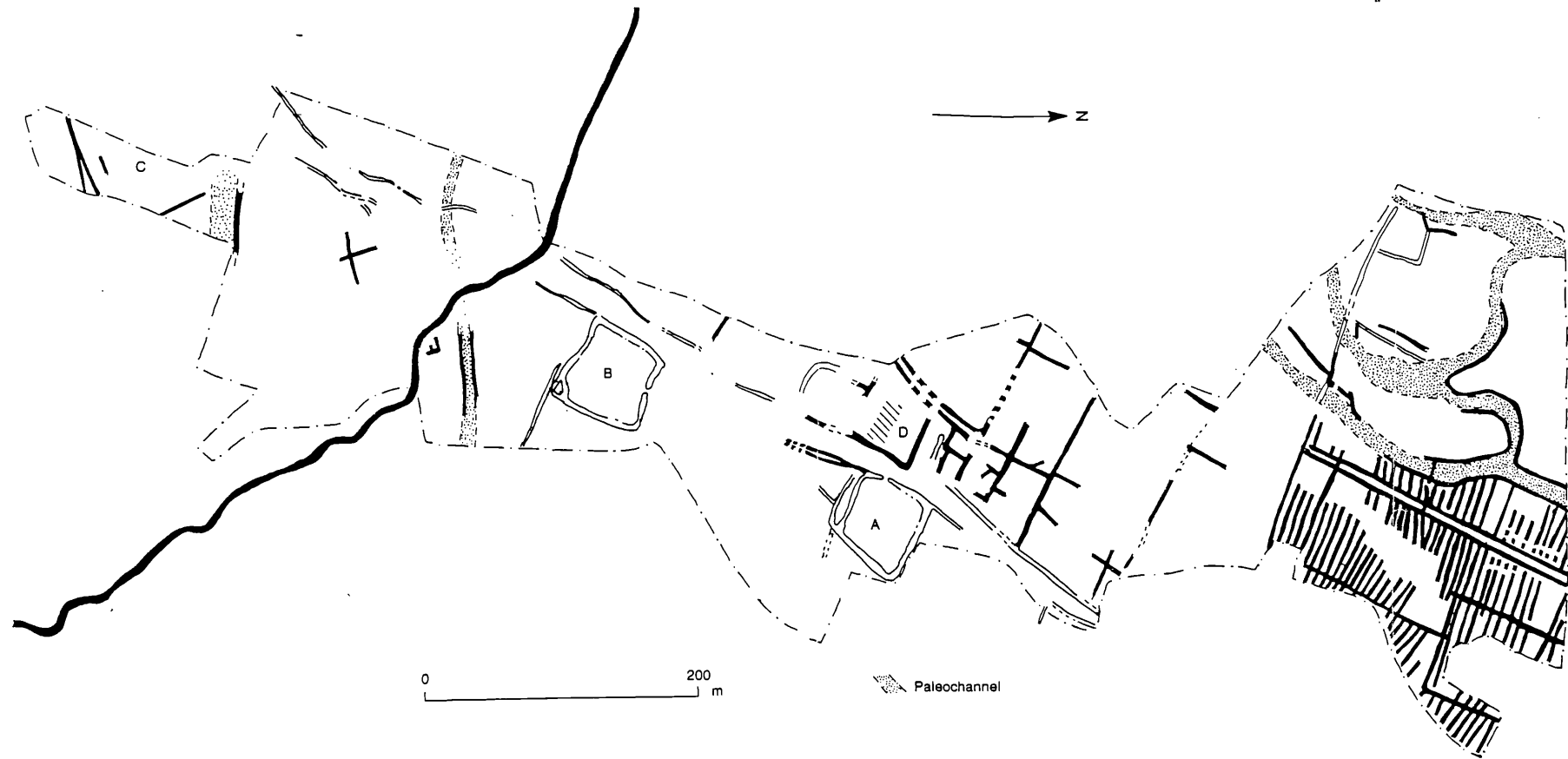

Figure 6.27 Early Roman features at Wollaston 107

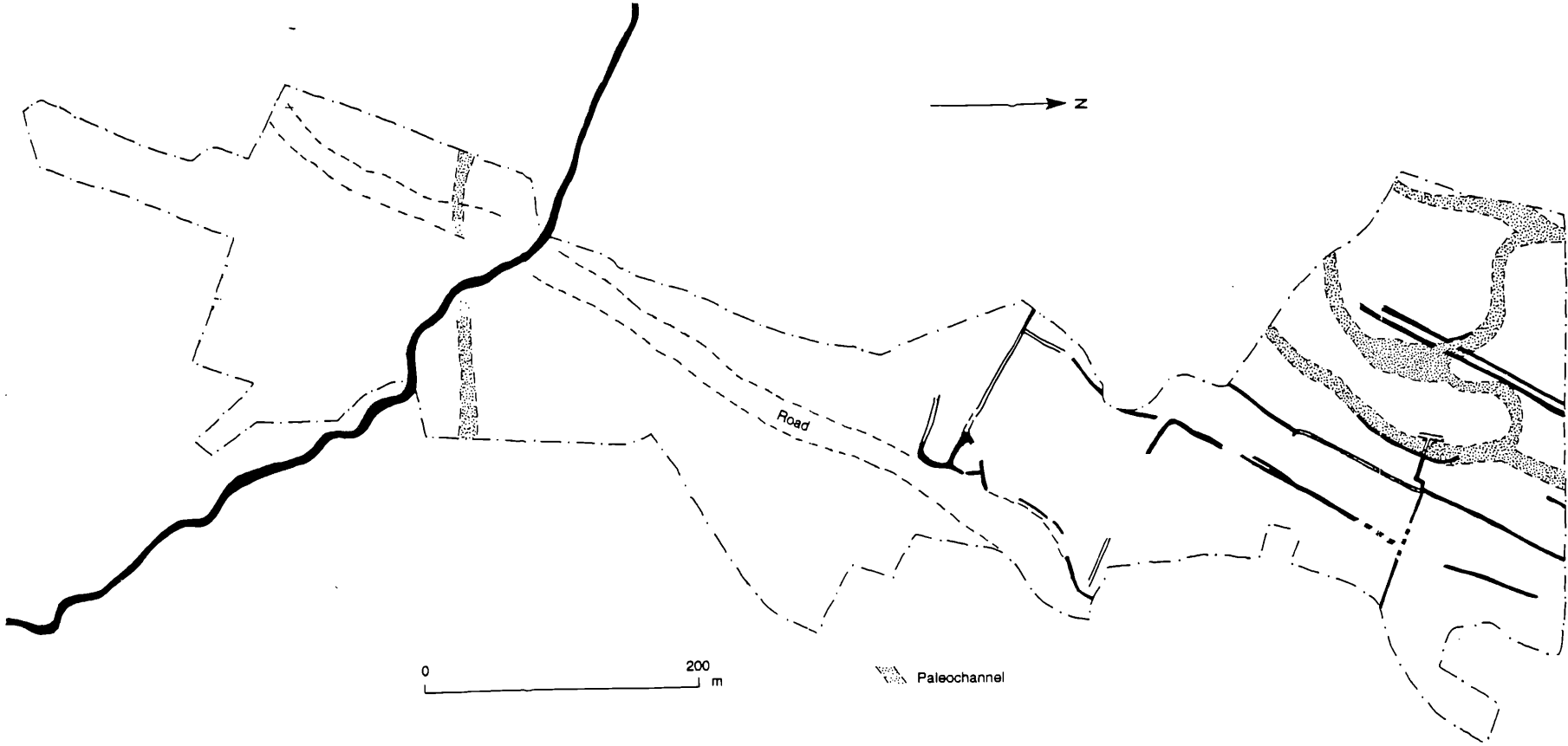

Figure 6.28 Late Roman features at Wollaston 107

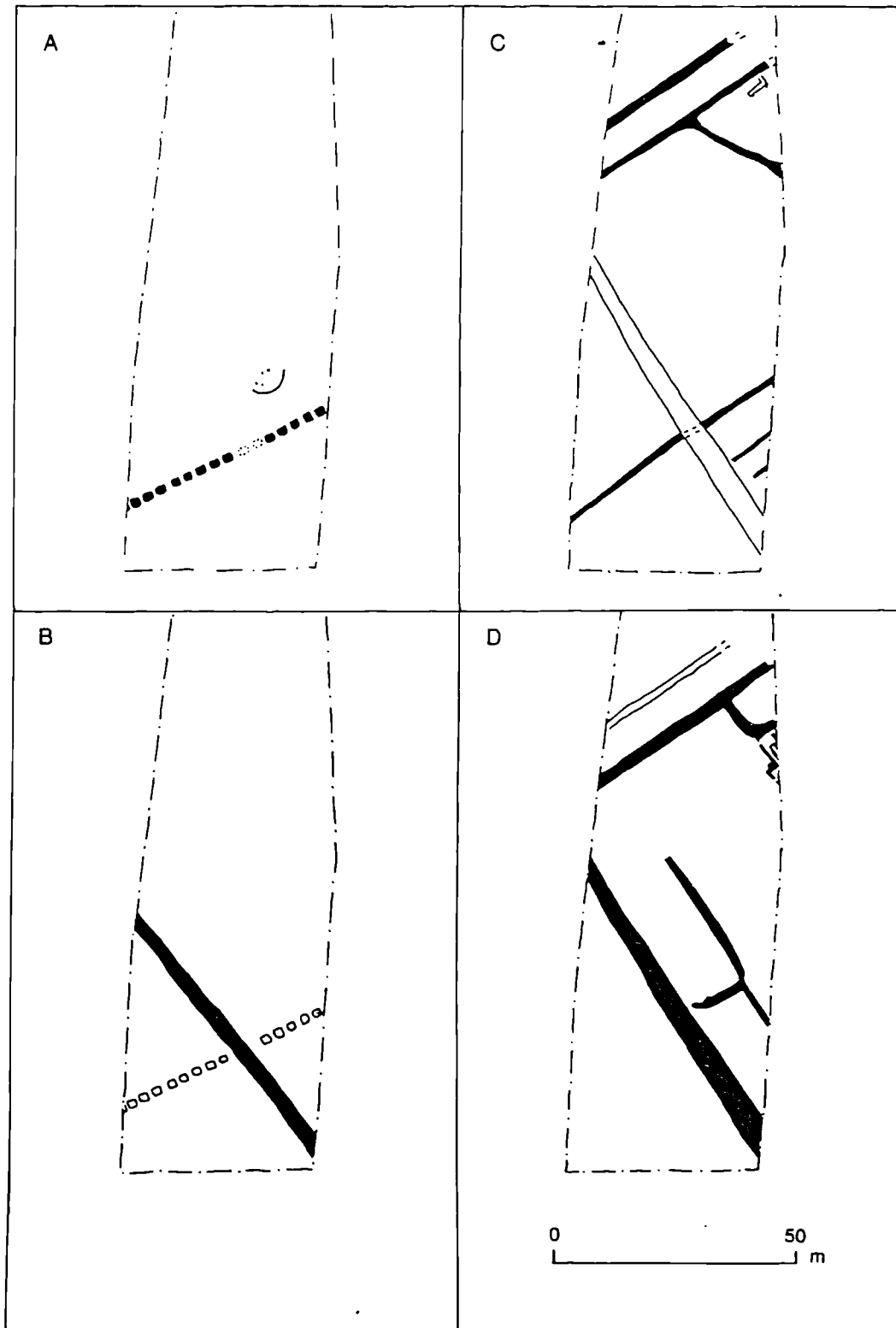

Figure 6.29 Phase plans of the excavations at Wollaston 106

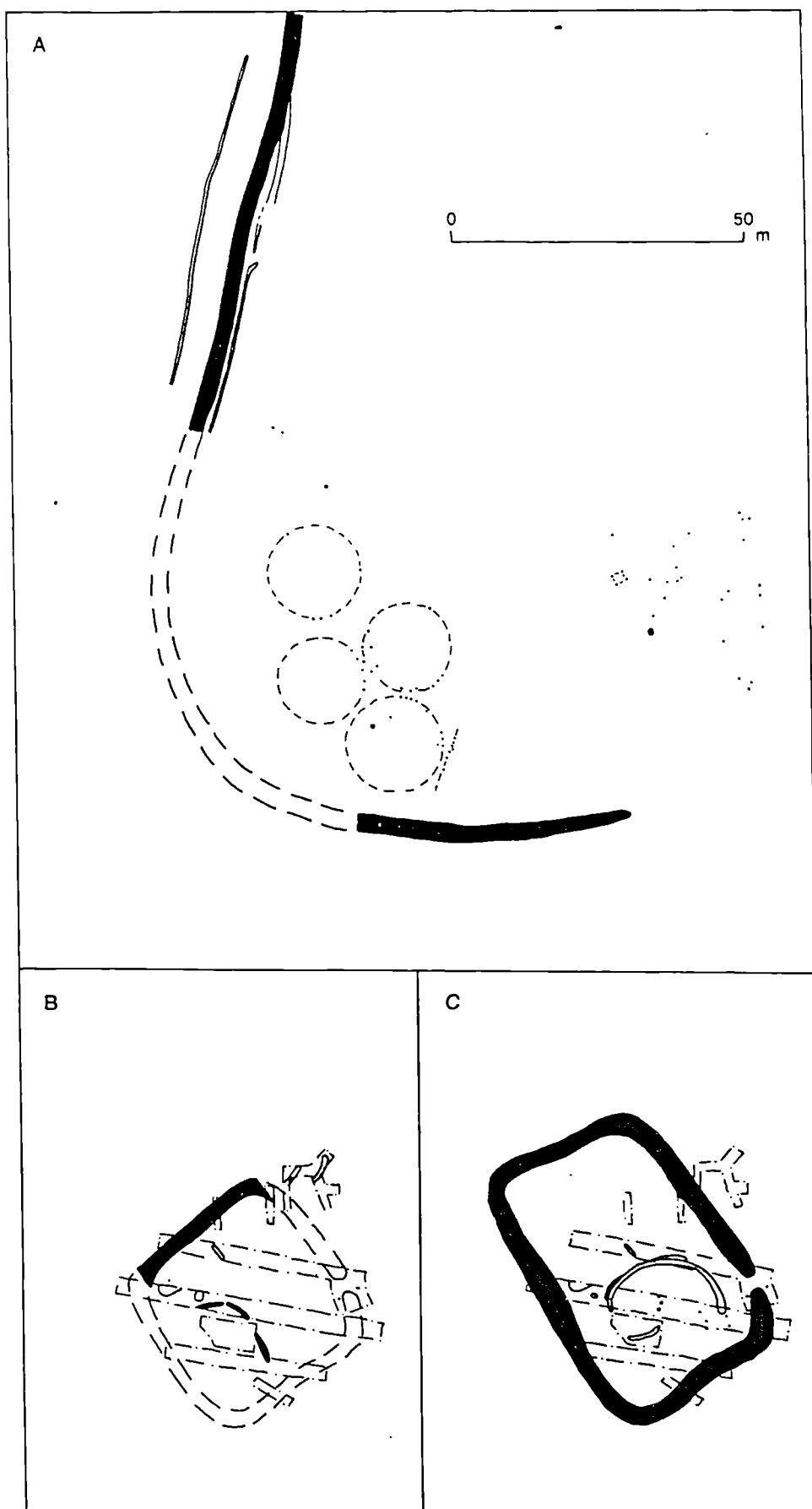

Figure 6.30 A) The earlier first millennium BC settlement at Wollaston 108, and the middle iron age phases at Strixton 87 (B & C)

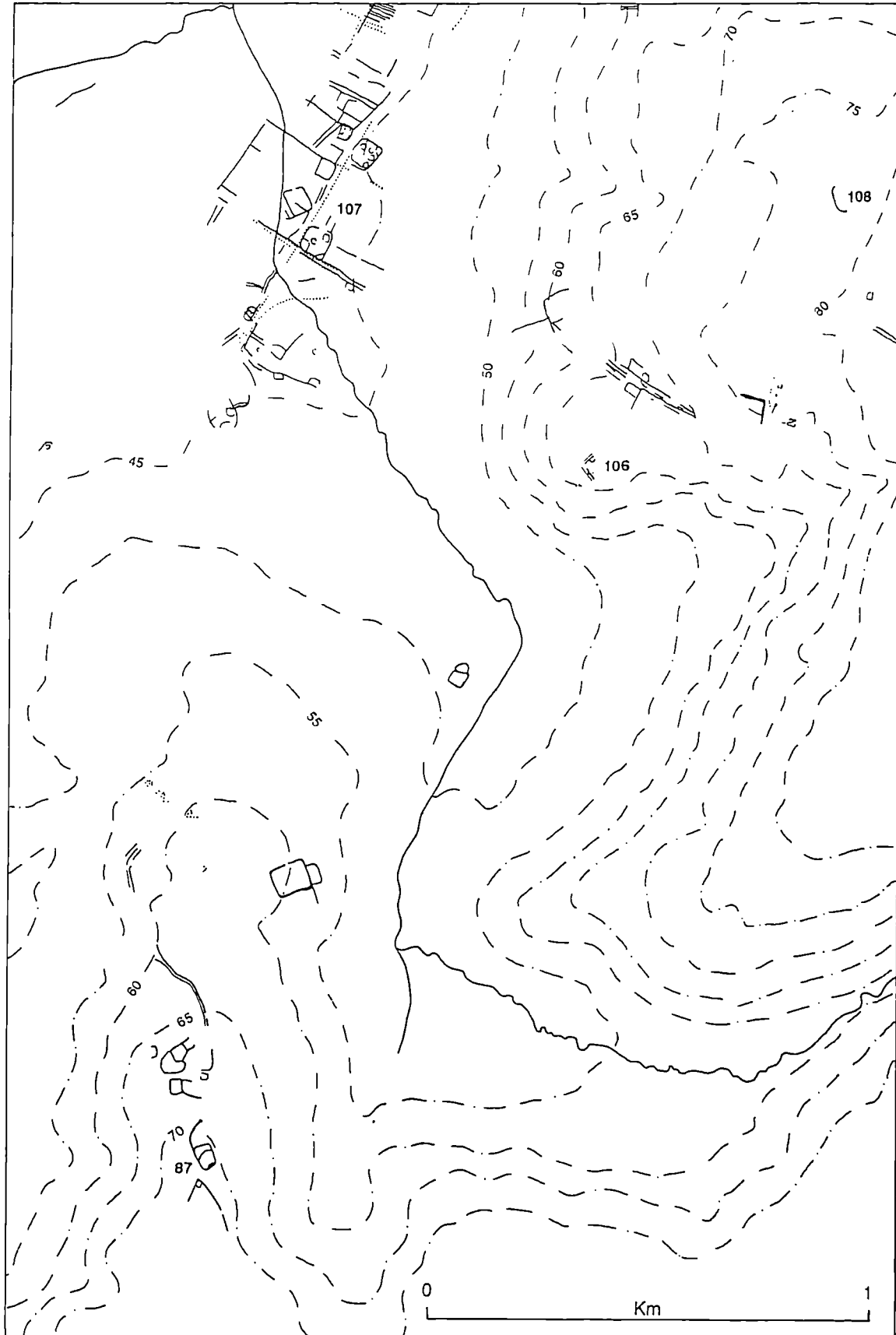

Figure 6.31 Crop mark and excavated evidence around Grendon

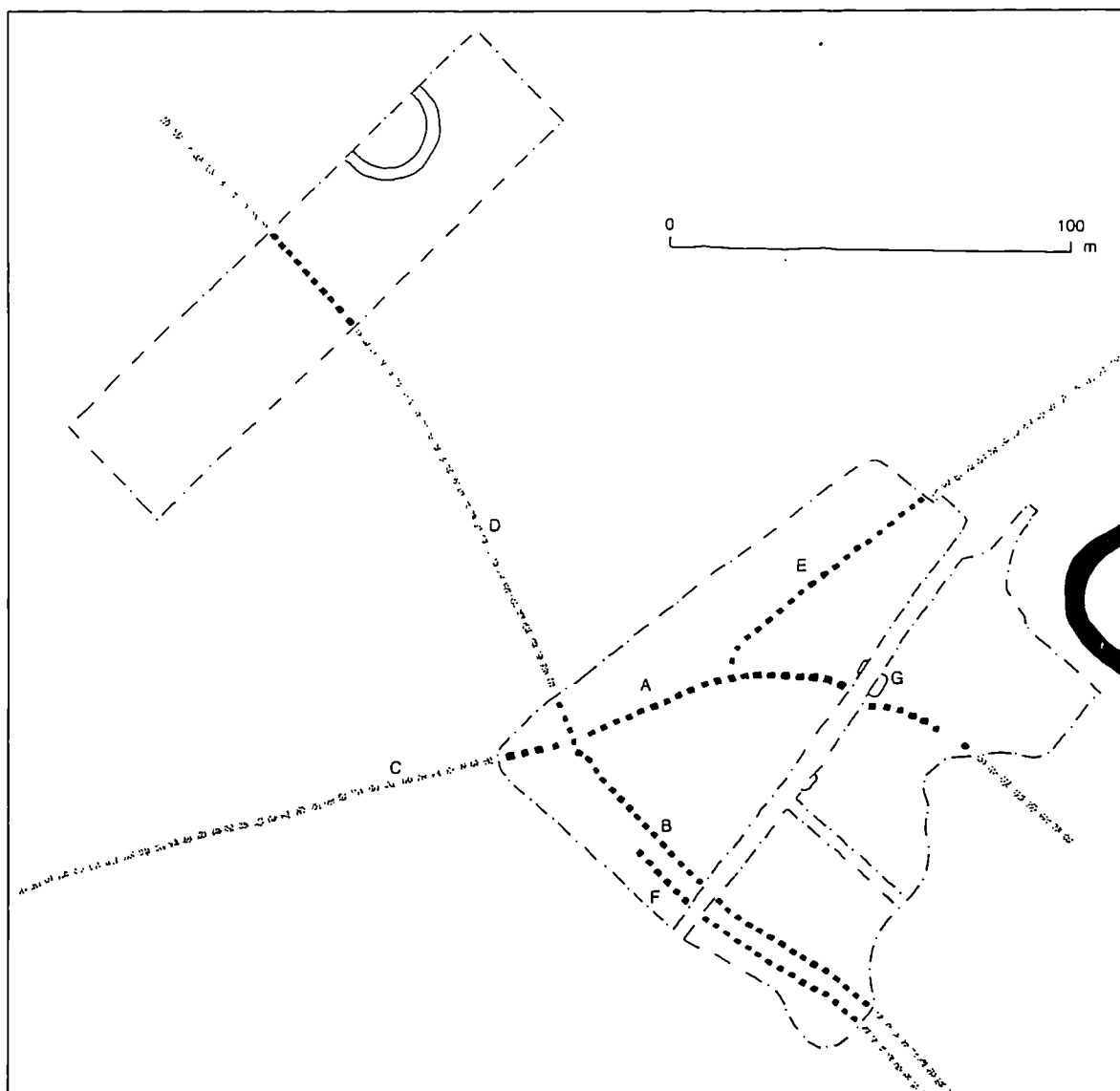

Figure 6.32 Earlier first millennium BC features at Grendon 44

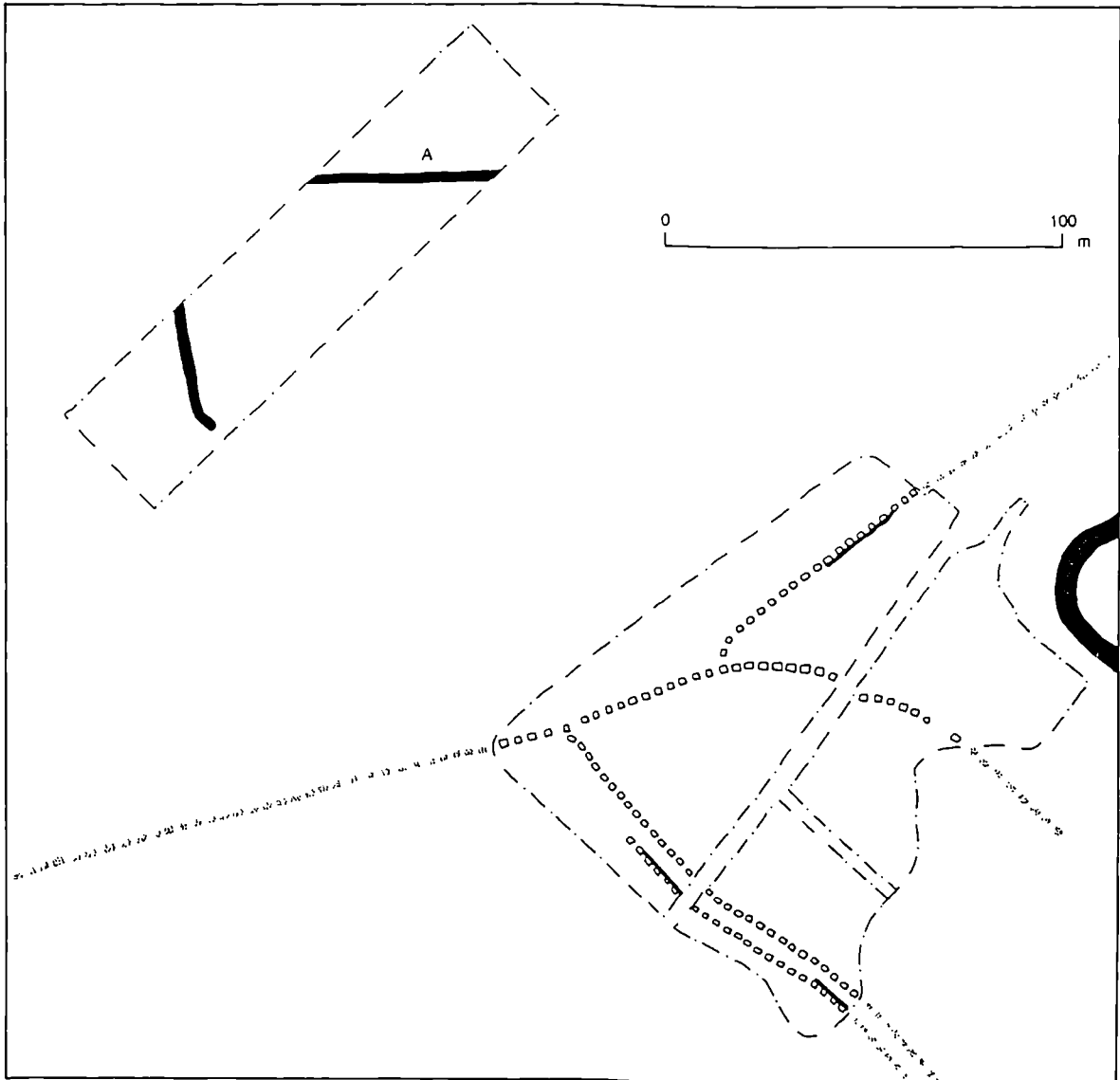

Figure 6.33 Later first millennium BC features at Grendon 44

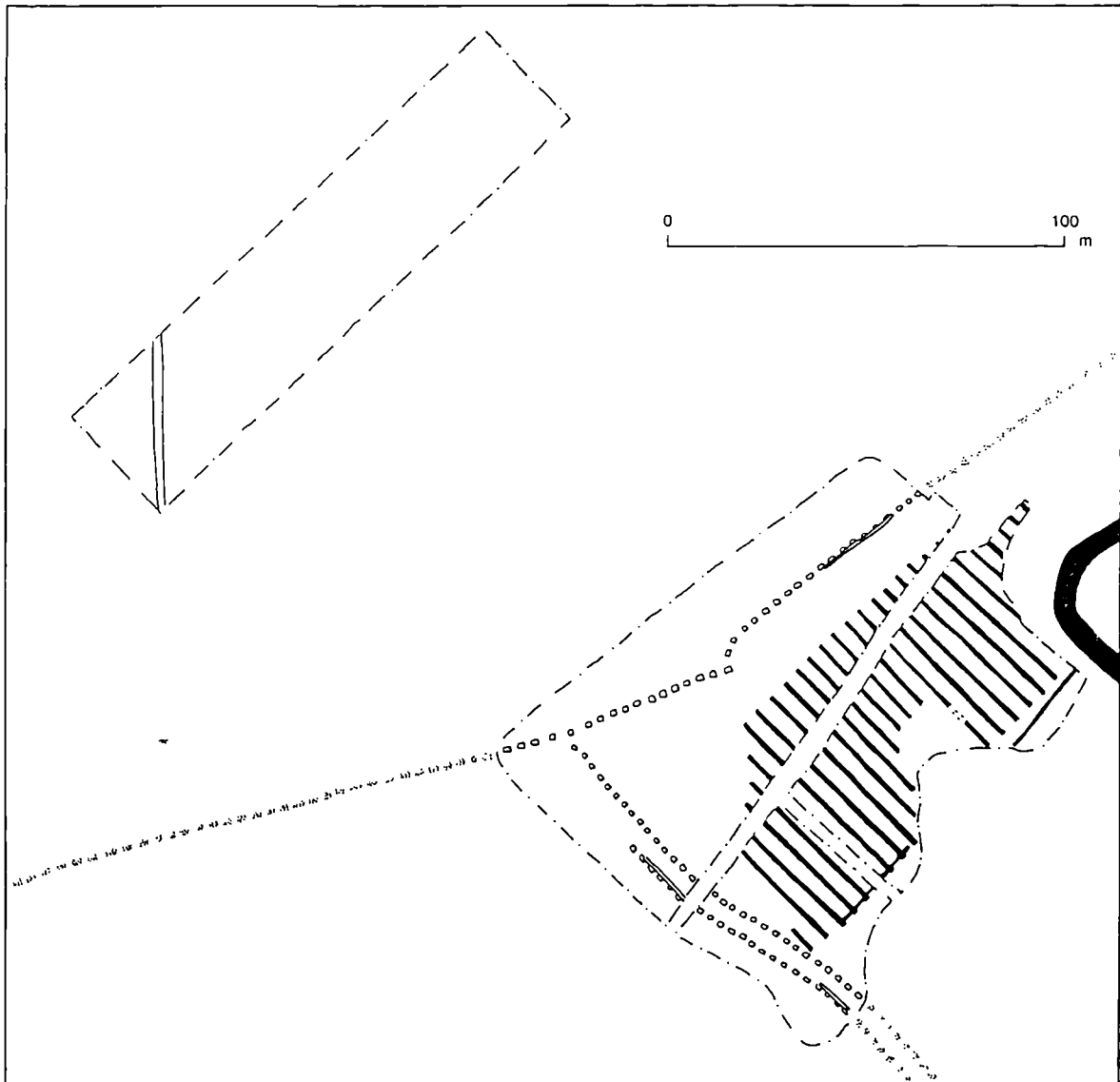

Figure 6.34 Earlier Roman features at Grendon 44

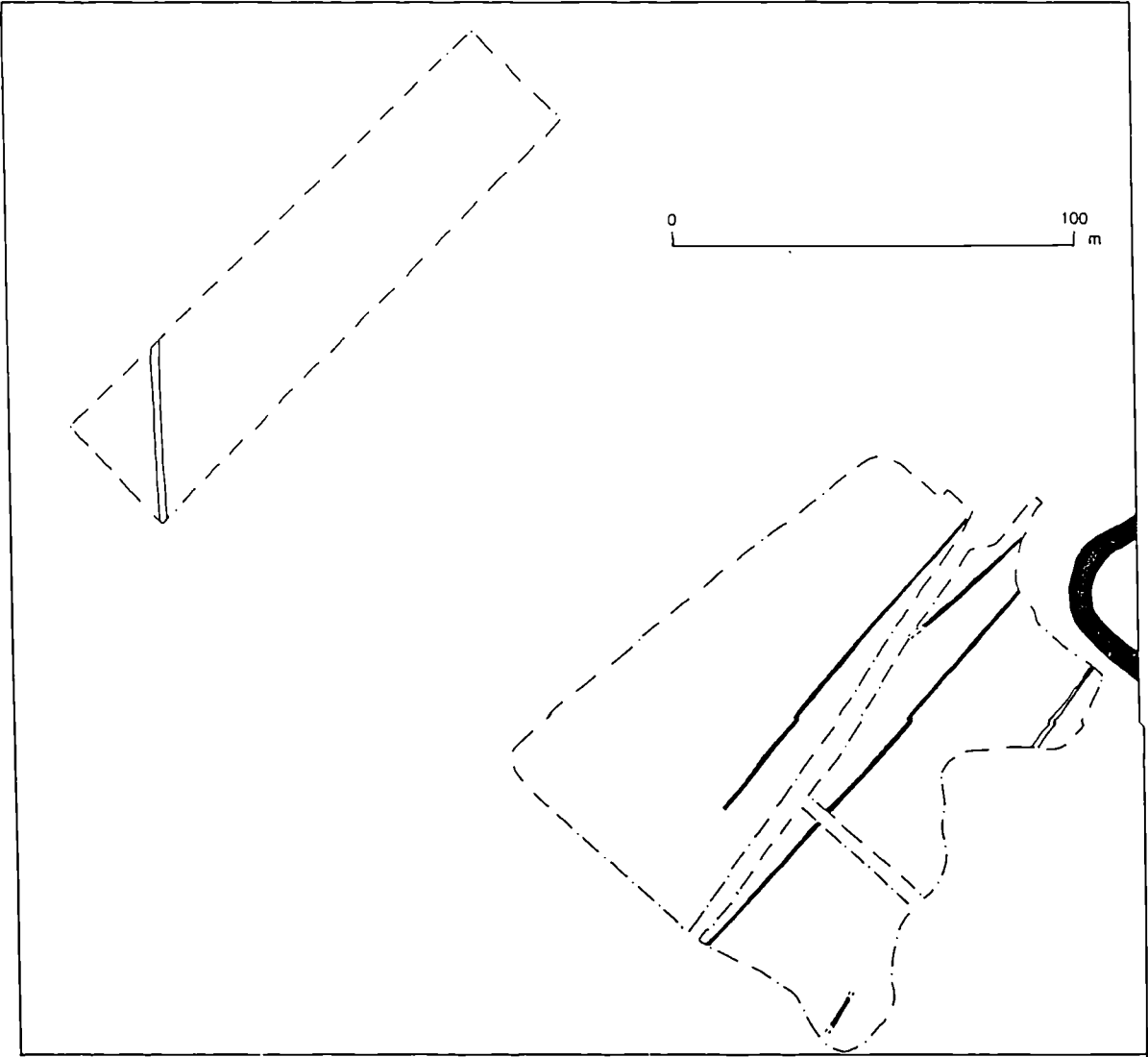

Figure 6.35 Later Roman features at Grendon 44

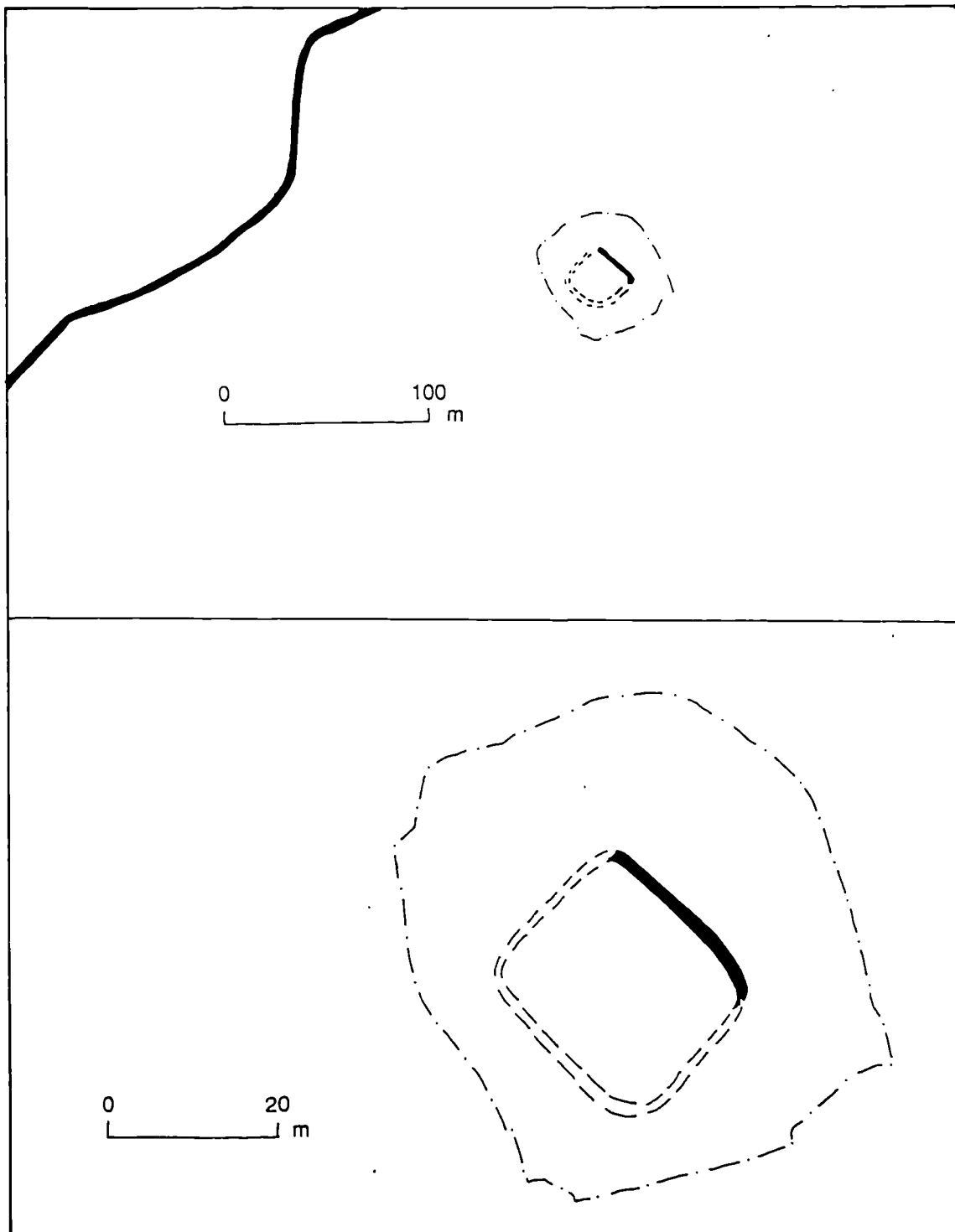

Figure 6.36 Wollaston 109, iron age phase 1

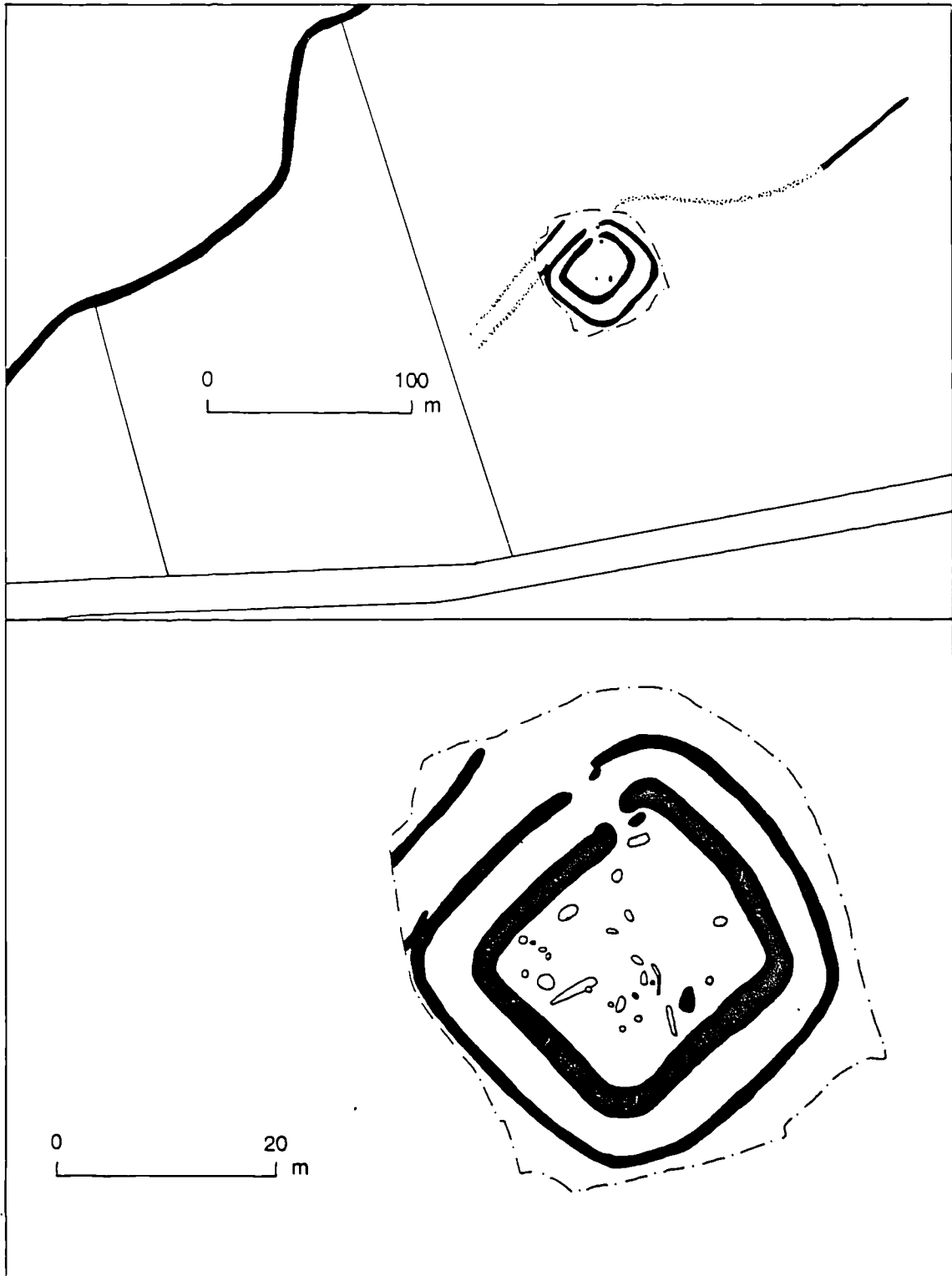

Figure 6.37 Wollaston 109, iron age phase 2

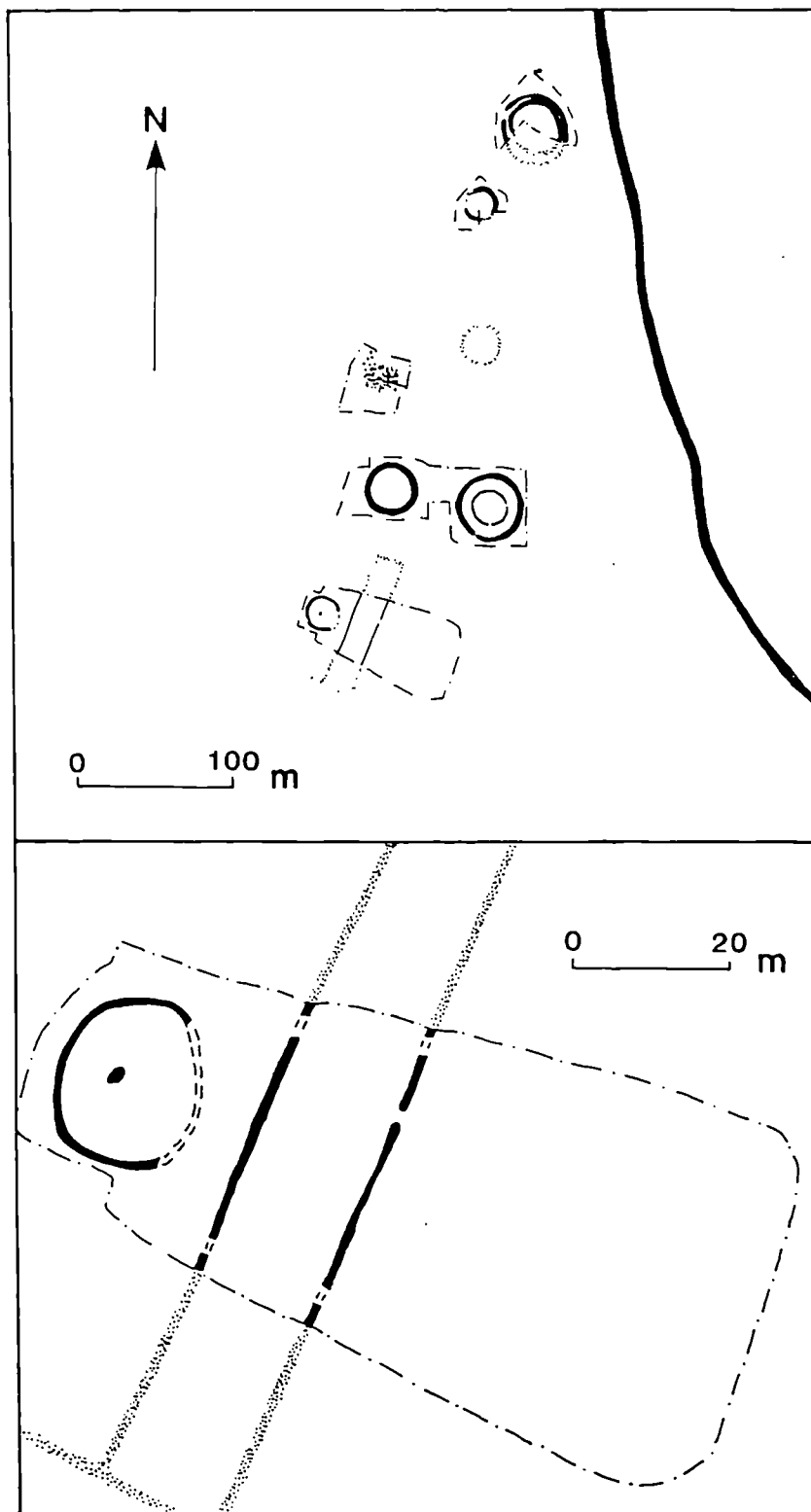

Figure 6.38 Earlier prehistoric features at Grendon 43

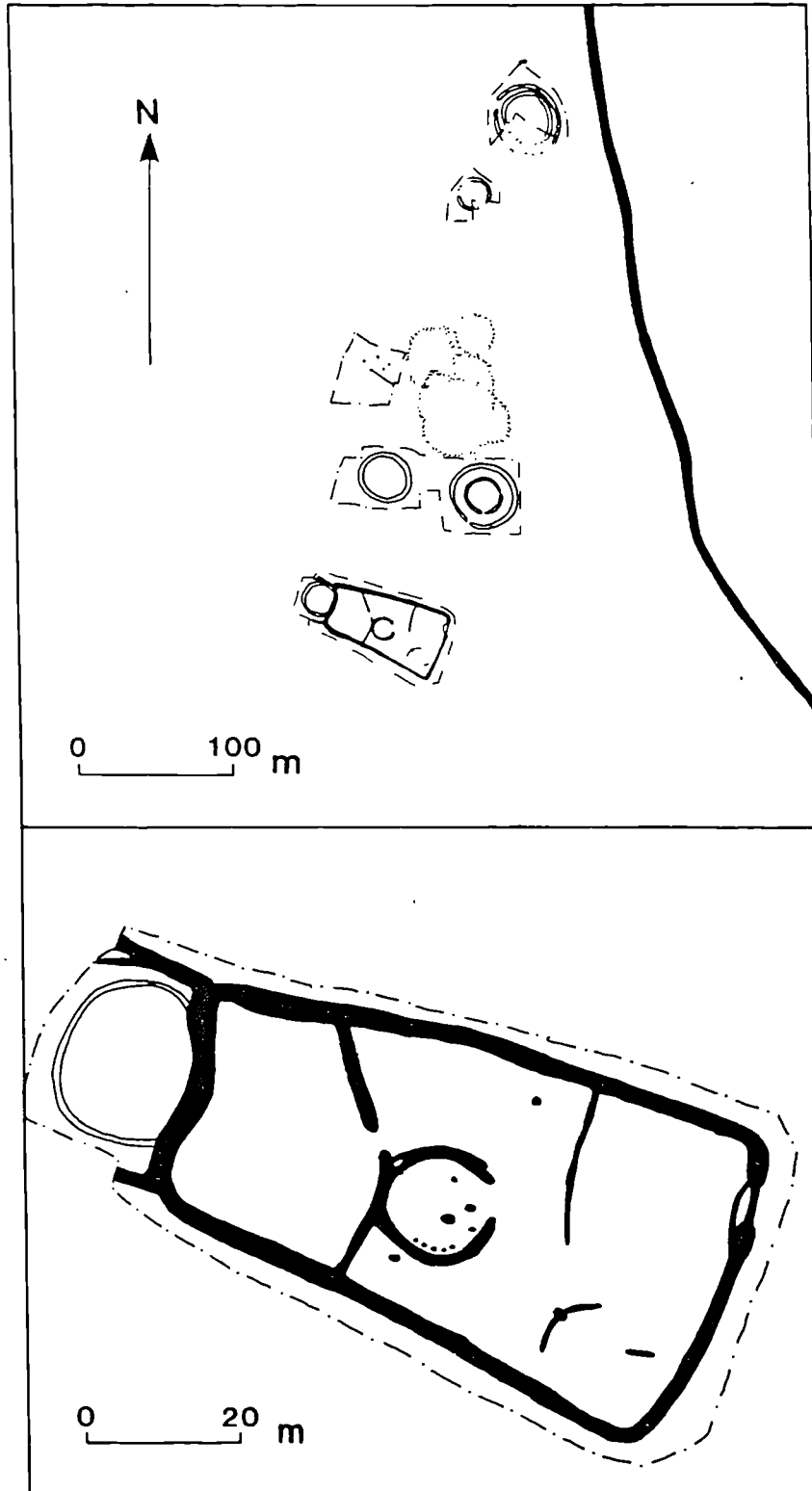

Figure 6.39 Middle iron age features at Grendon 43

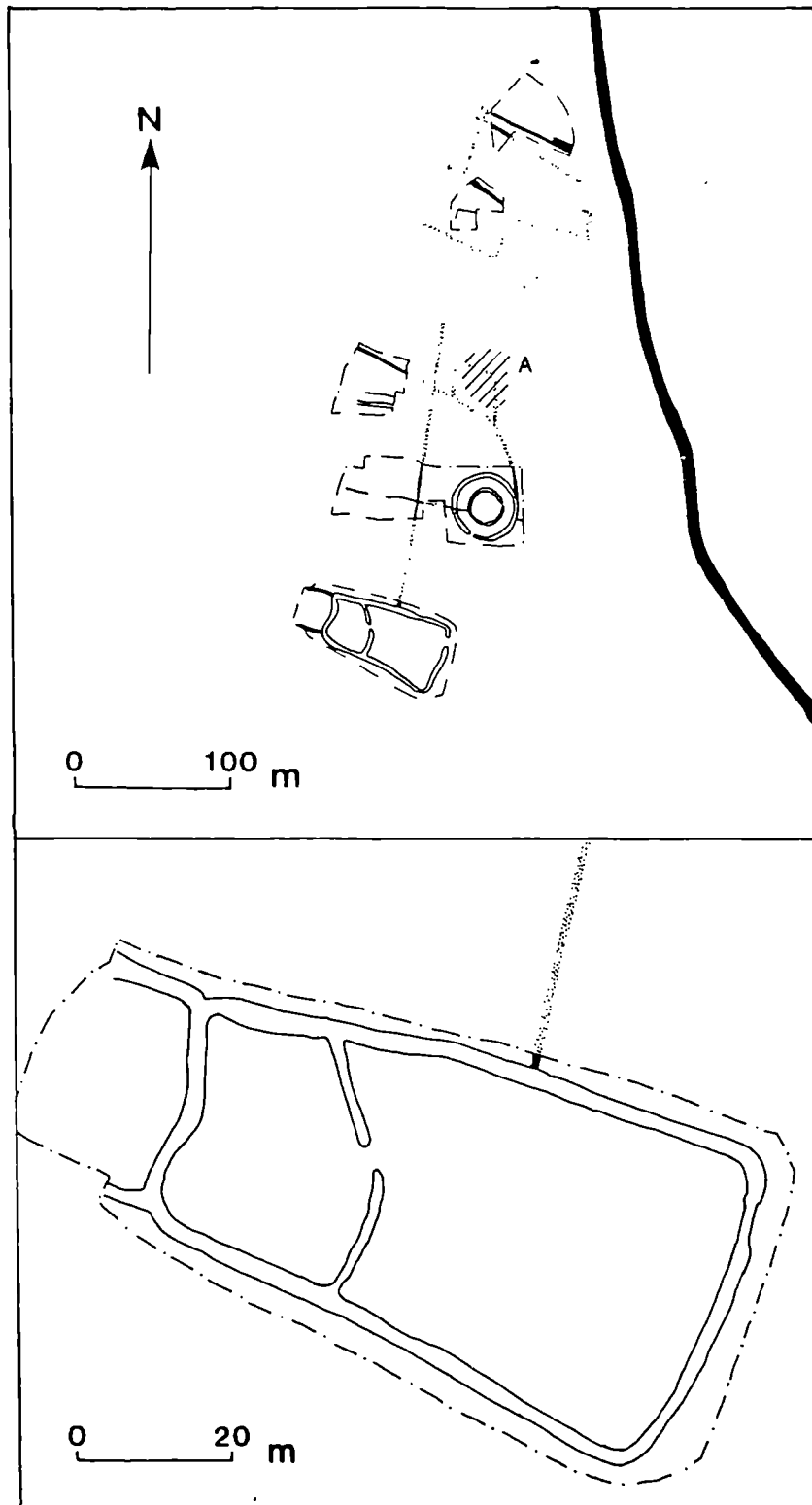

Figure 6.40 Late iron age and Roman features at Grendon 43

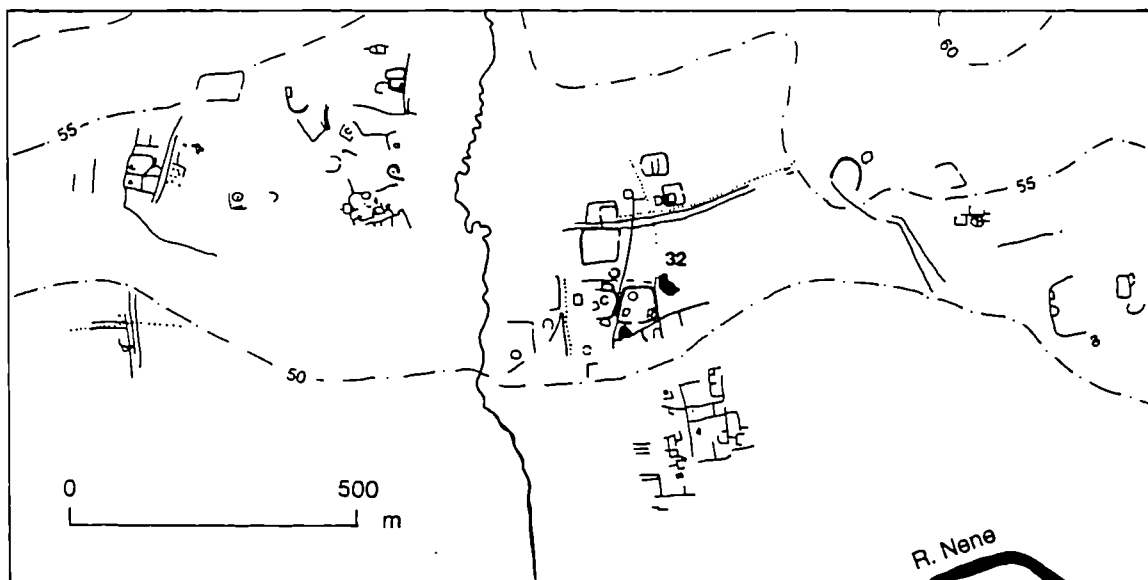

Figure 6.41 Crop marks and excavated evidence around Earls Barton

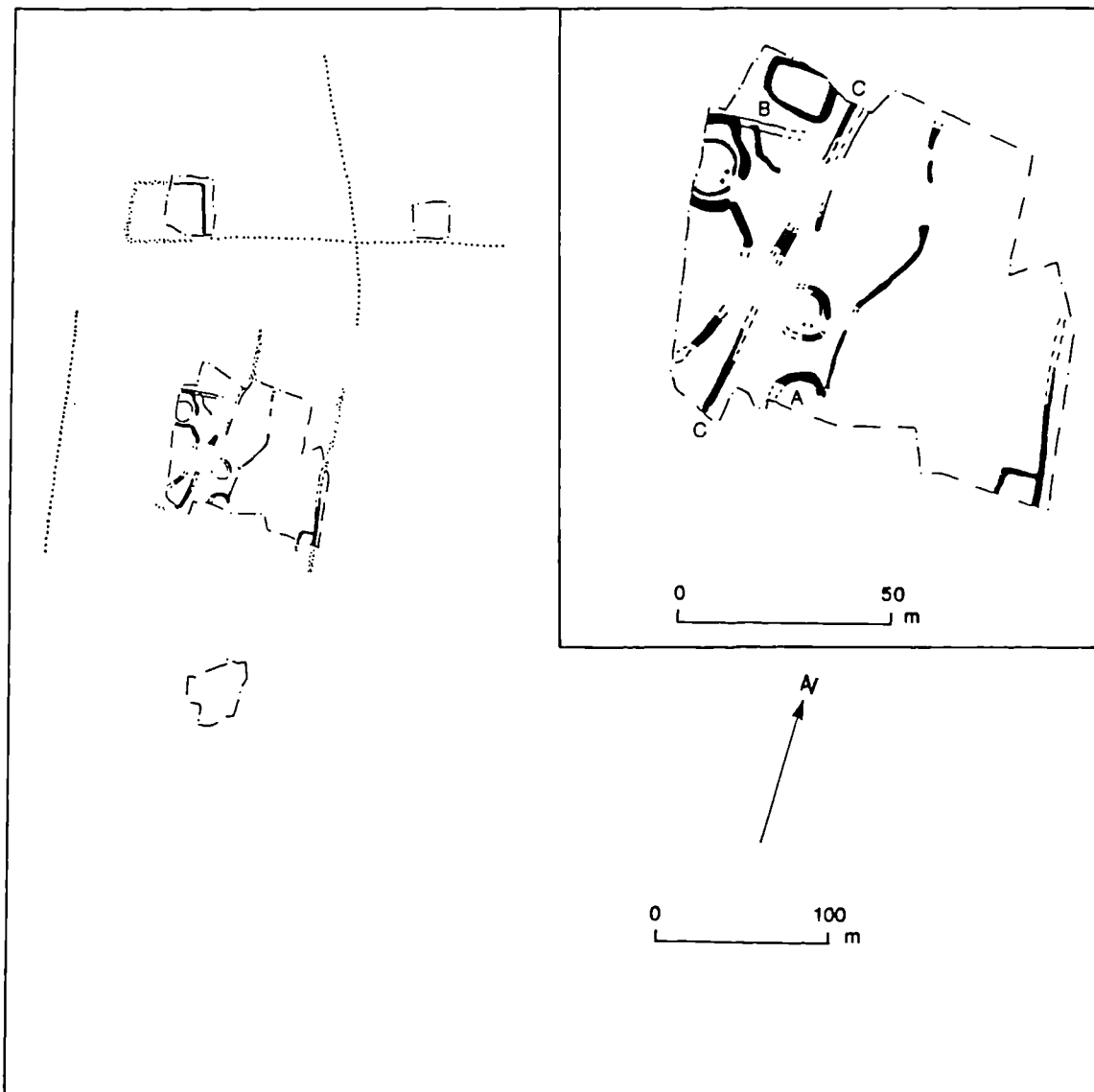

Figure 6.42 Early features at Earls Barton 32

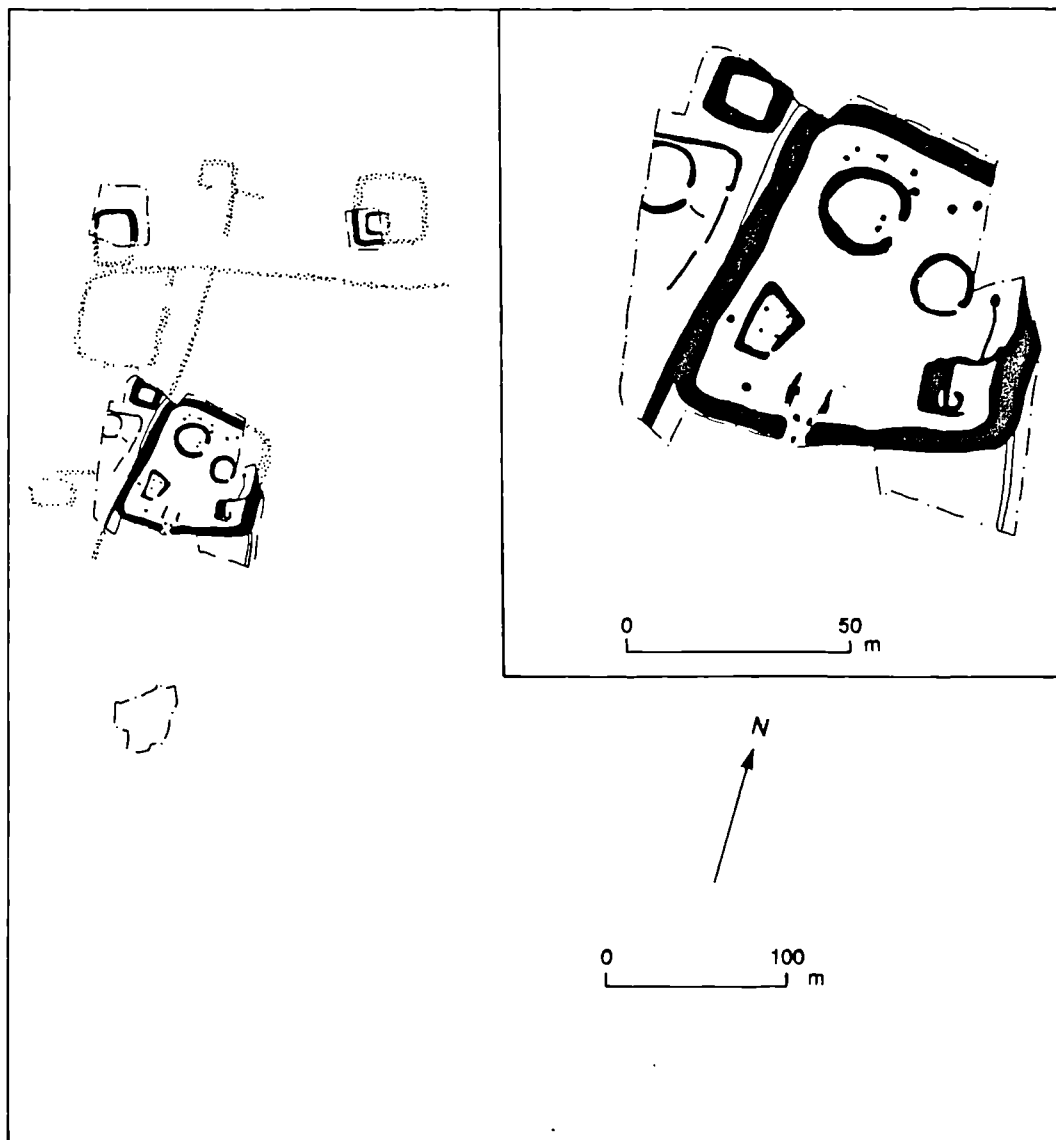

Figure 6.43 Middle iron age features at Earls Barton 32

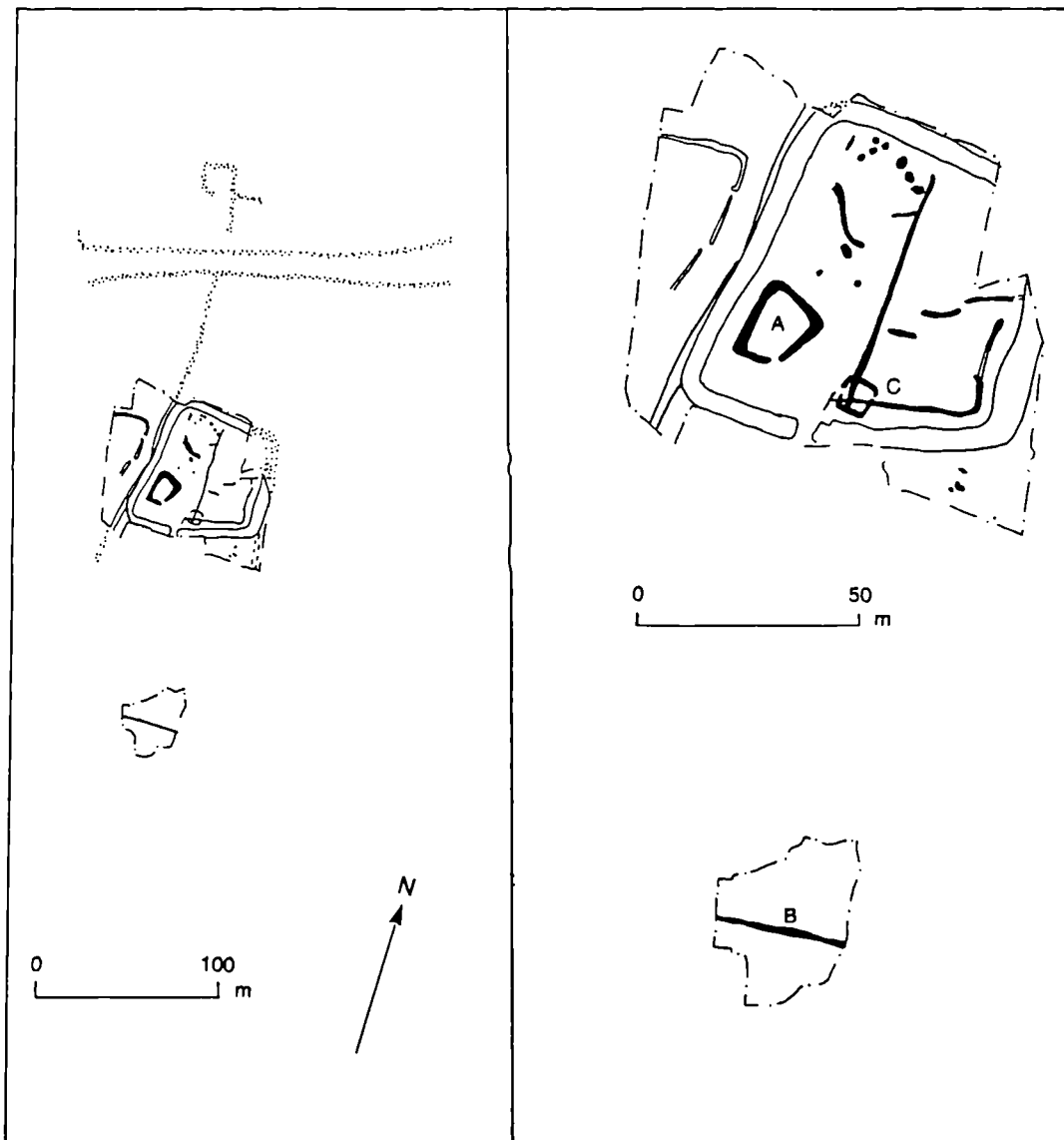

Figure 6.44 Late iron age features at Earls Barton 32

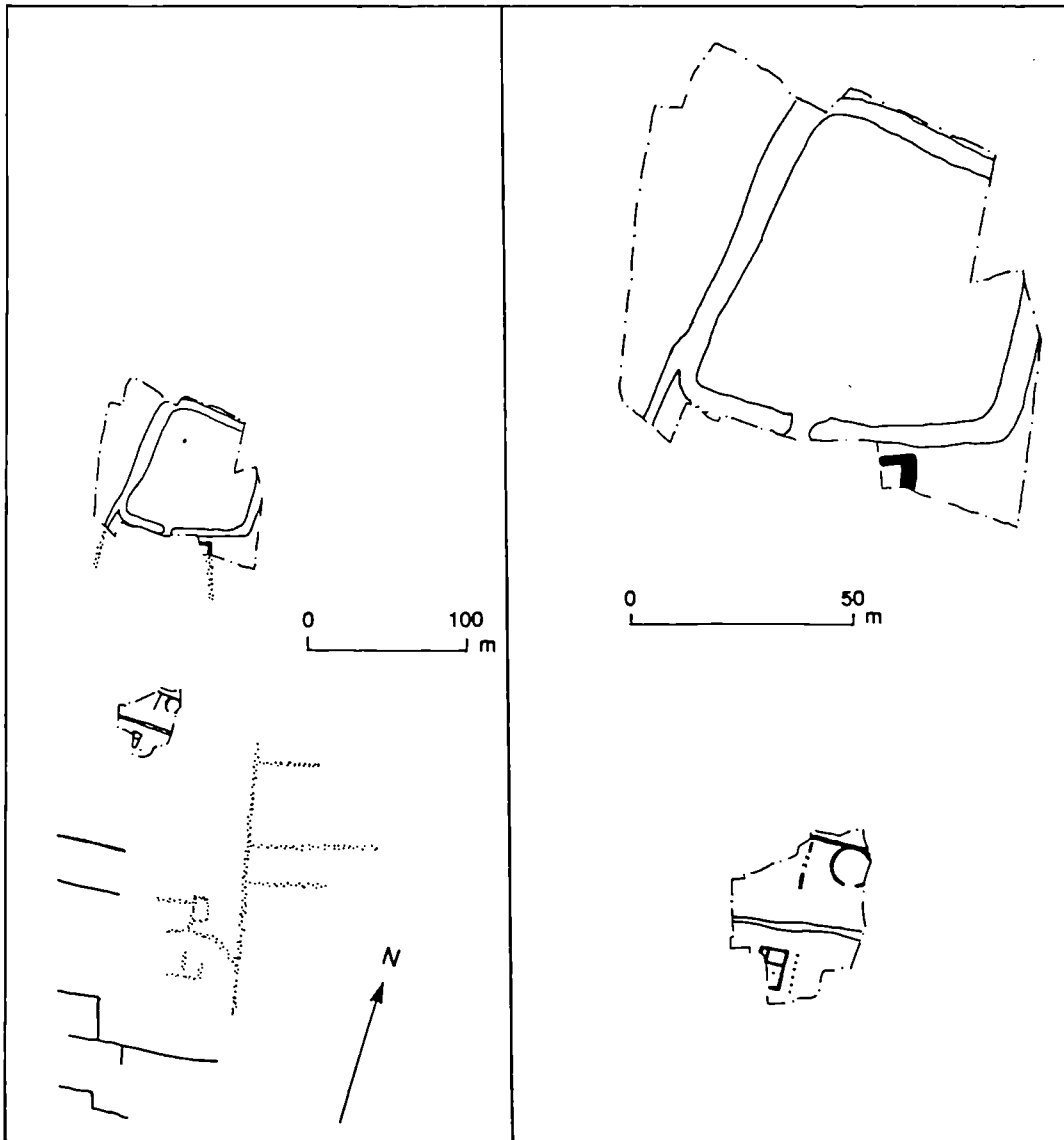

Figure 6.45 Early Roman features at Earls Barton 32

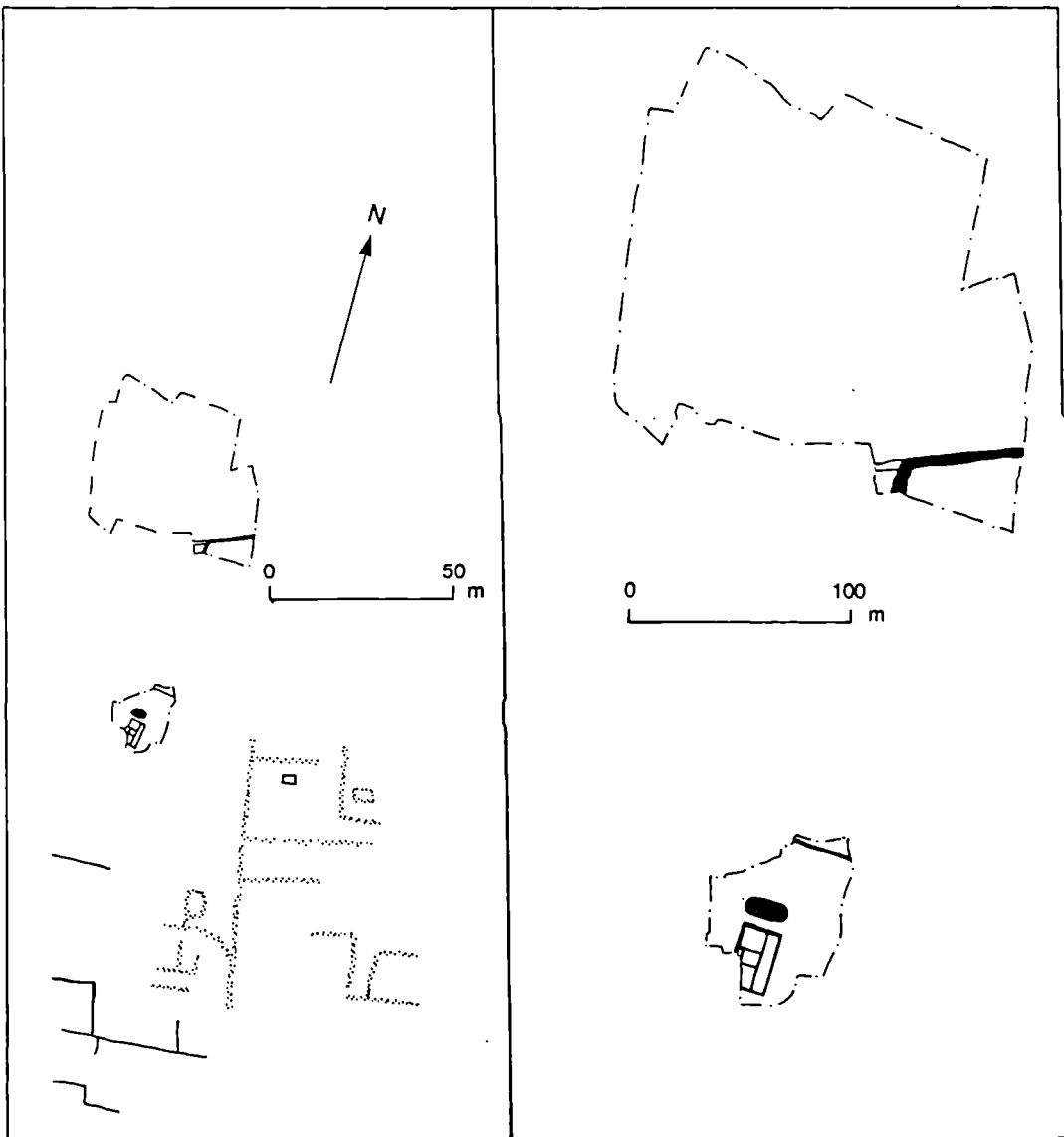

Figure 6.46 Late Roman features at Earls Barton 32

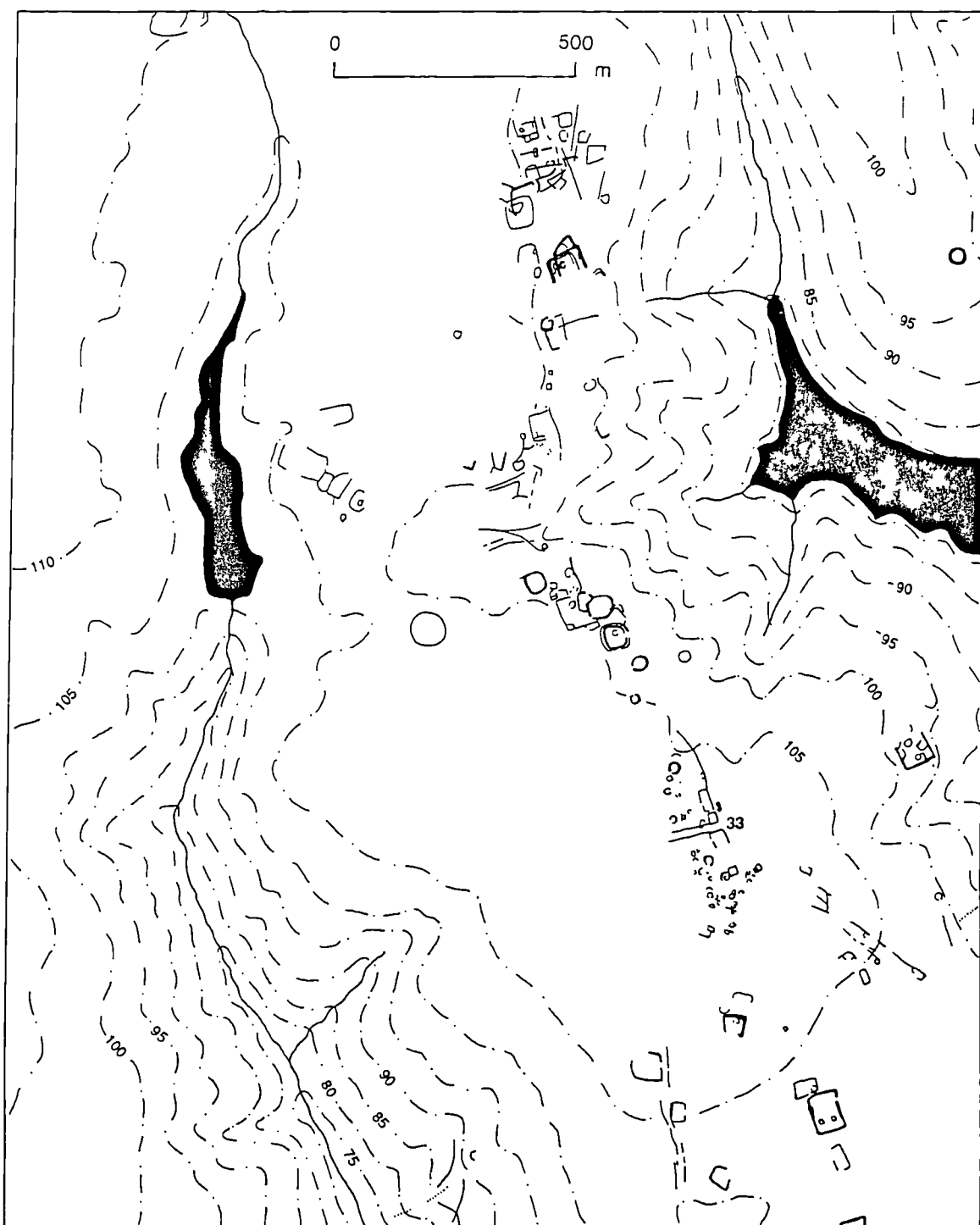

Figure 6.47 Crop marks and excavated evidence around Ecton

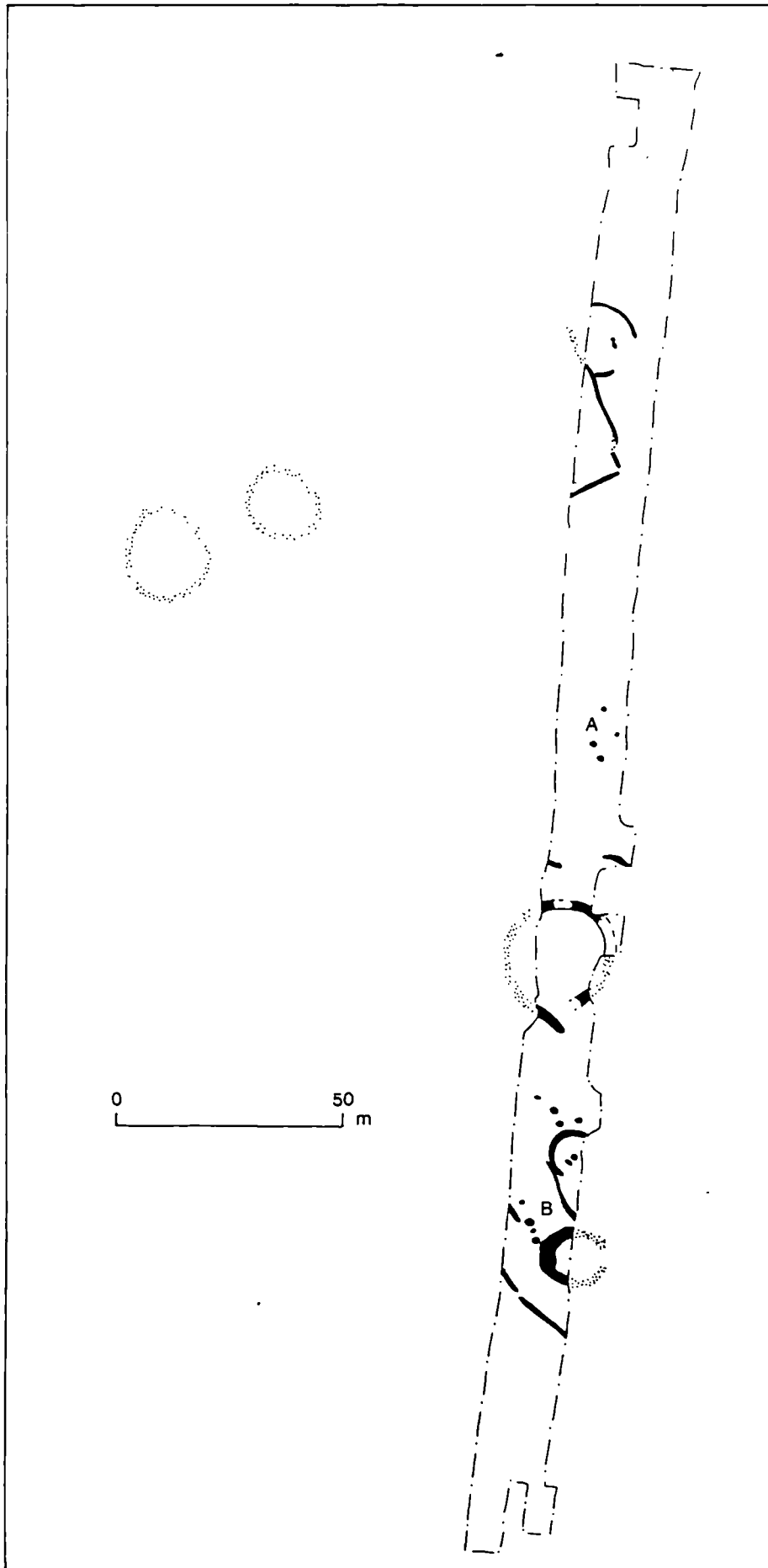

Figure 6.48 Ecton 33 phase 1 features

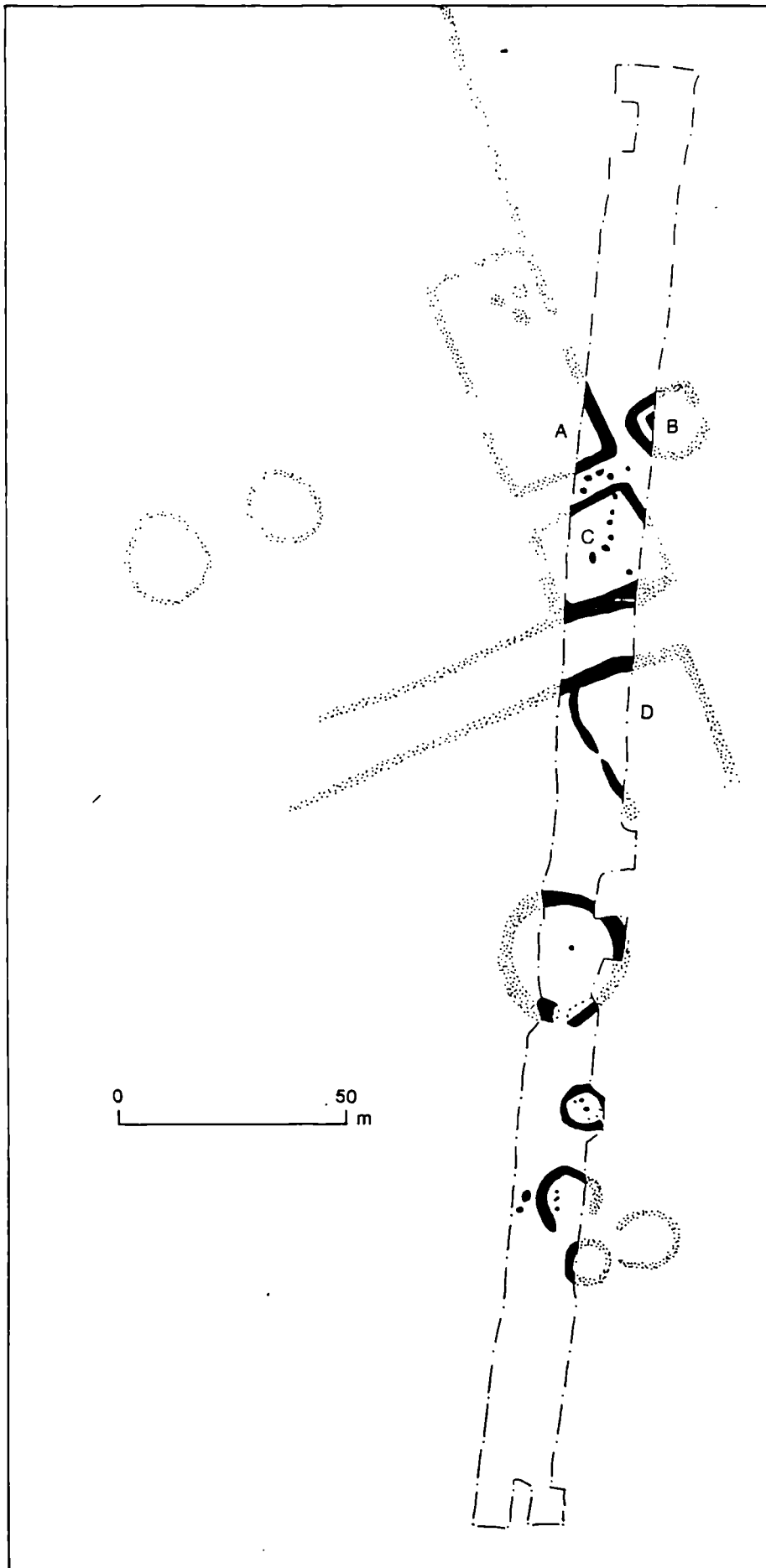

Figure 6.49 Ecton 33 phase 2 features

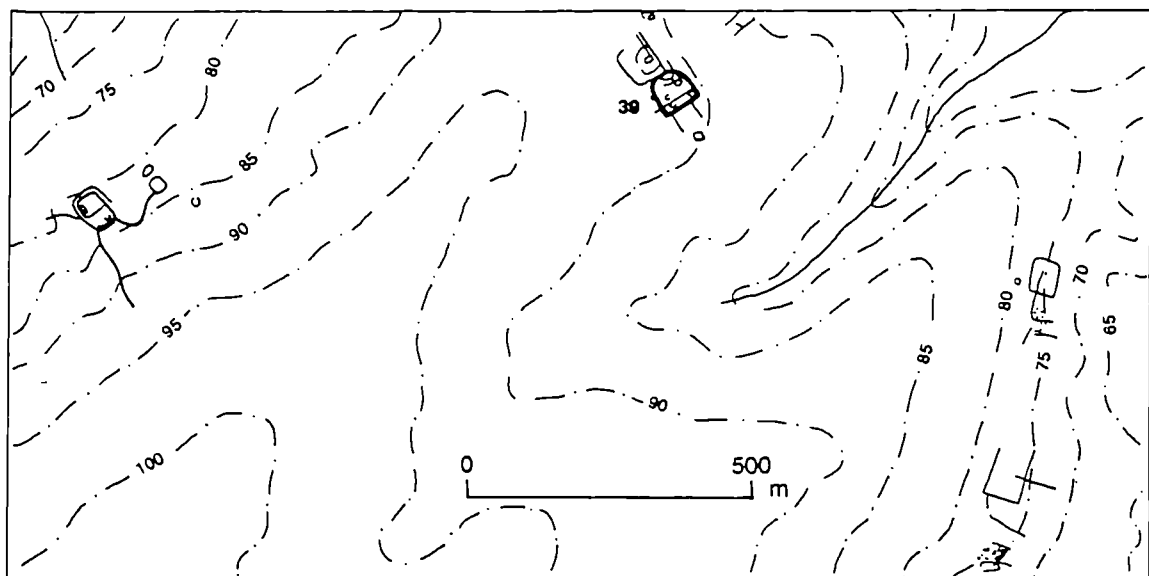

Figure 6.50 Crop marks and excavated evidence around Great Doddington

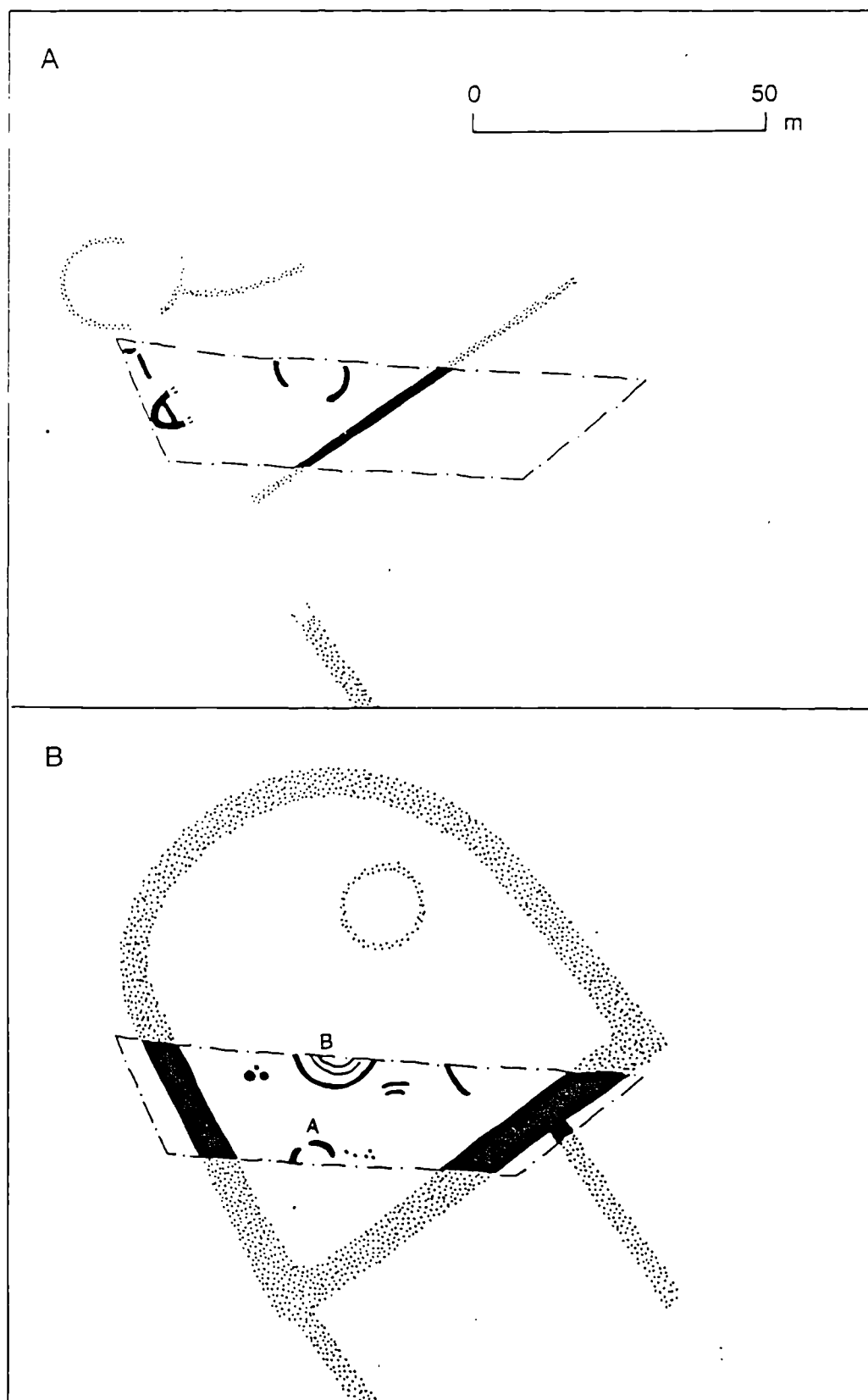

Figure 6.51 Phase 1 (A) and phase 2 (B) features at Great Doddington 39

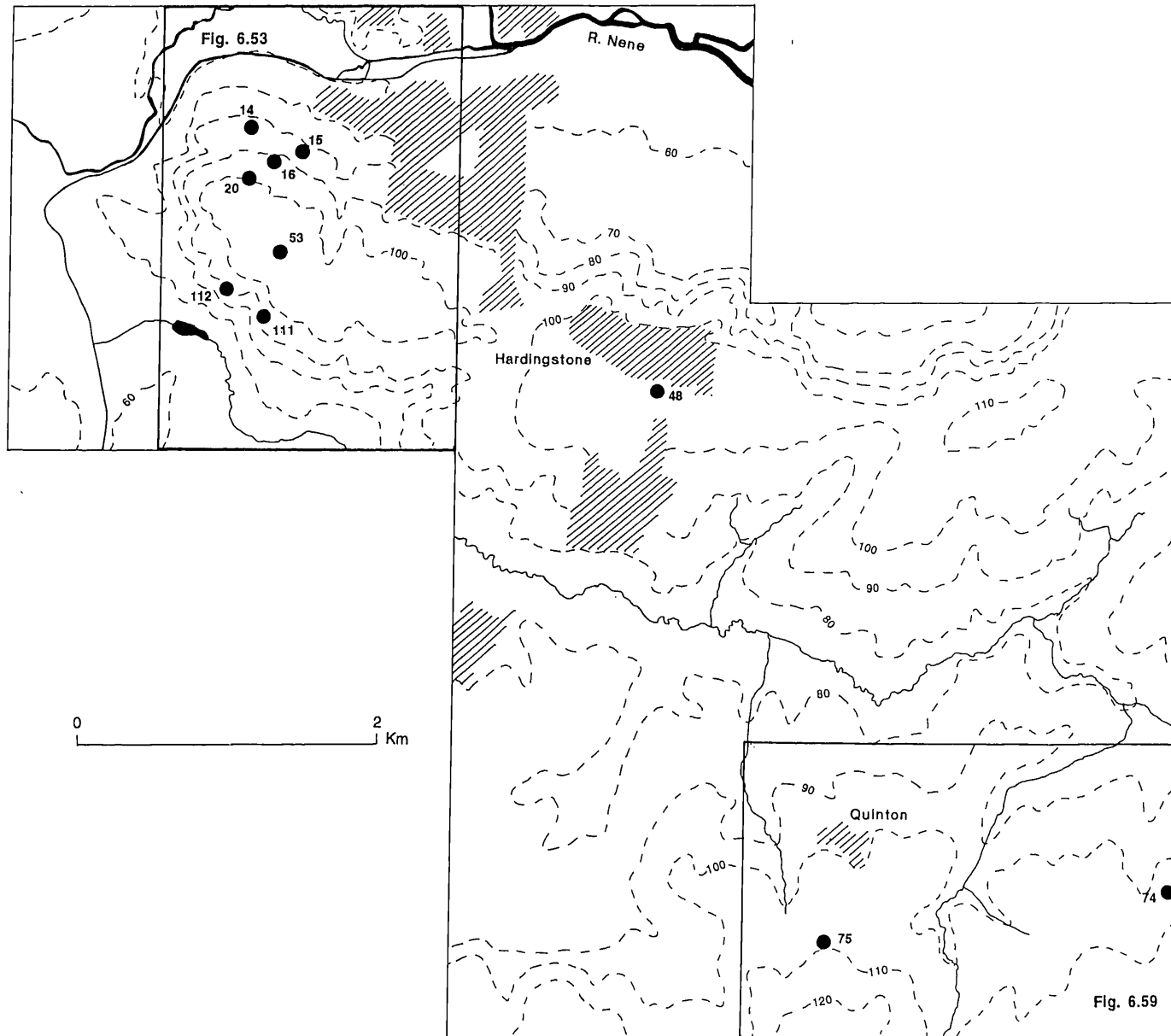

Figure 6.52 Map of the Hunsbury/Quinton case study showing the location of gazetteer sites and the detailed study blocks

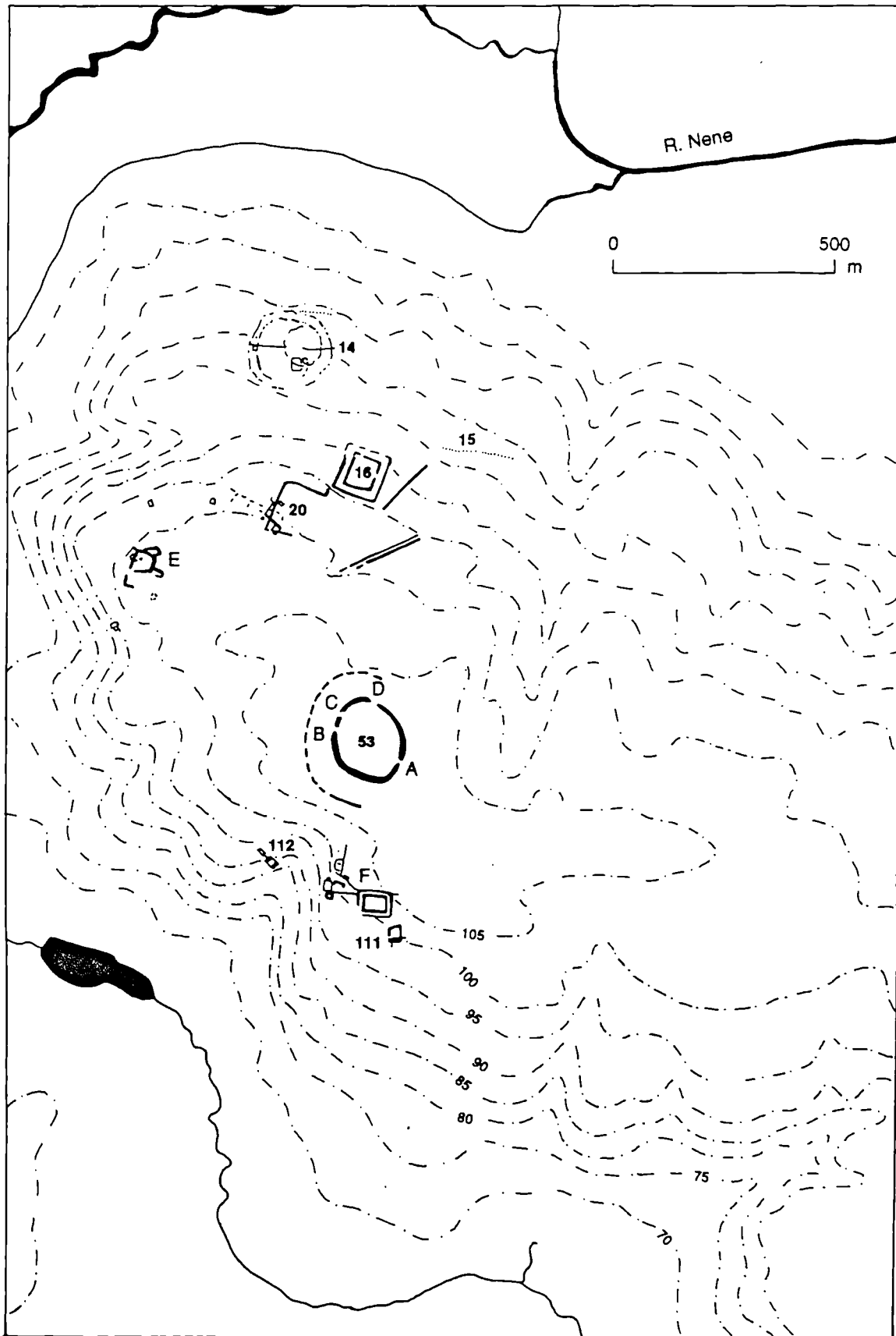

Figure 6.53 Crop marks and excavated evidence around Hunsbury Hill

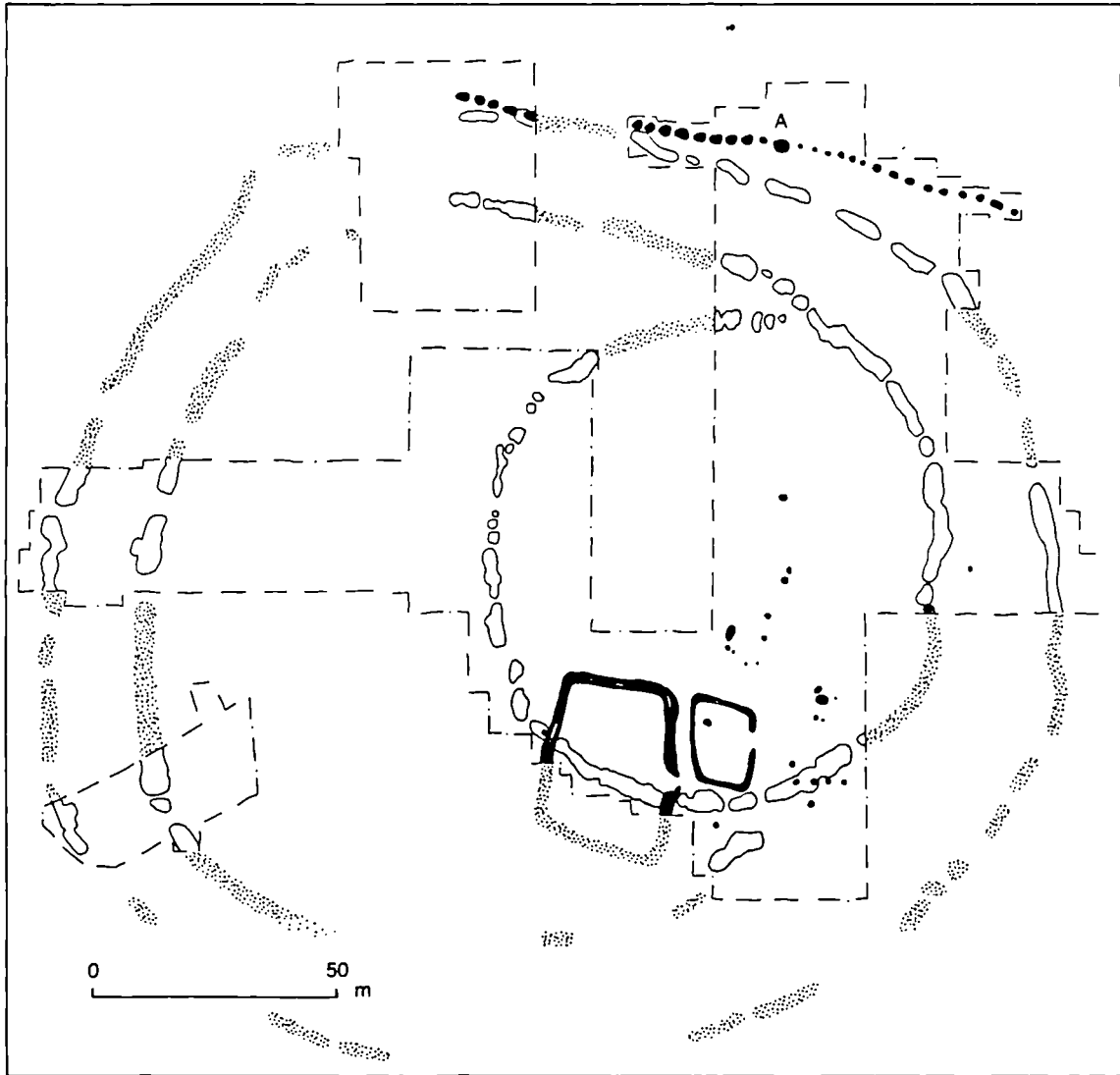

Figure 6.54 Earlier first millennium BC features at Briar Hill 14

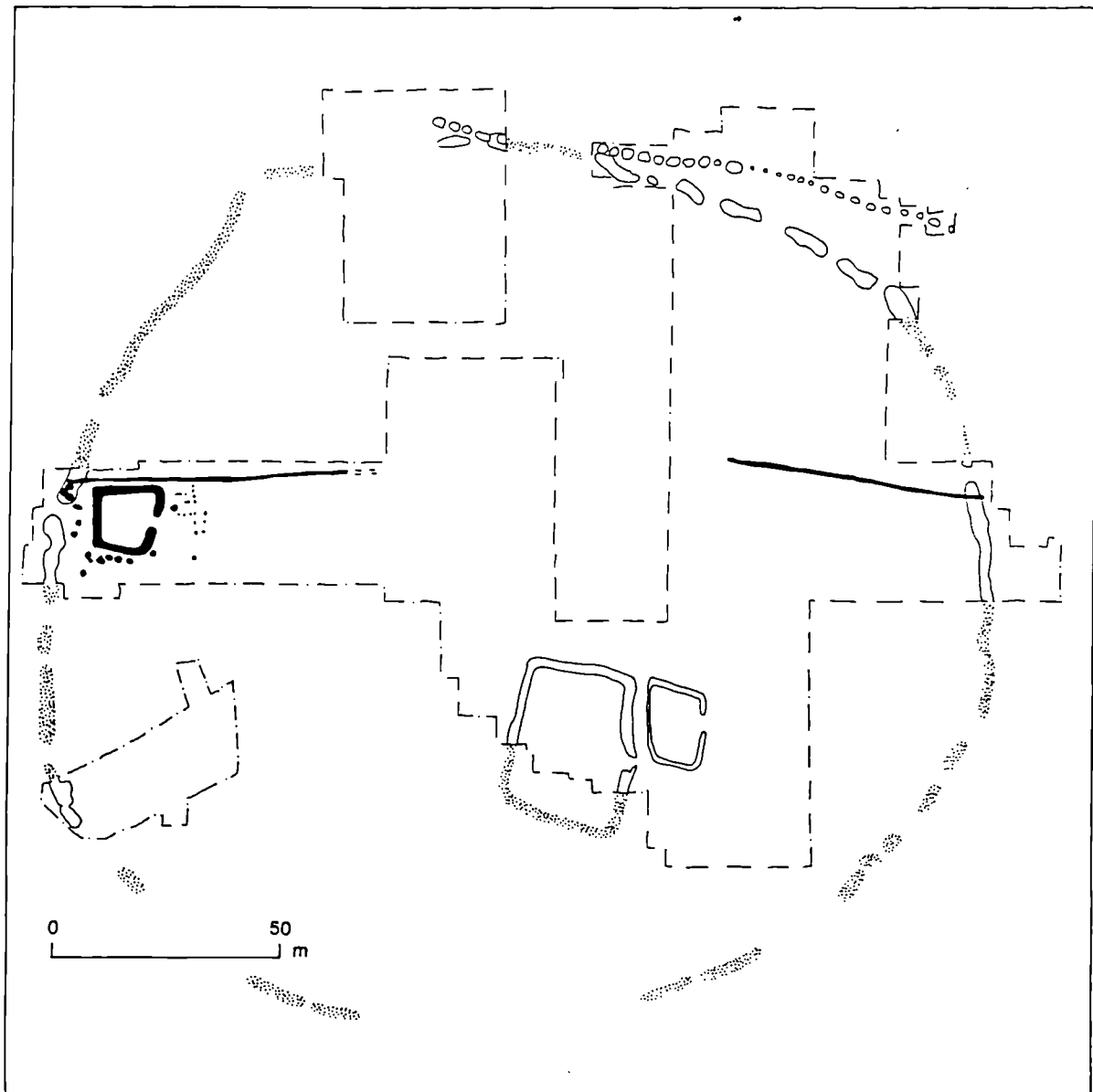

Figure 6.55 Later first millennium BC features at Briar Hill 14

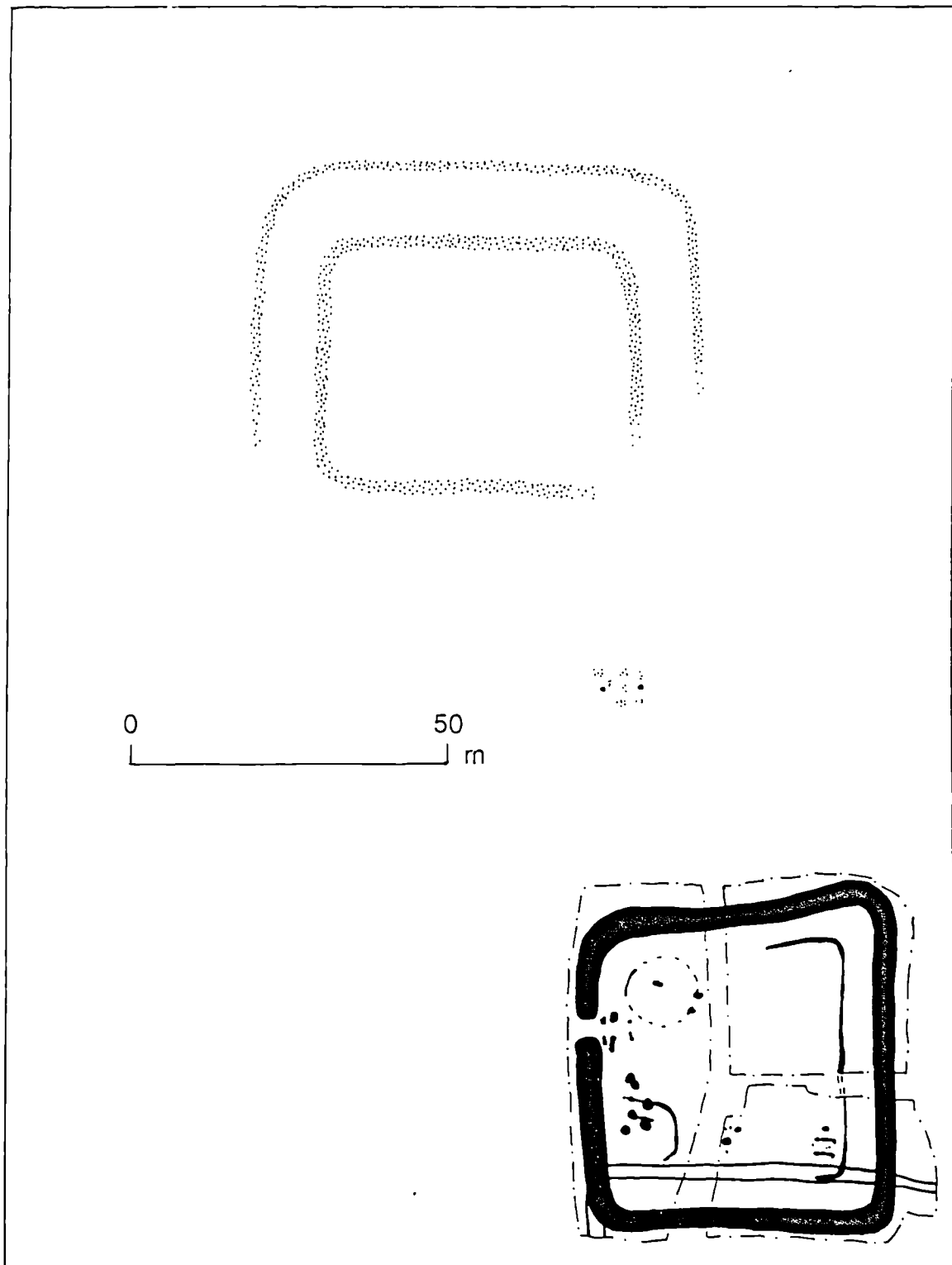

Figure 6.56 Middle iron age features at Wootton Hill Farm 111

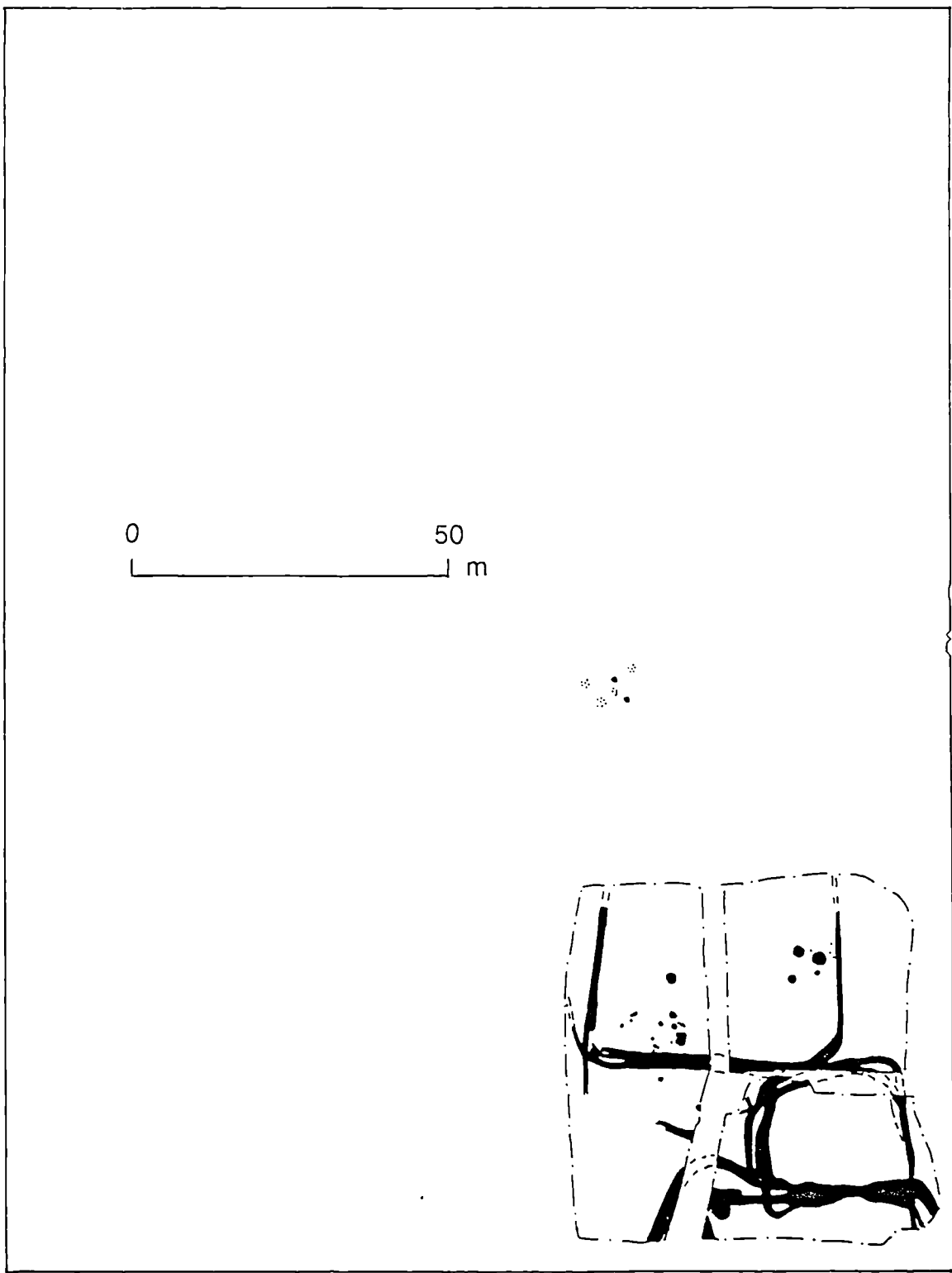

Figure 6.57 Late iron age features at Wootton Hill Farm 111

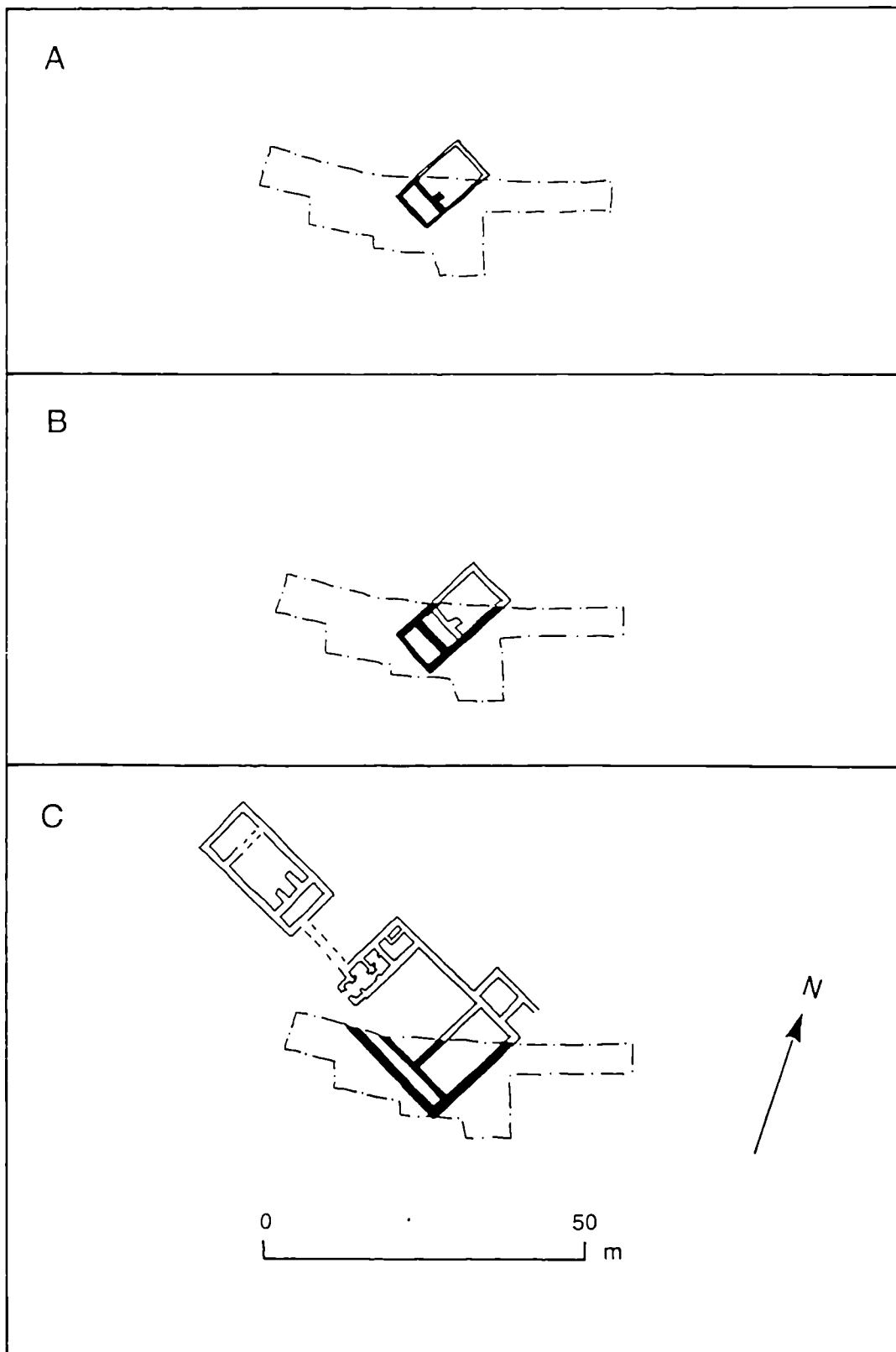

Figure 6.58 Phase plans of the Roman buildings at Wootton 112

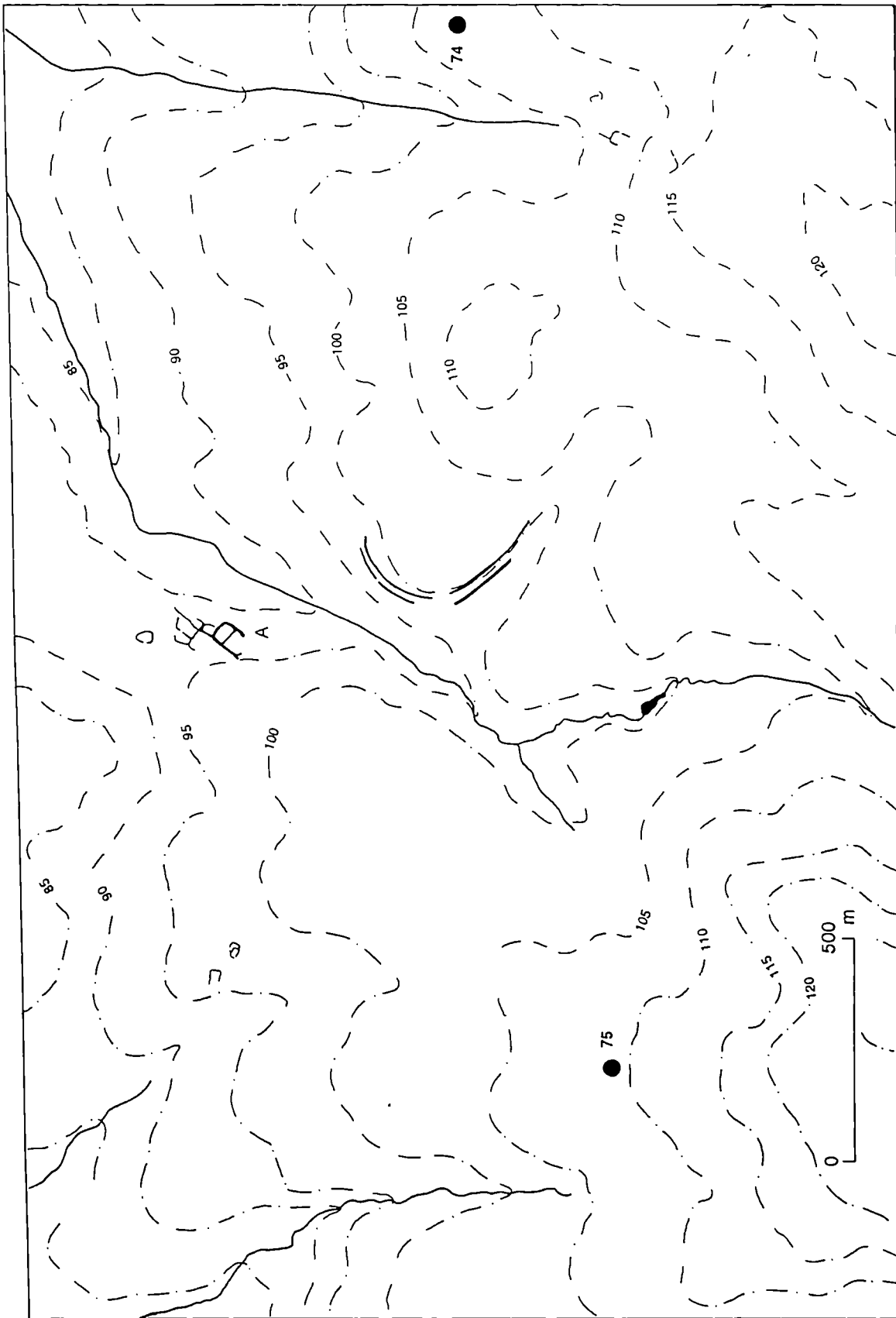

Figure 6.59 Crop marks and excavated evidence around Quinton

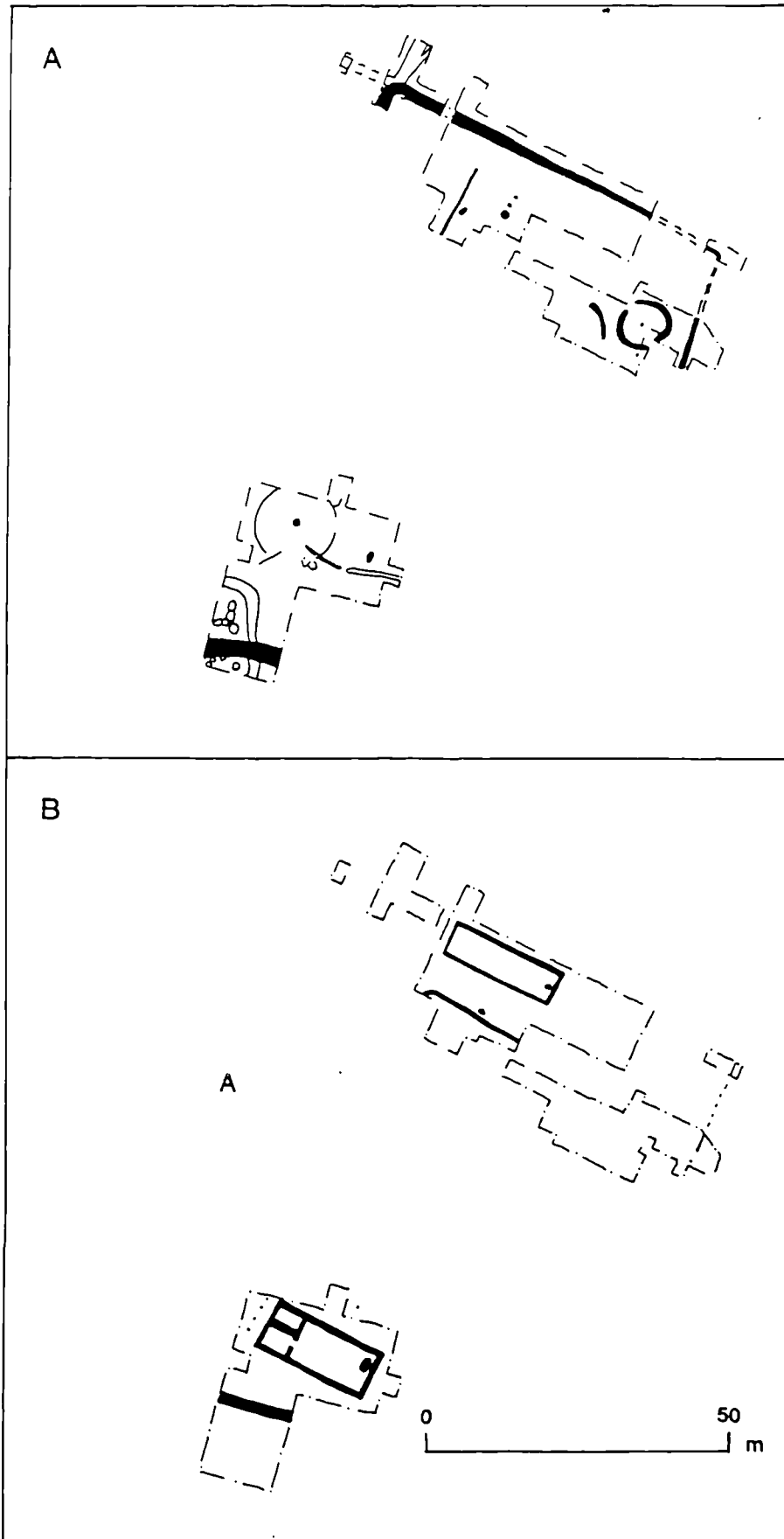

Figure 6.60 Iron age (A) and Roman (B) features at Quinton 74

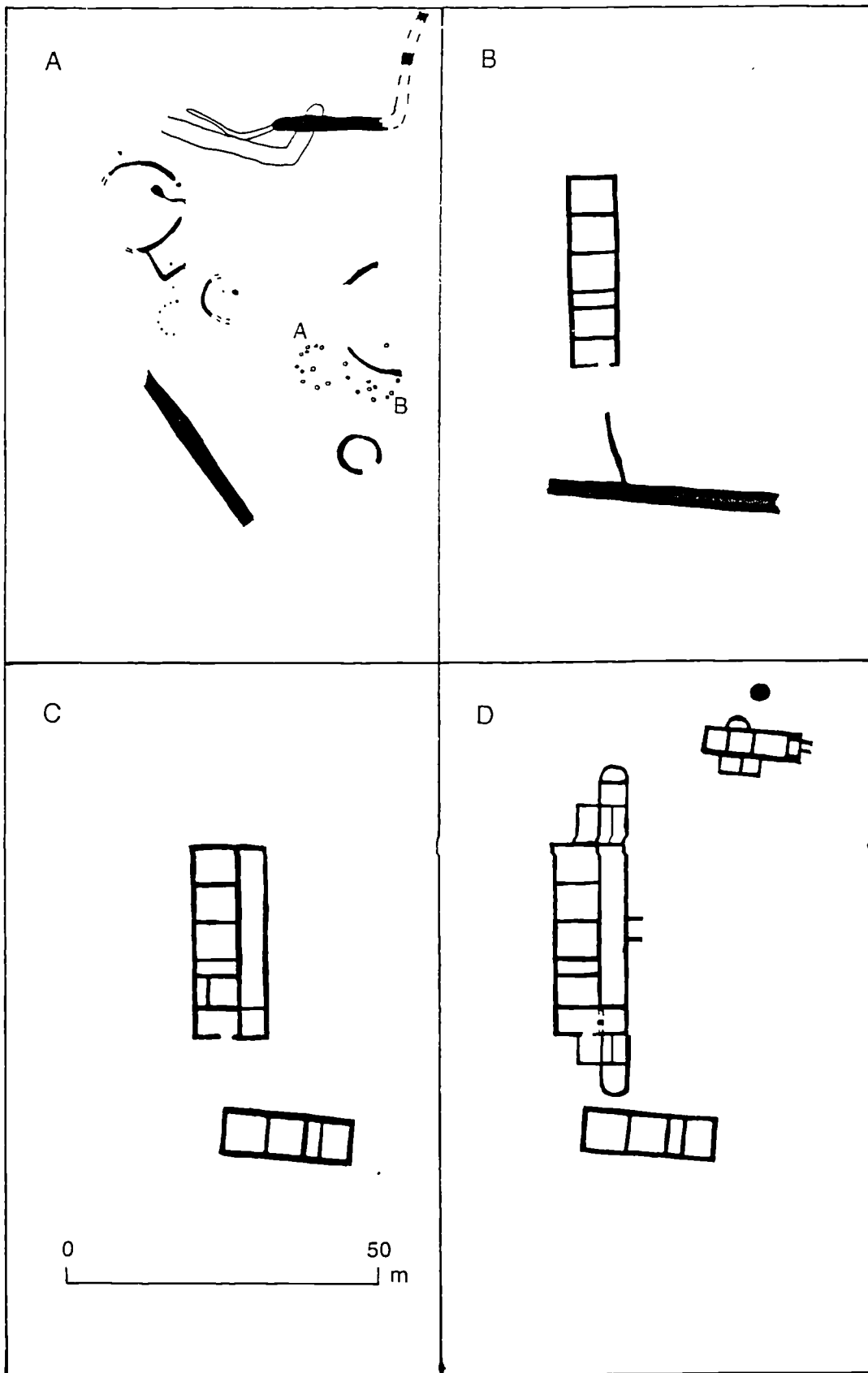

Figure 6.61 Earlier phase plans of the features at Piddington 75

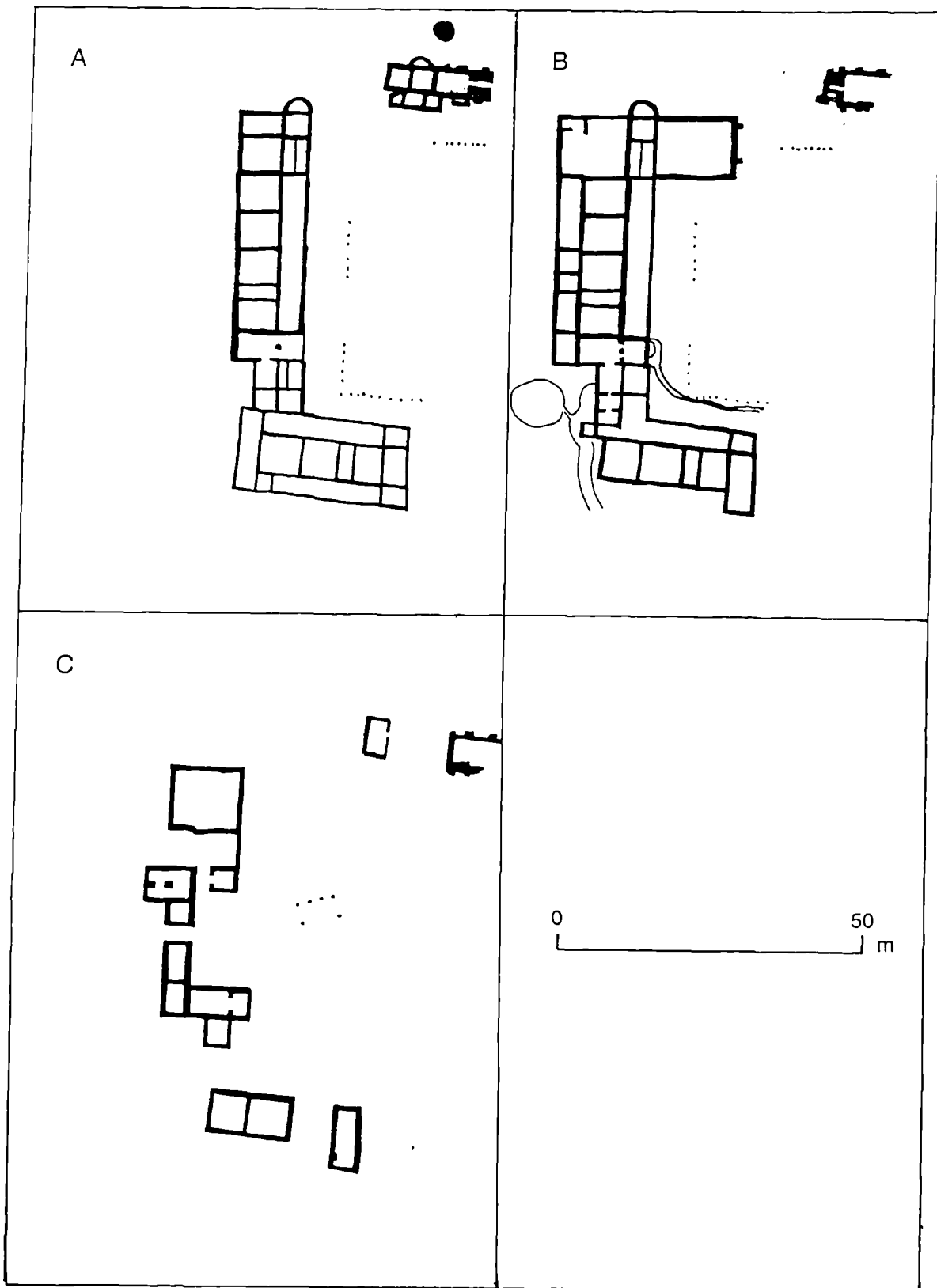

Figure 6.62 Later phase plans of the features at Piddington 75

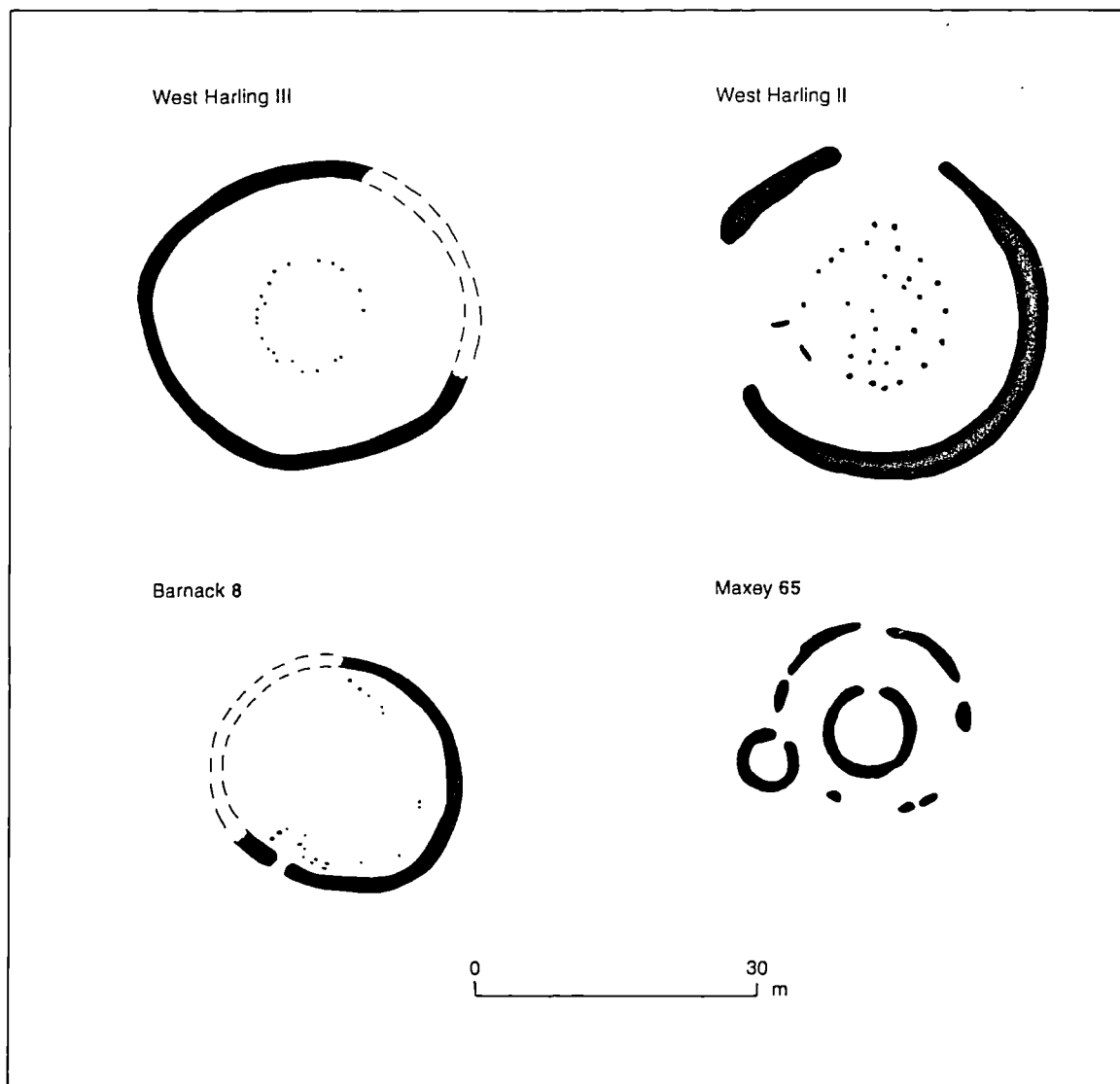

Figure 6.63 The Barnack 8 and Maxey 65 enclosures compared to the early iron age examples from West Harling, Norfolk

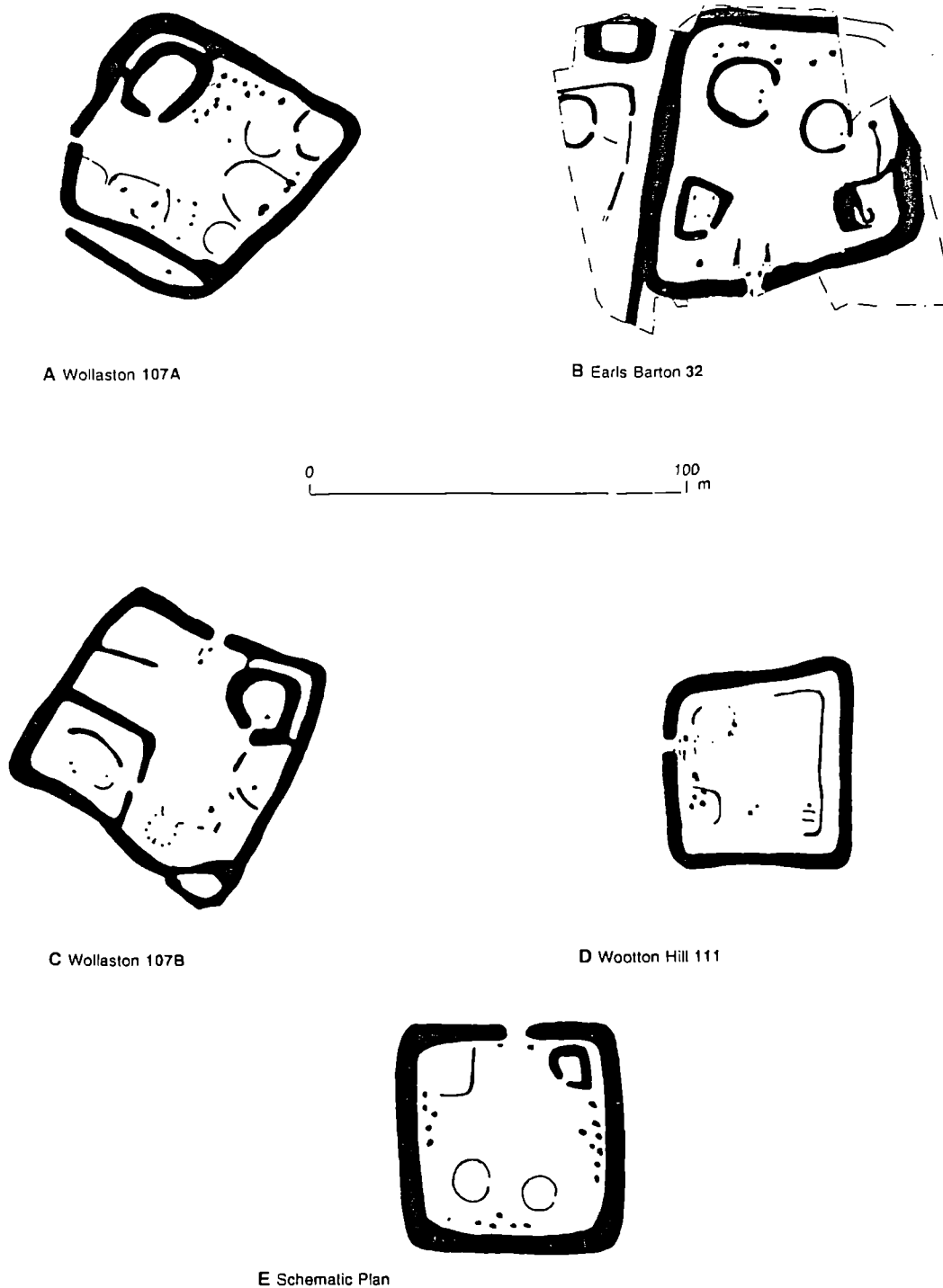

Figure 6.64 The Wollaston 107, Earls Barton 32 and Wootton Hill 111 enclosures and a schematic plan (E) suggesting their basic spatial organisation

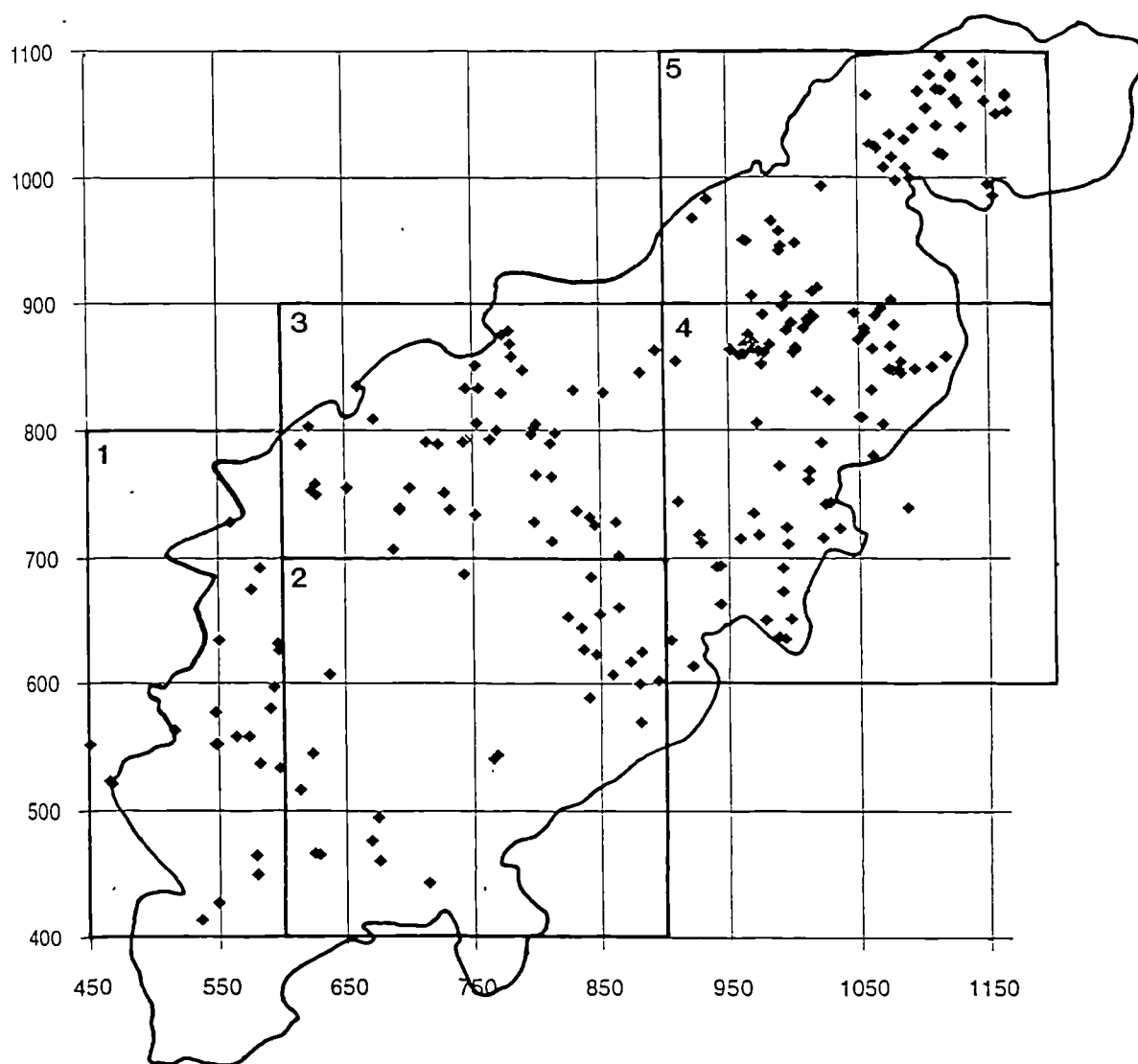

Figure 7.1 Distribution map of the pottery scatters recovered by David Hall showing the five sample blocks chosen for comparative purposes in section 7.6

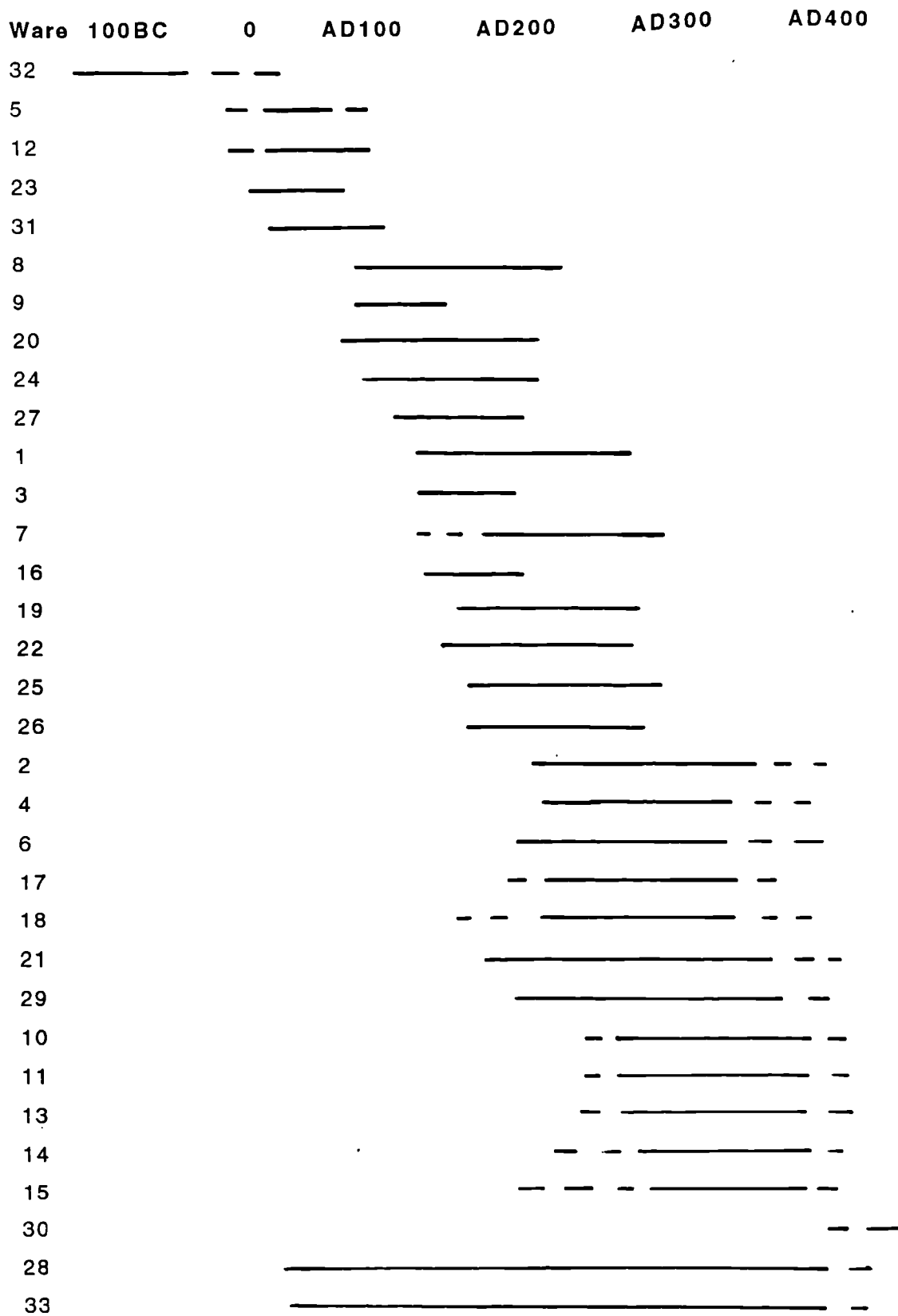

Figure 7.2 Cascade diagram showing the date ranges assigned to each of the 33 fabric groups analysed

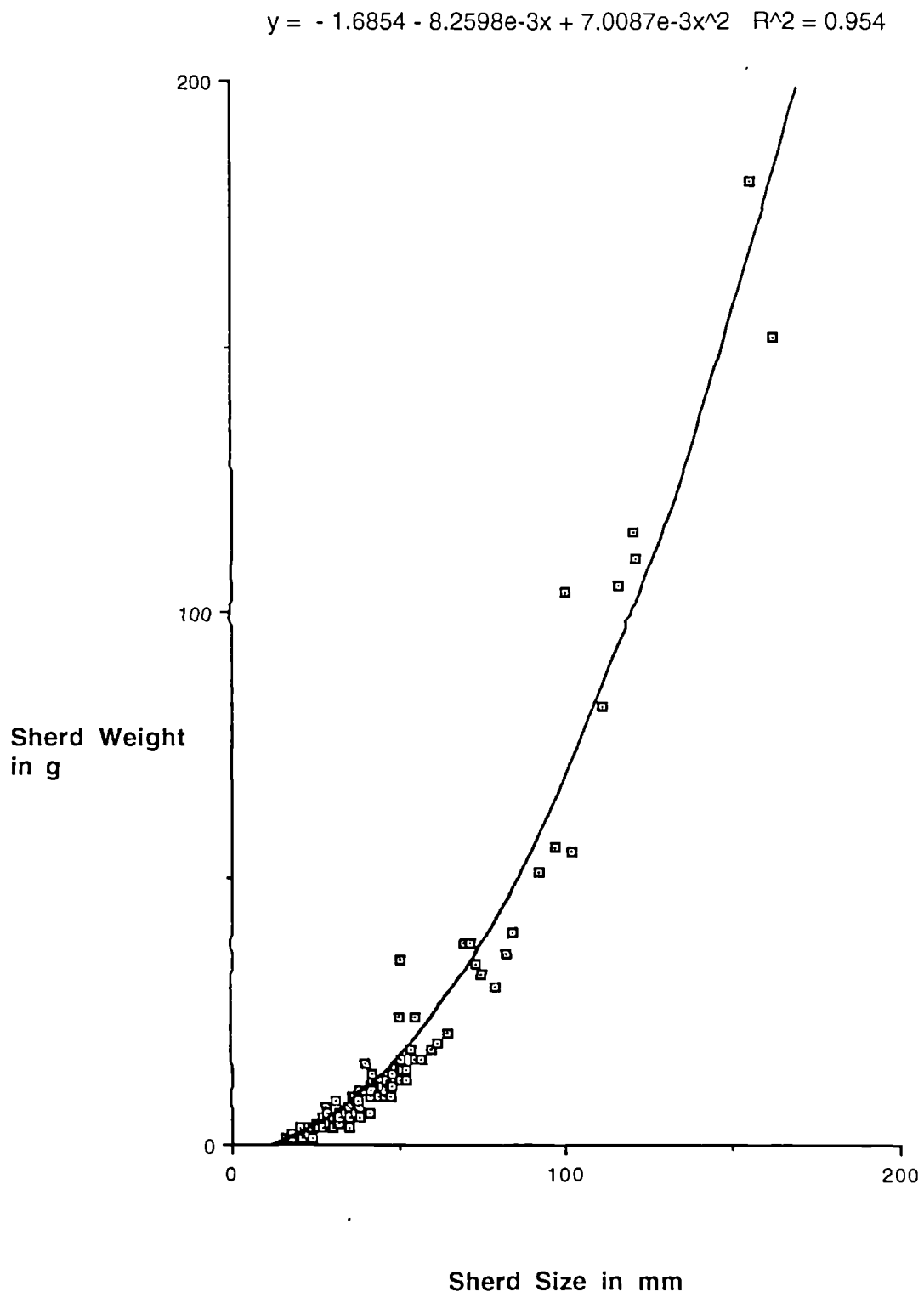

Figure 7.3 Regression analysis for the correlation between sherd size and weight for fabric 3.1

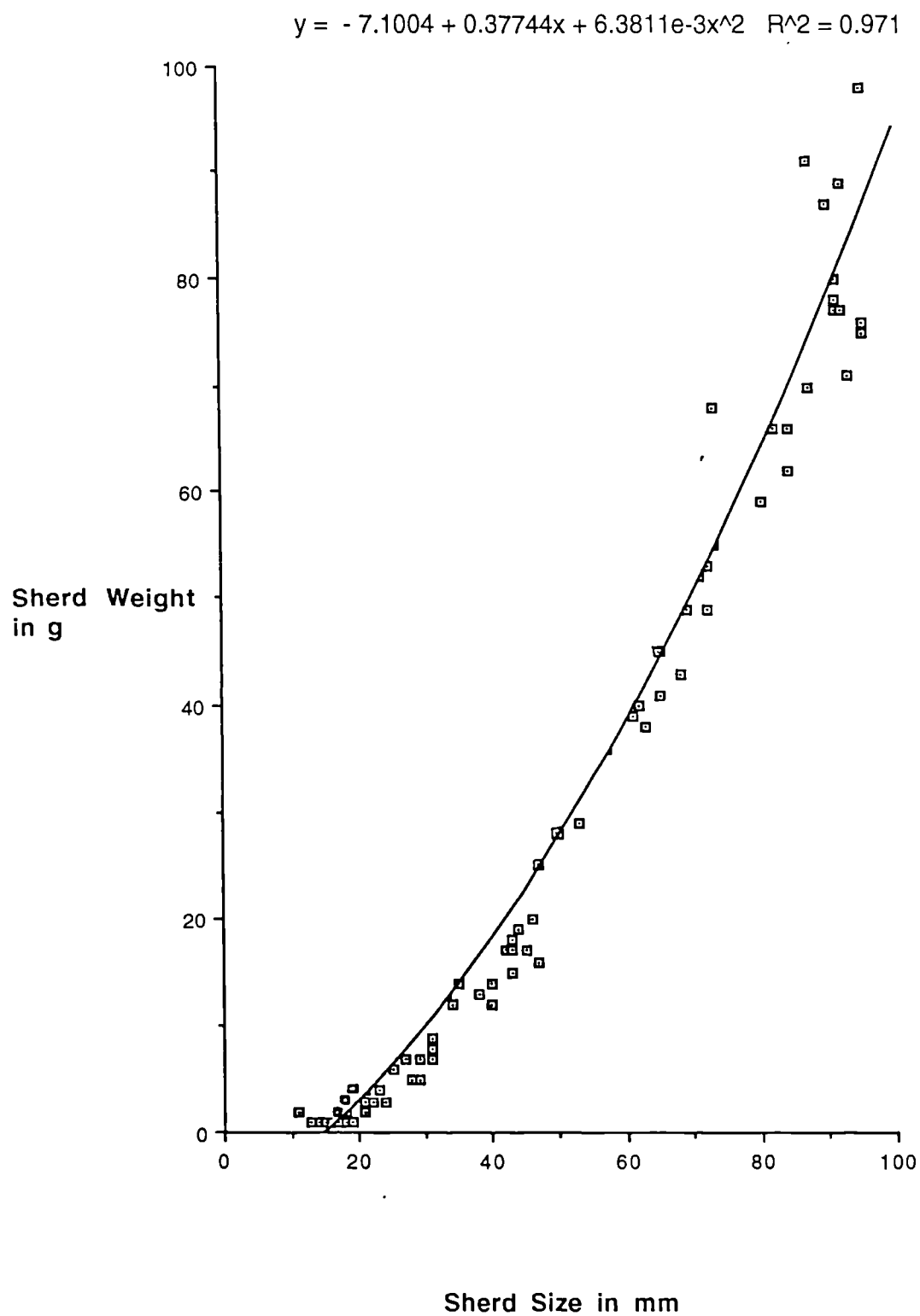

Figure 7.4 Regression analysis for the correlation between sherd size and weight for fabric 4.2

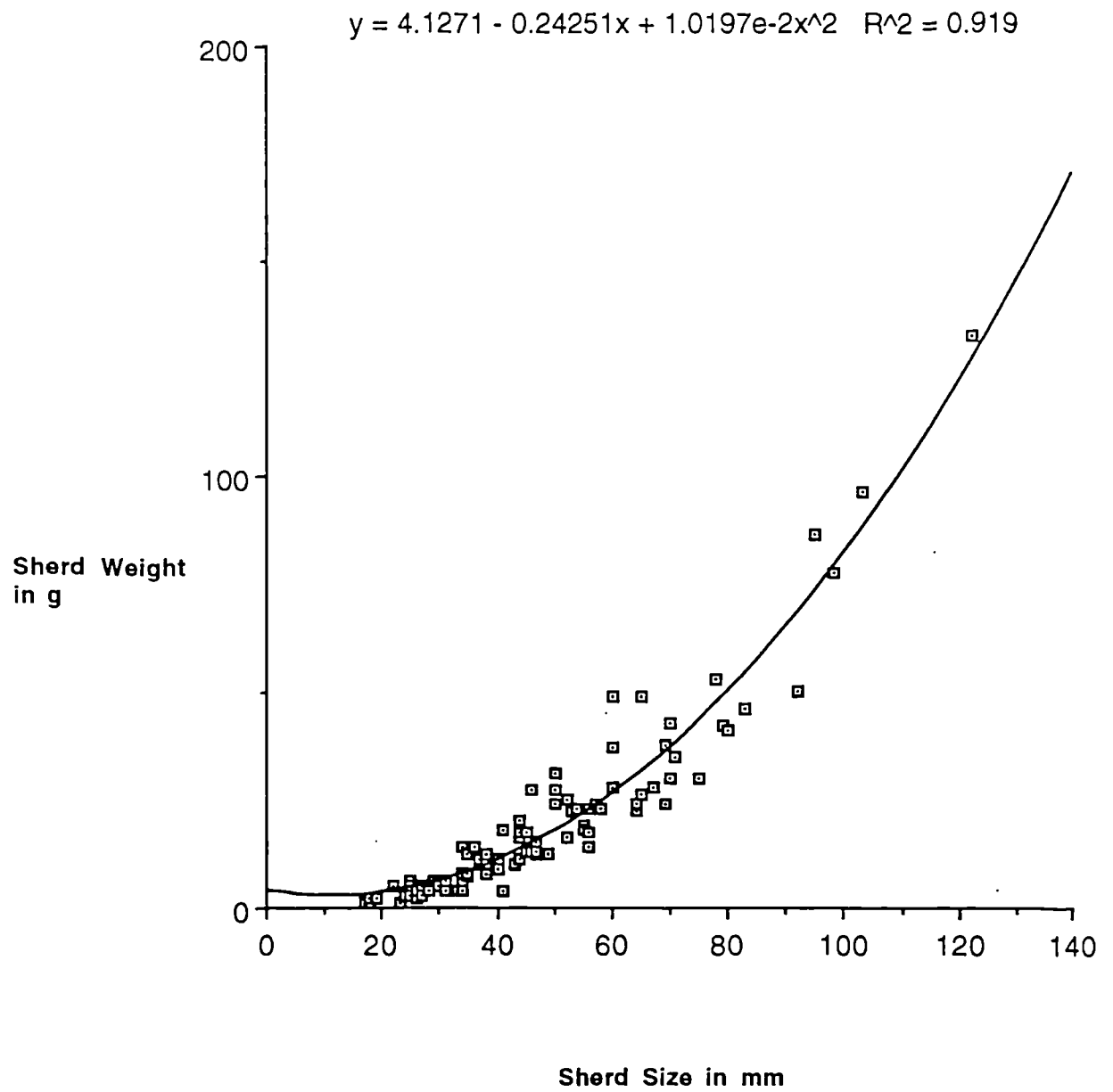

Figure 7.5 Regression analysis for the correlation between sherd size and weight for fabric 9

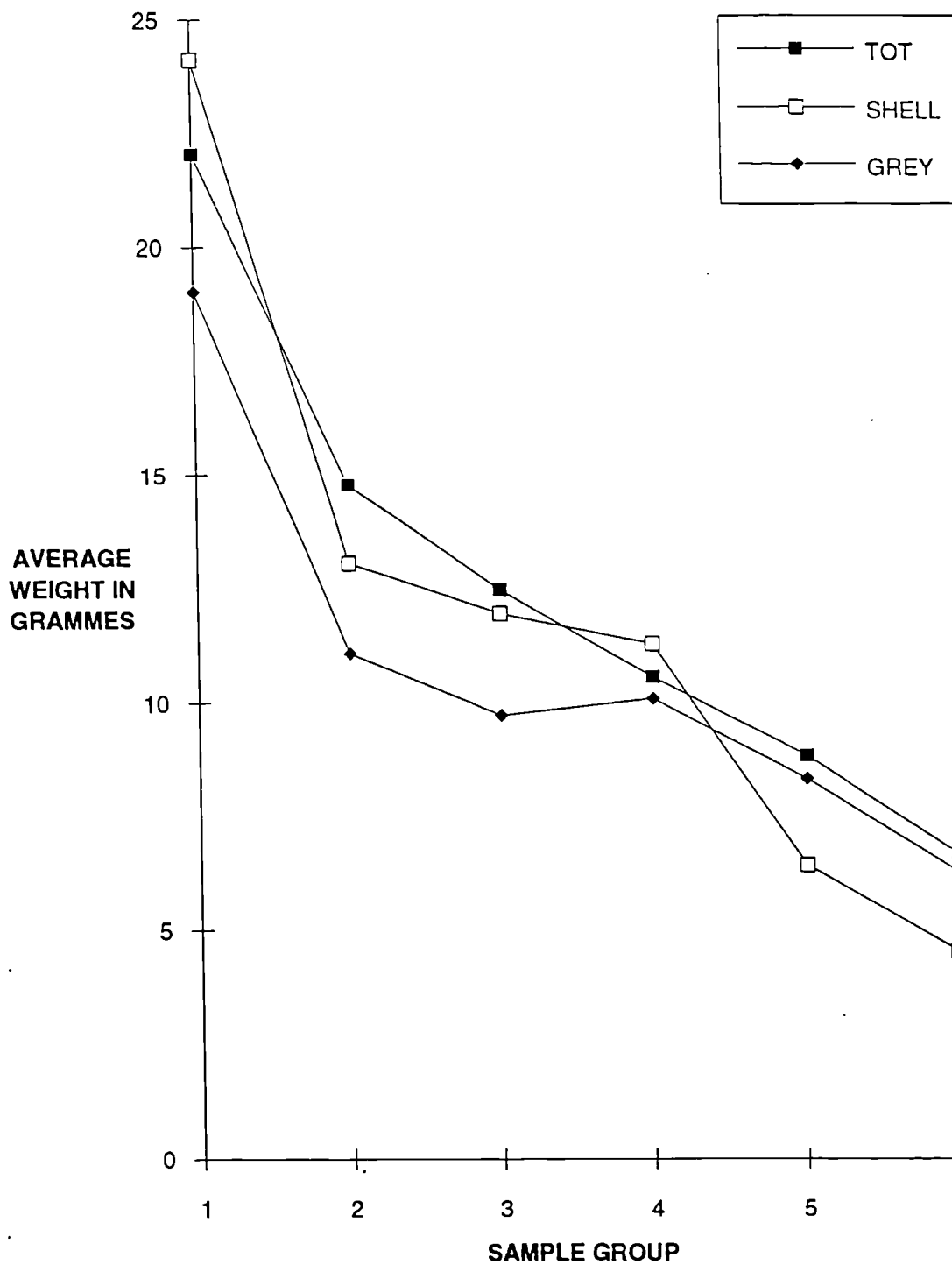

Figure 7.6 The average sherd weights for all fabrics, fabric 3.1 (shell) and fabric 4.2 (grey) of six sample groups of assemblages from the survey

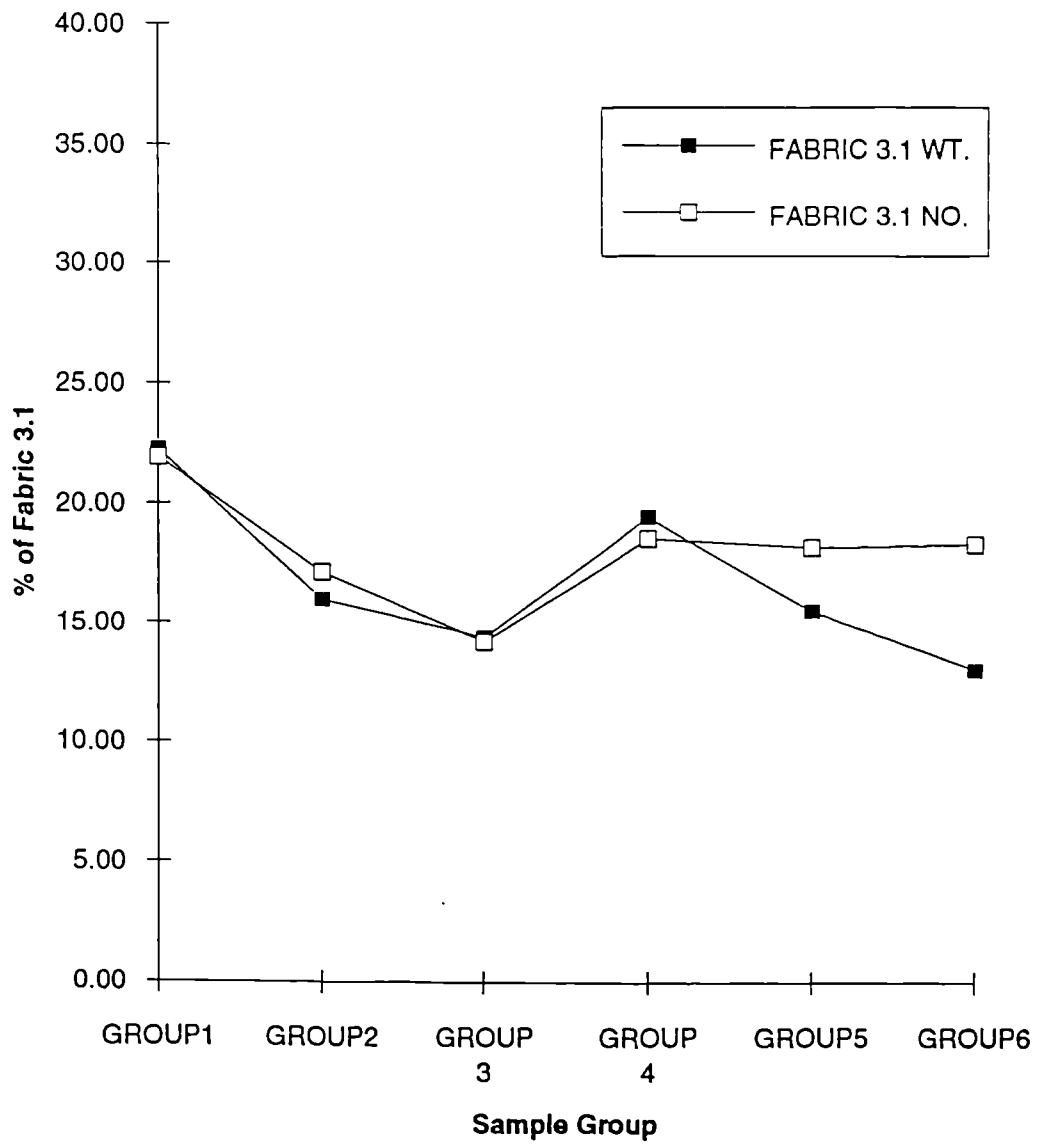

Figure 7.7 The relative proportion of fabric 3.1 in the six groups of assemblages when recorded by sherd weight and sherd count

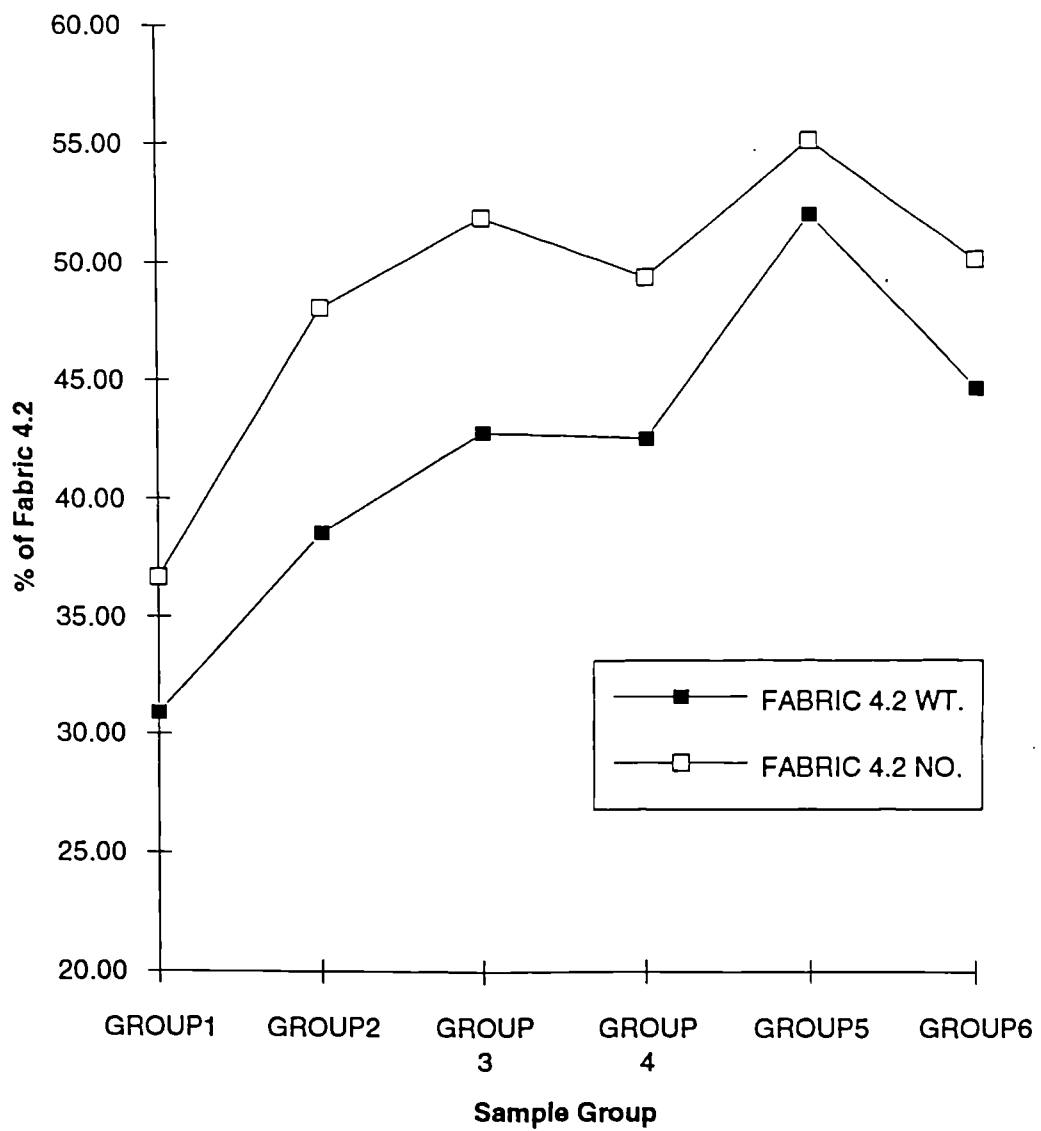

Figure 7.8 The relative proportion of fabric 4.2 in the six groups of assemblages when recorded by sherd weight and sherd count

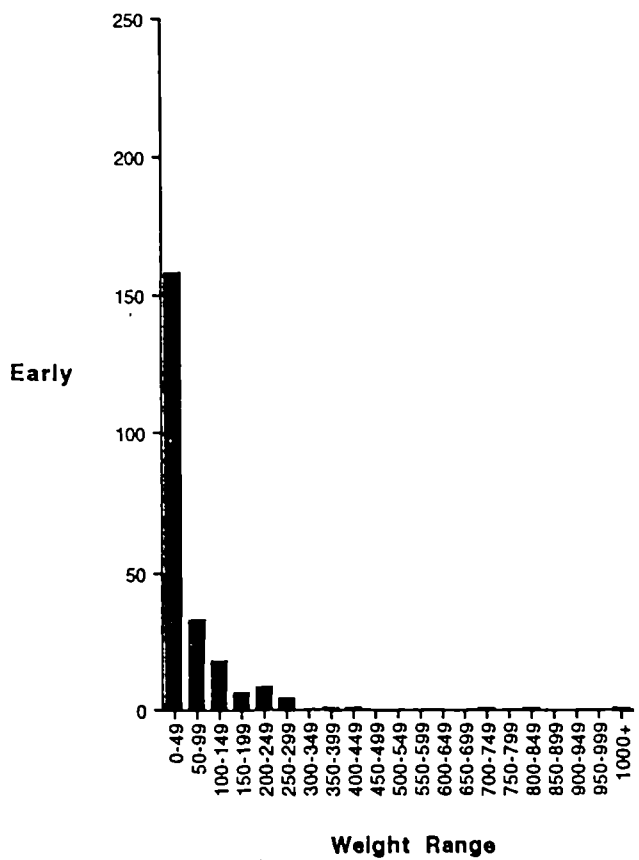
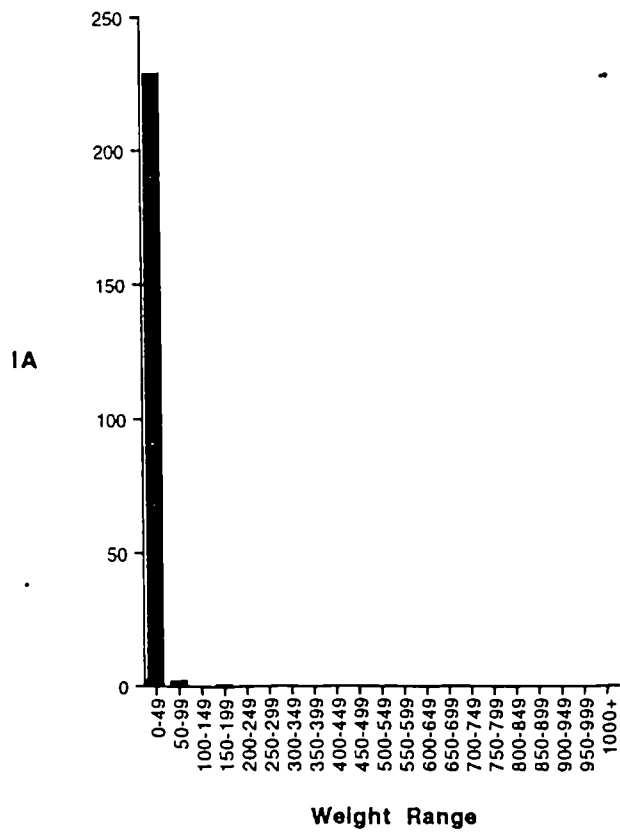

Figure 7.9 A simplified frequency distribution of the weight of pottery present in assemblages in the a) Iron Age and b) Early periods

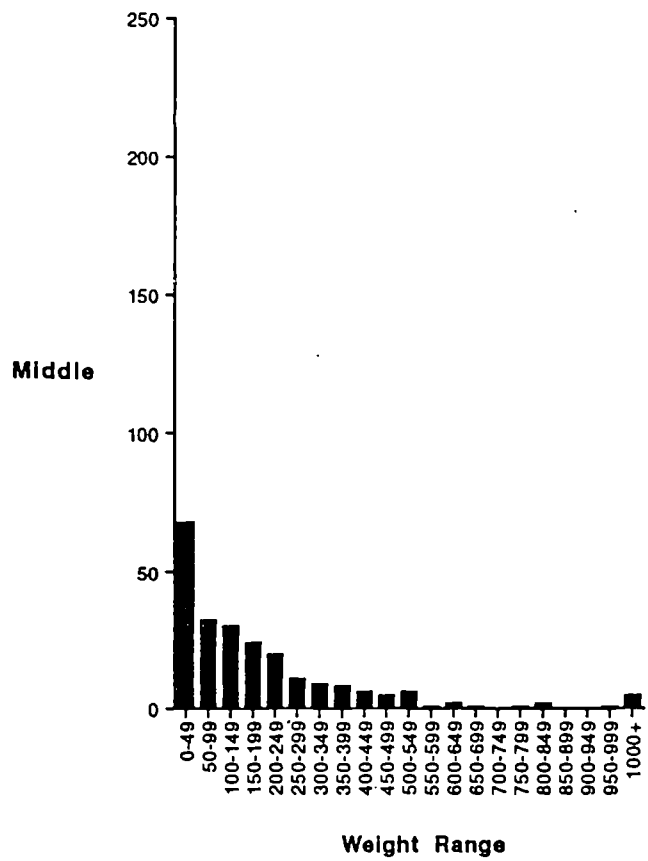
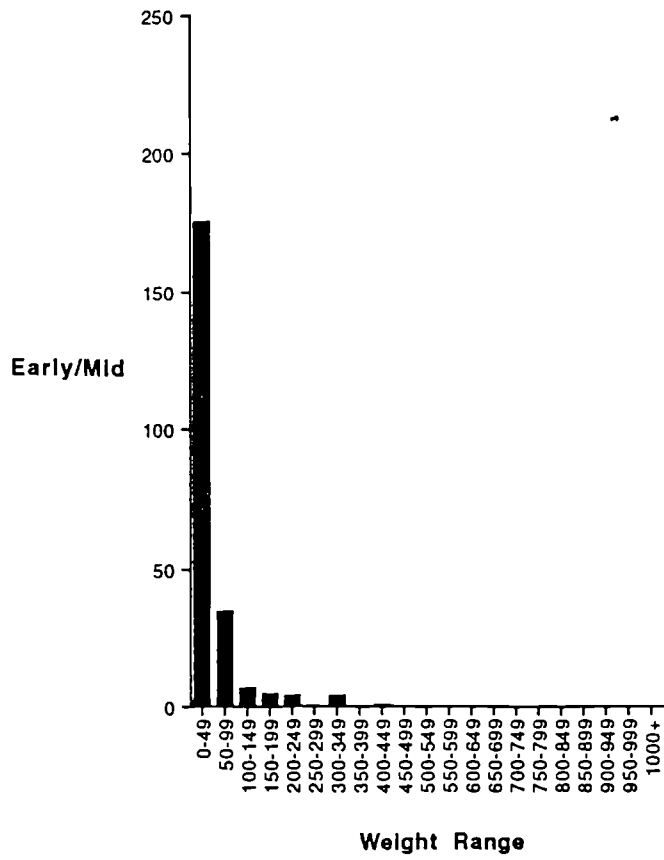

Figure 7.10 A simplified frequency distribution of the weight of pottery present in assemblages in the a) Early/Mid and b) Middle periods

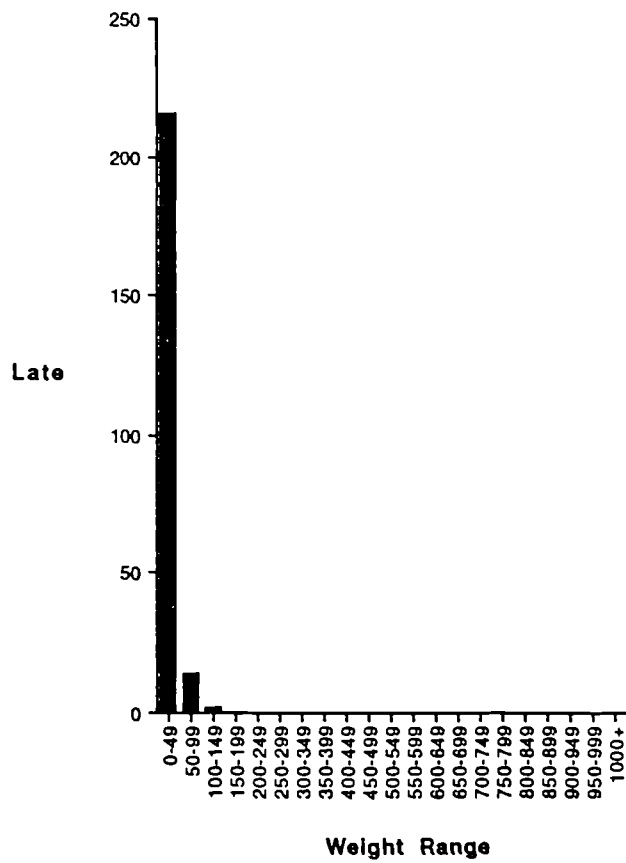
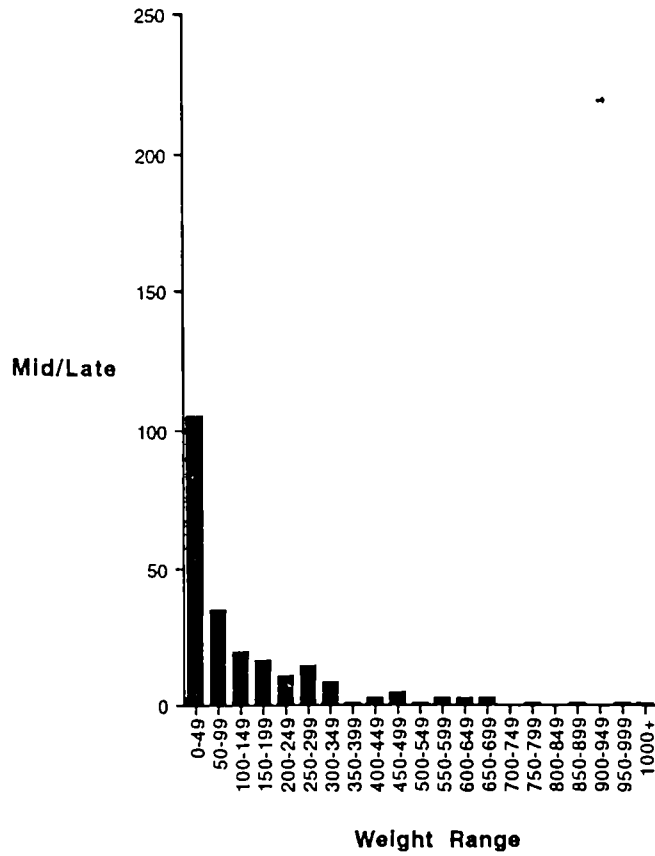

Figure 7.11 A simplified frequency distribution of the weight of pottery present in assemblages in the a) Mid/Late and b) Late periods

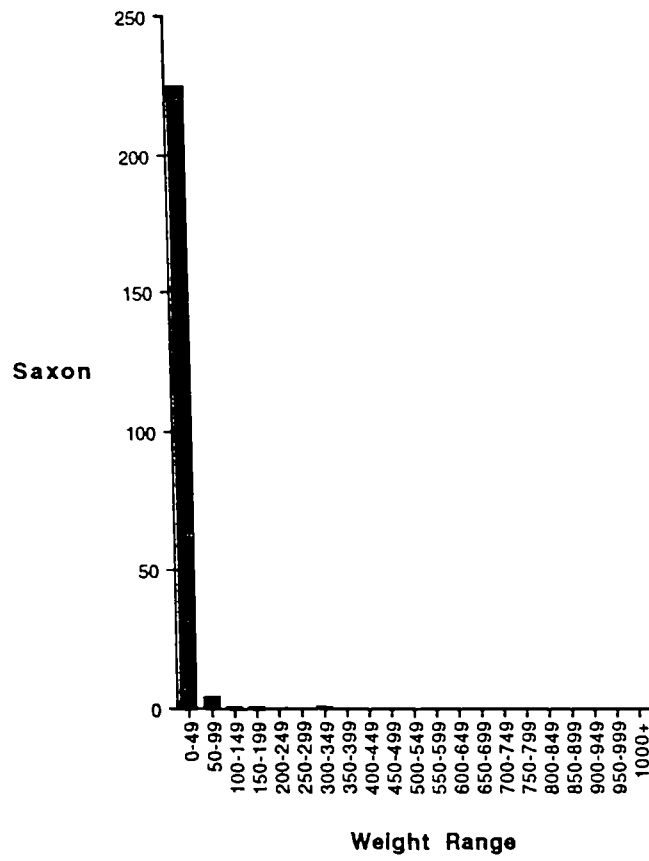

Figure 7.12 A simplified frequency distribution of the weight of pottery present in the Saxon period

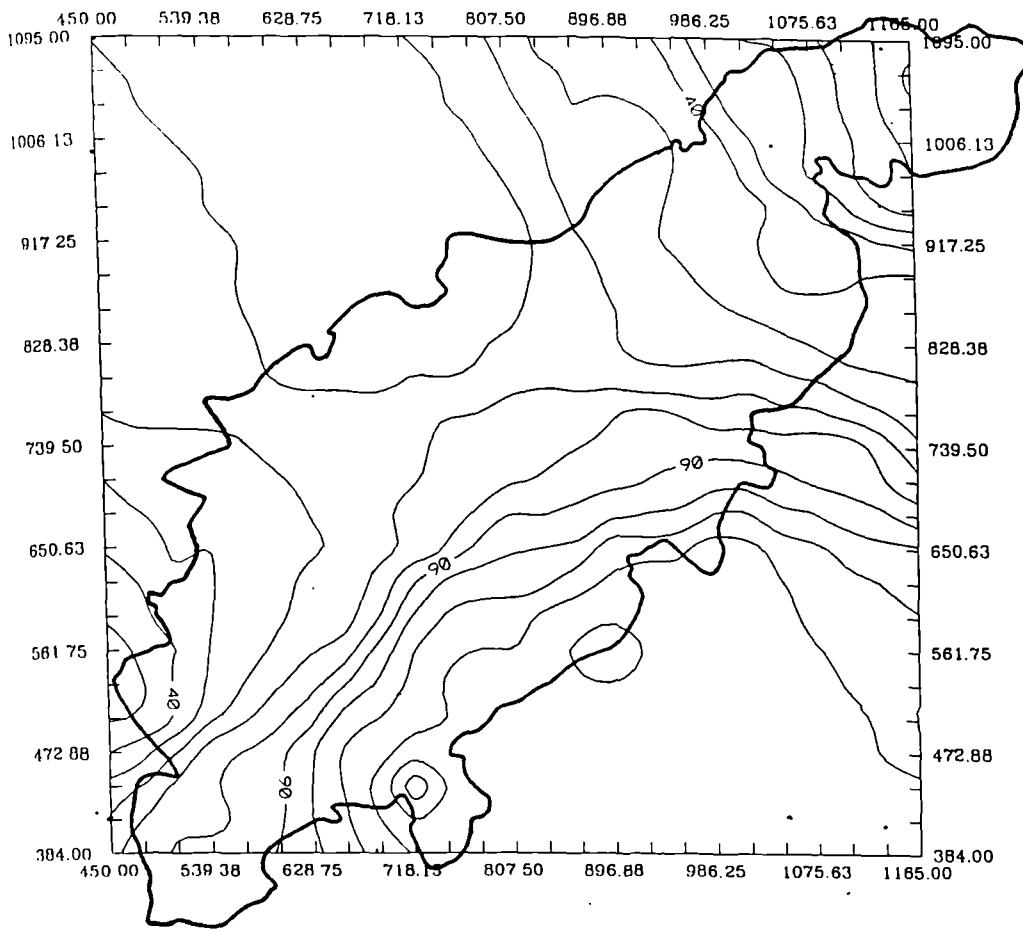

Figure 7.13 Trend surface for Early period pottery across the region

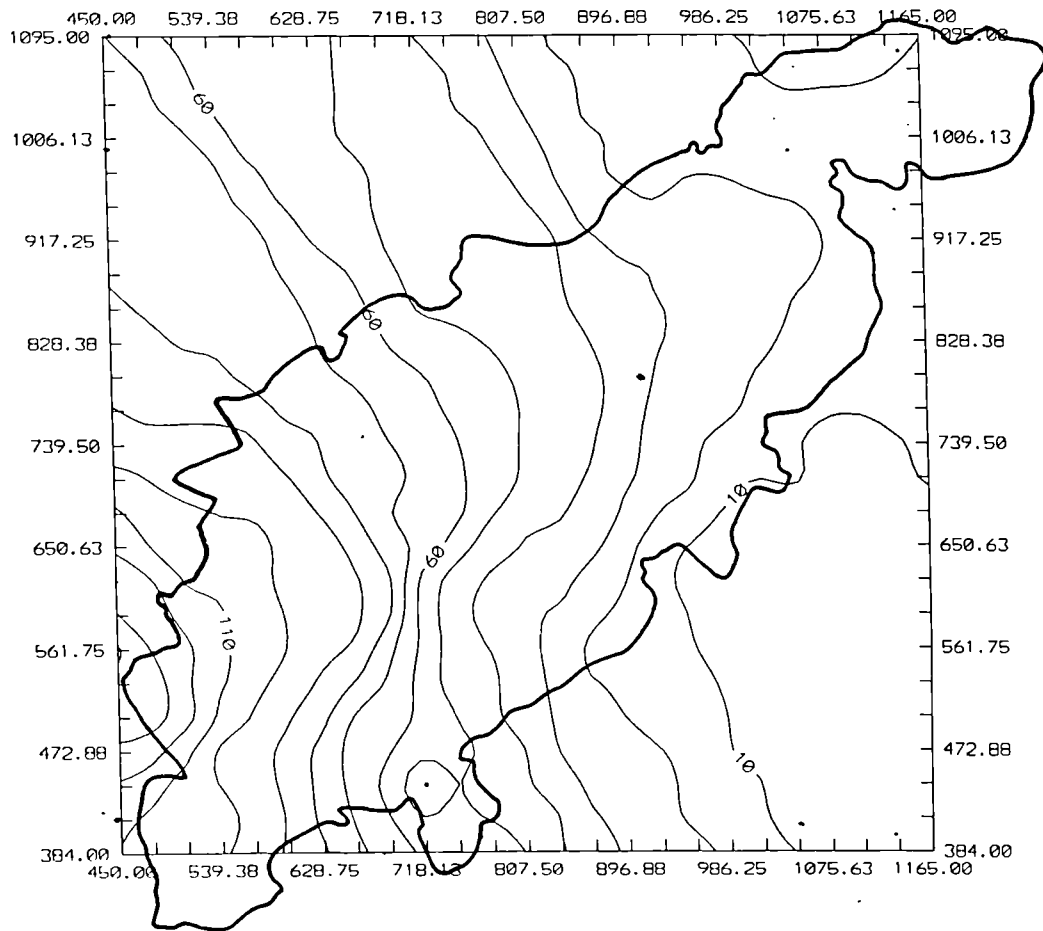

Figure 7.14 Trend surface for Early/Mid period pottery across the region

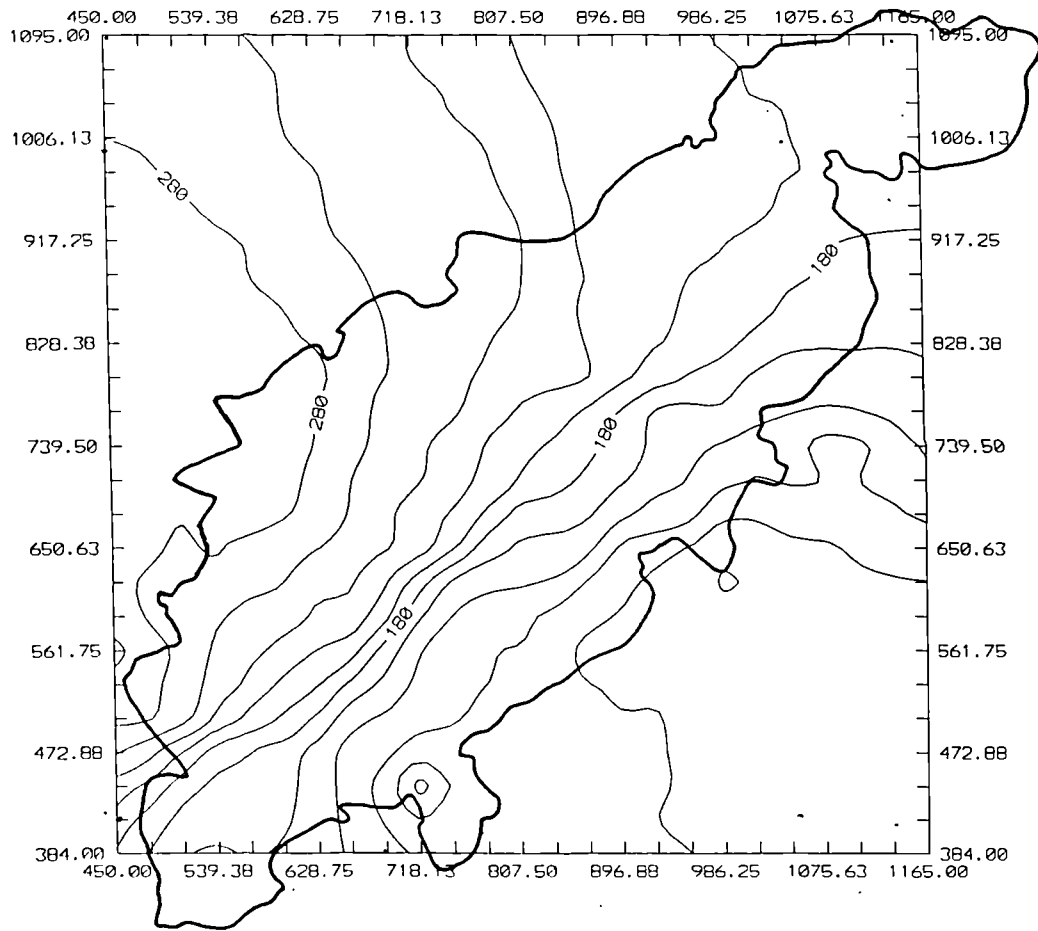

Figure 7.15 Trend surface for Middle period pottery across the region

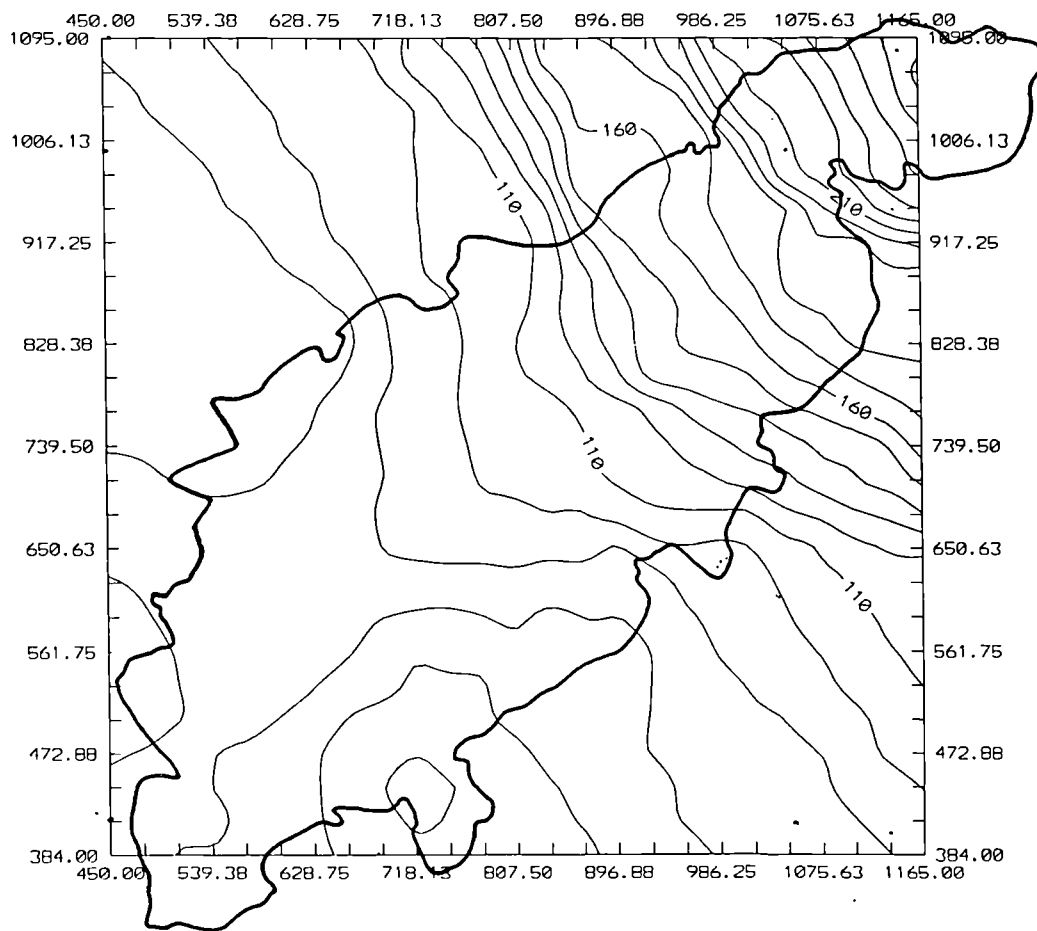

Figure 7.16 Trend surface for Mid/Late period pottery across the region

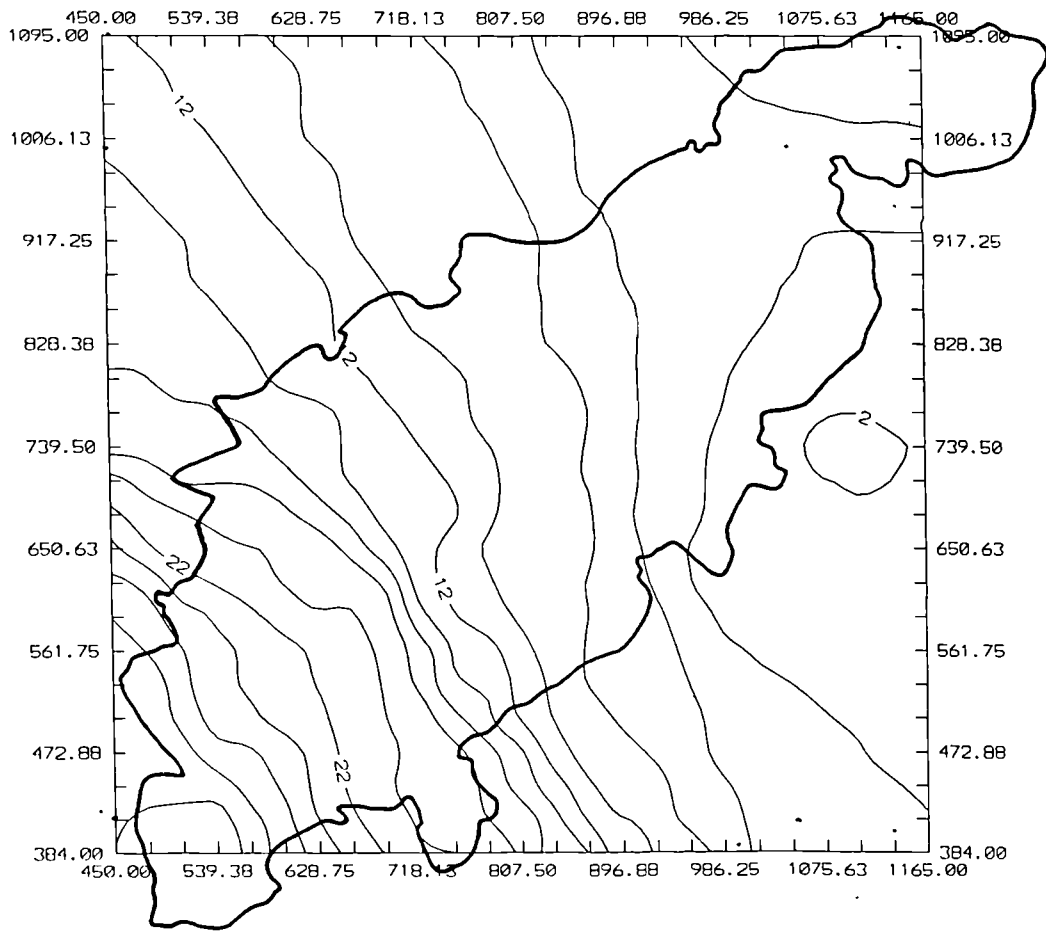

Figure 7.17 Trend surface for Late period pottery across the region

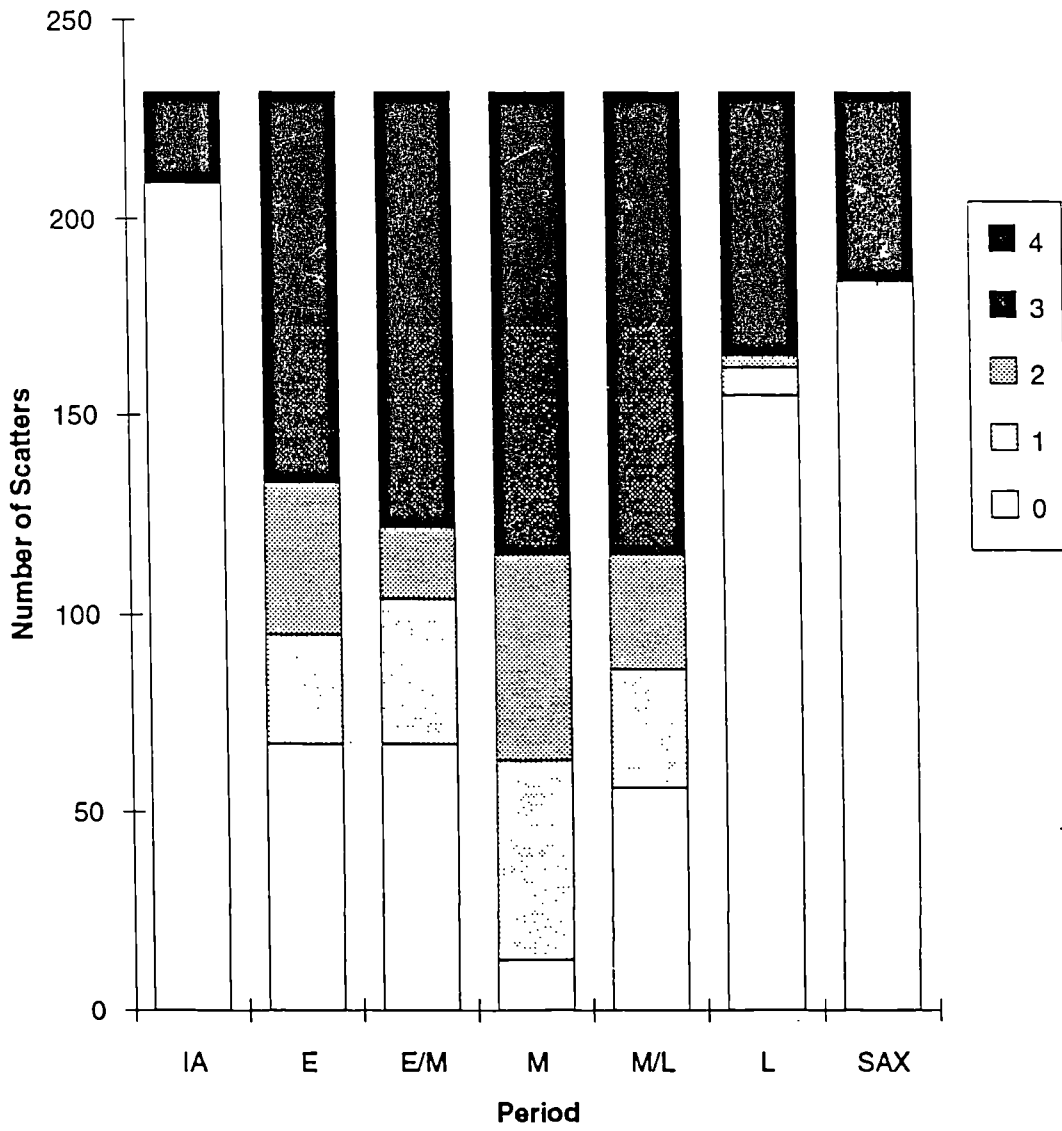

Figure 7.18 The numbers of scatters within each quartile scale through time

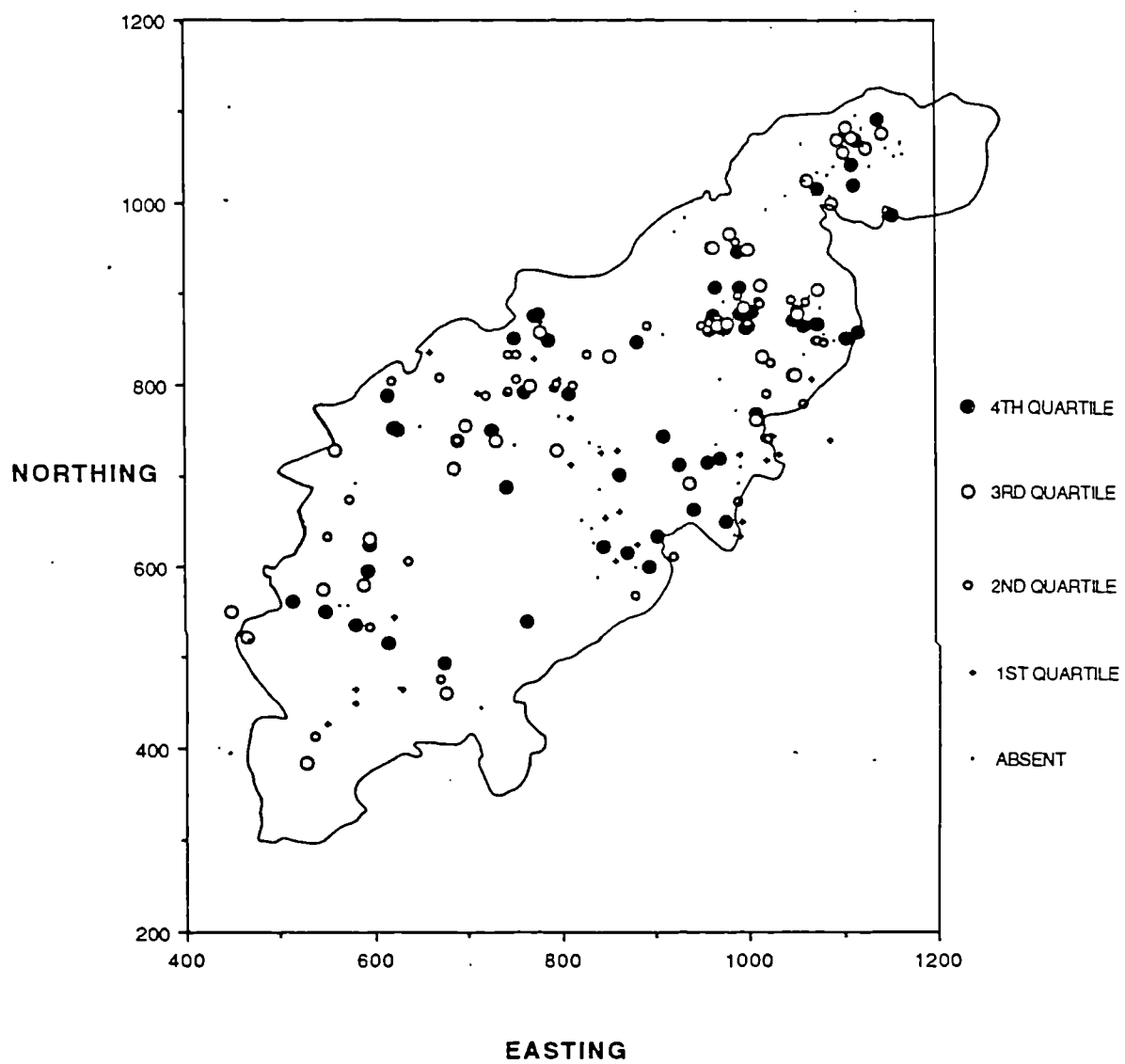

Figure 7.19 Distribution map of all Early scatters by residual quartile

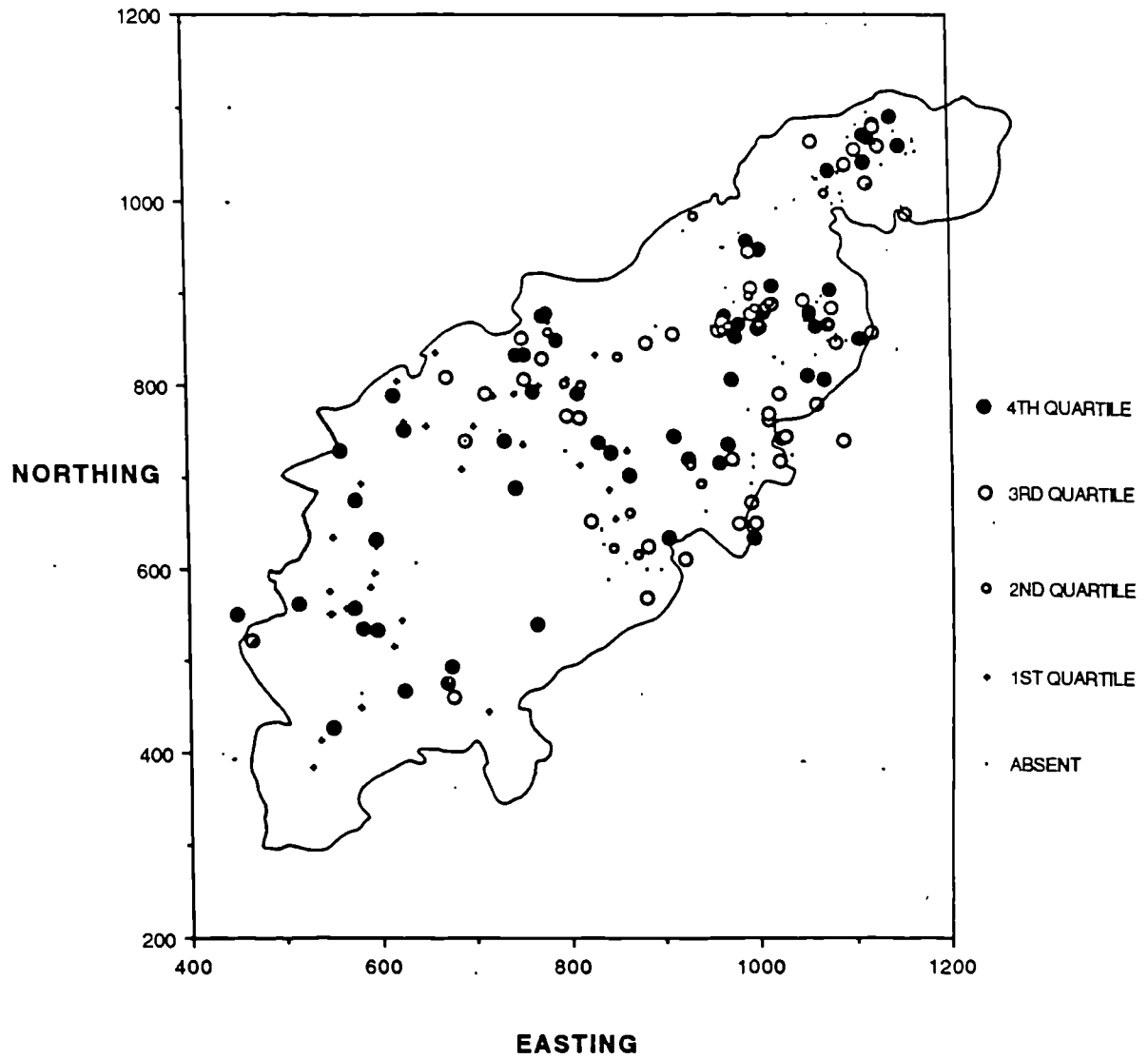

Figure 7.20 Distribution map of all Early/Mid scatters by residual quartile

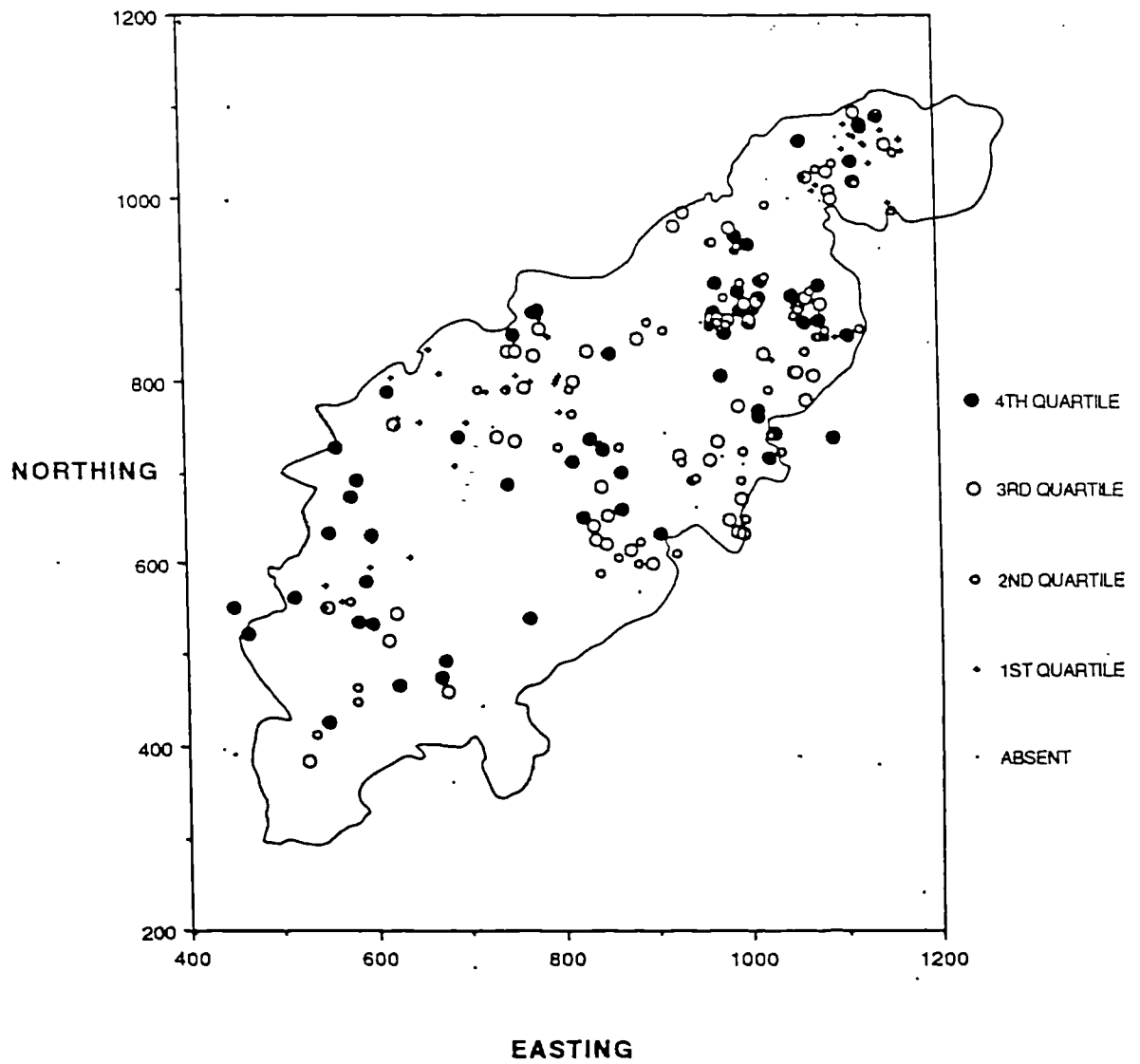

Figure 7.21 Distribution map of all Middle scatters by residual quartile

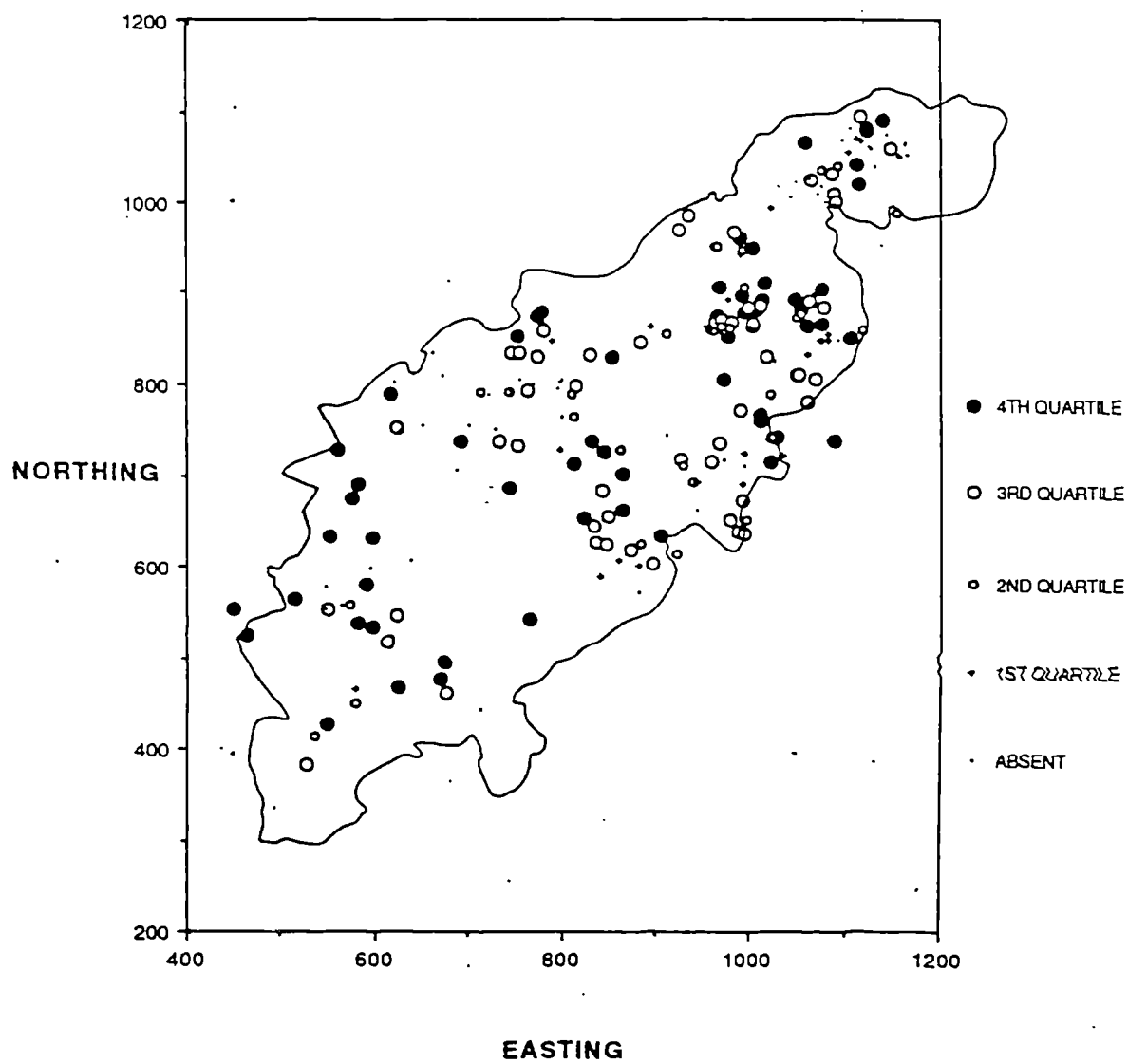

Figure 7.22 Distribution map of all Mid/Late scatters by residual quartile

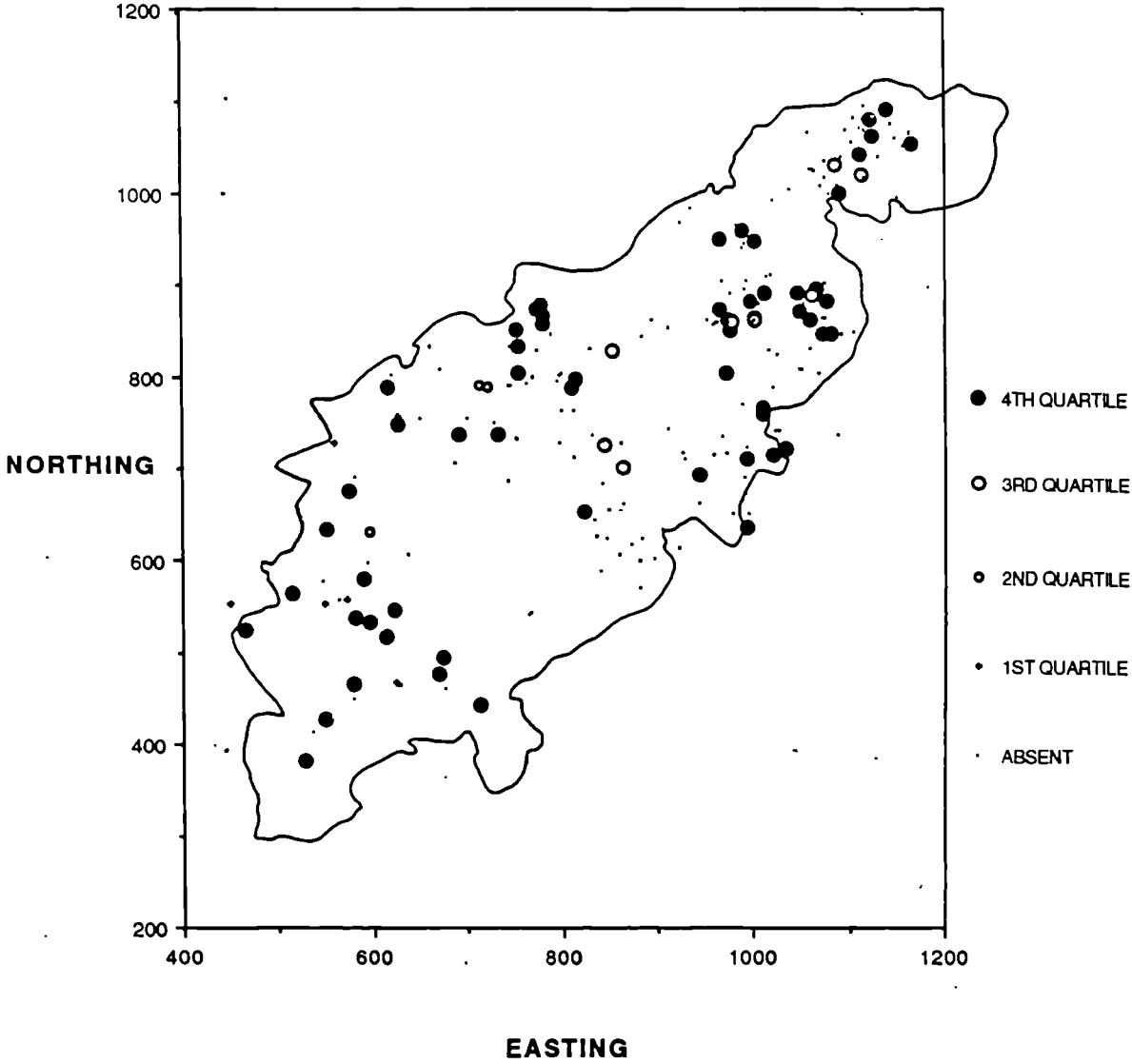

Figure 7.23 Distribution map of all Late scatters by residual quartile

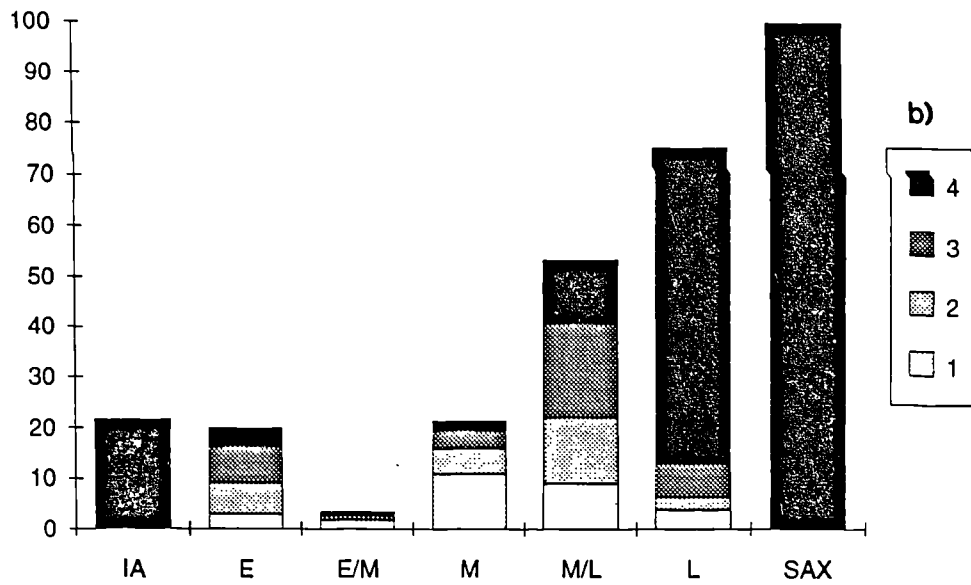
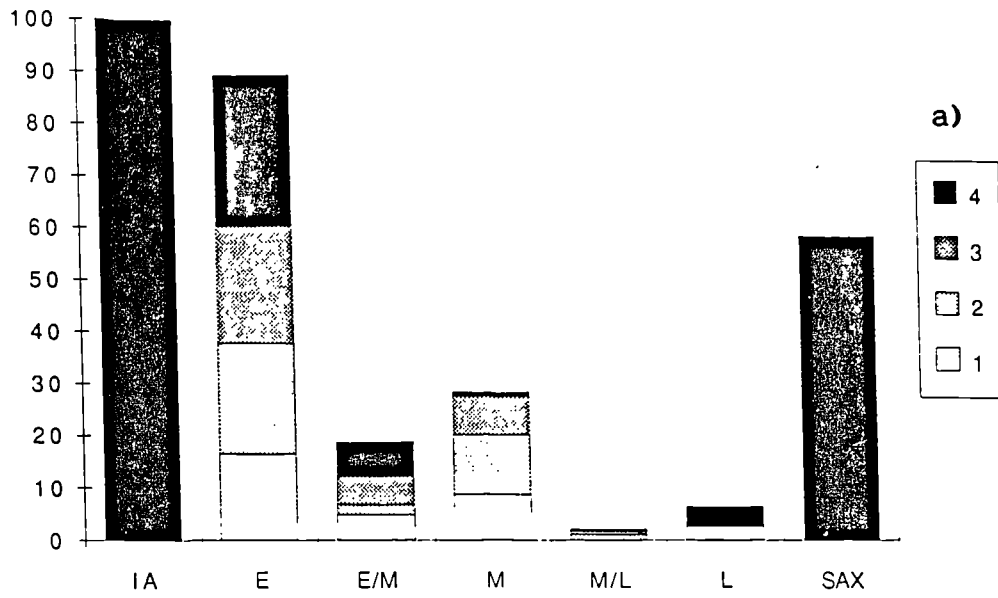

Figure 7.24 The proportion of scatters newly appearing in a period a), and not appearing in the subsequent period b) for the survey as a whole (1 = Lowest Quartile, 4 = Highest)

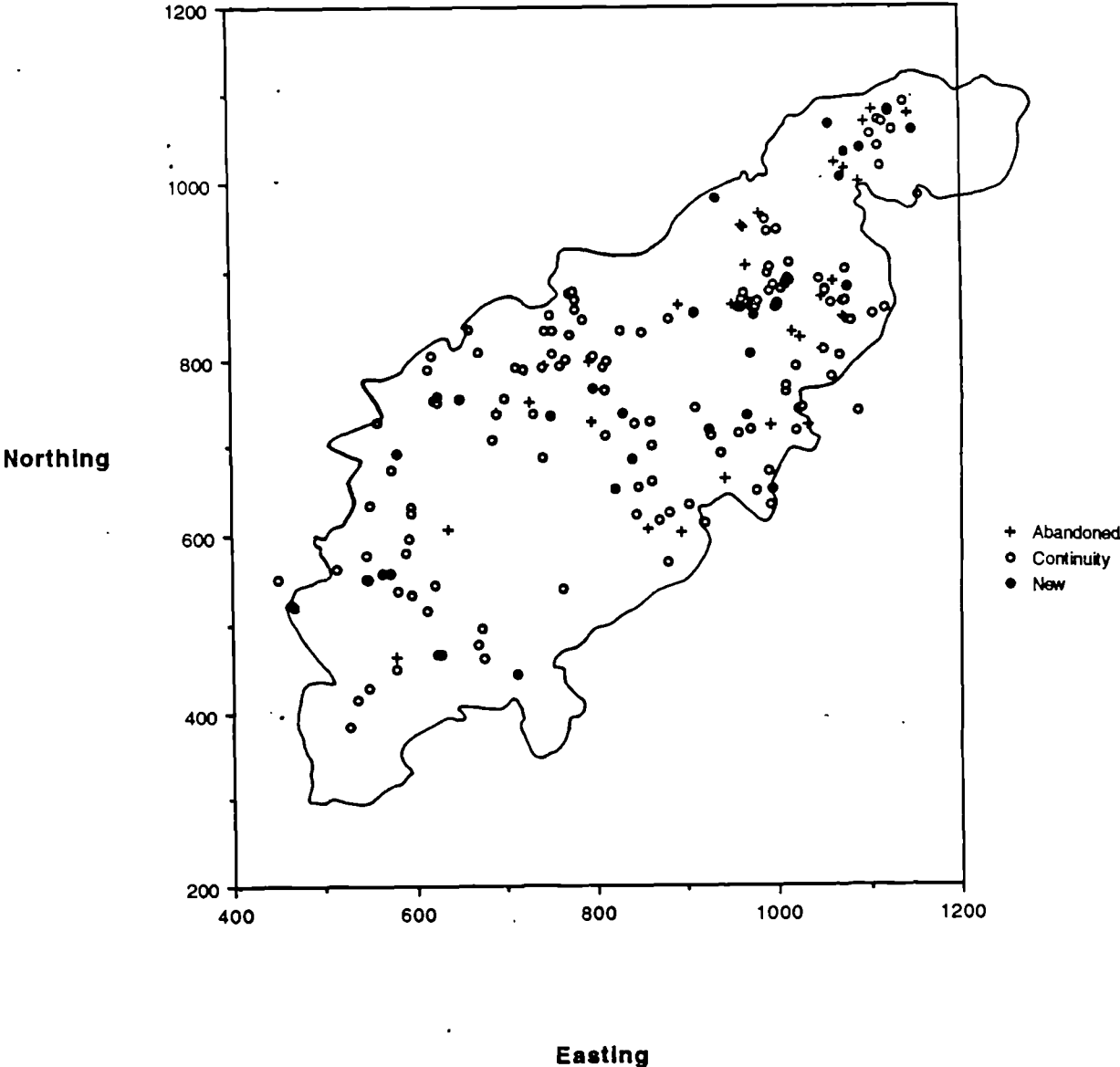

Figure 7.25 Distribution map of continuity and discontinuity in occupation between the Early and Early/Mid periods

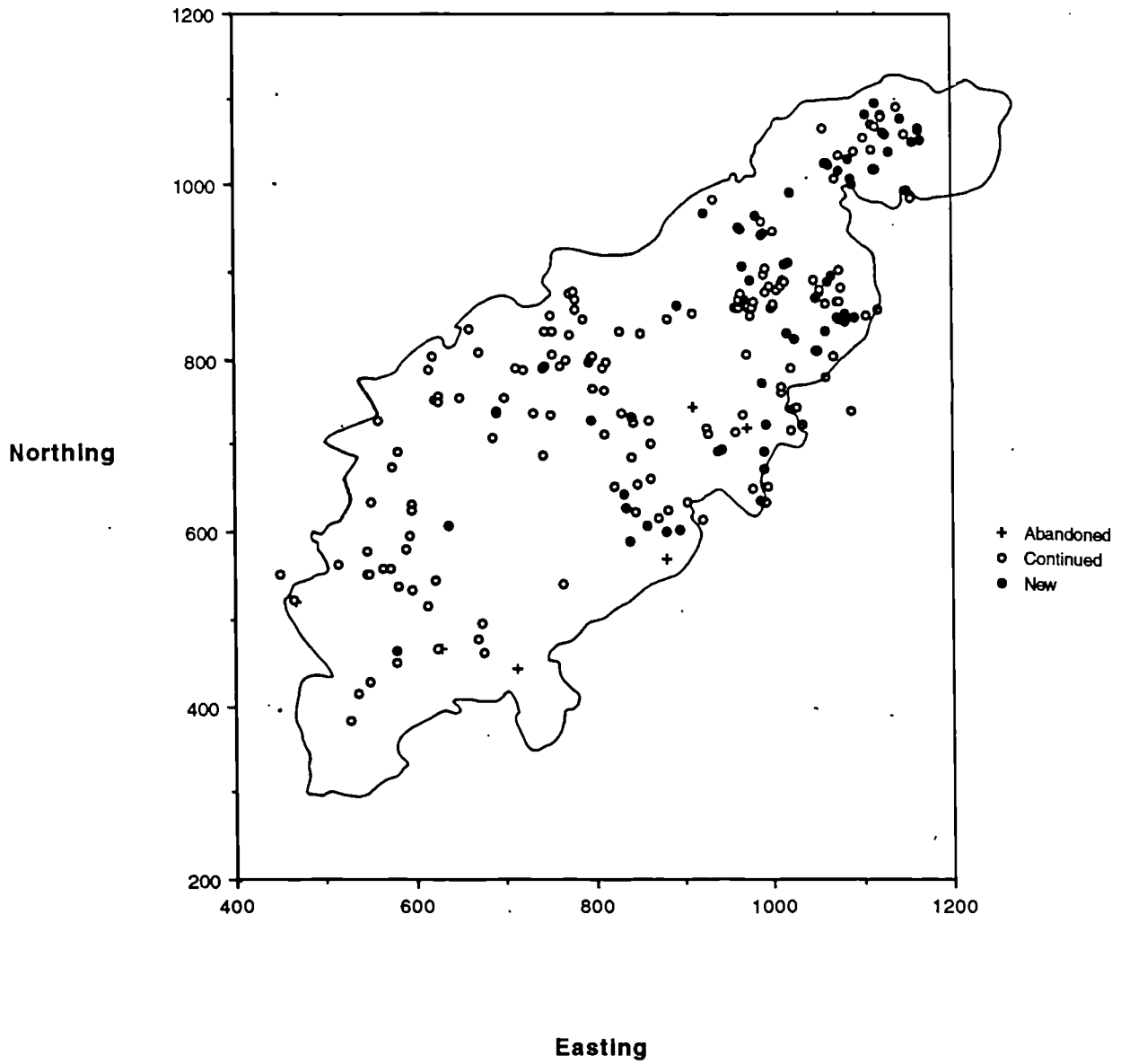

Figure 7.26 Distribution map of continuity and discontinuity in occupation between the Early/Mid and Middle periods

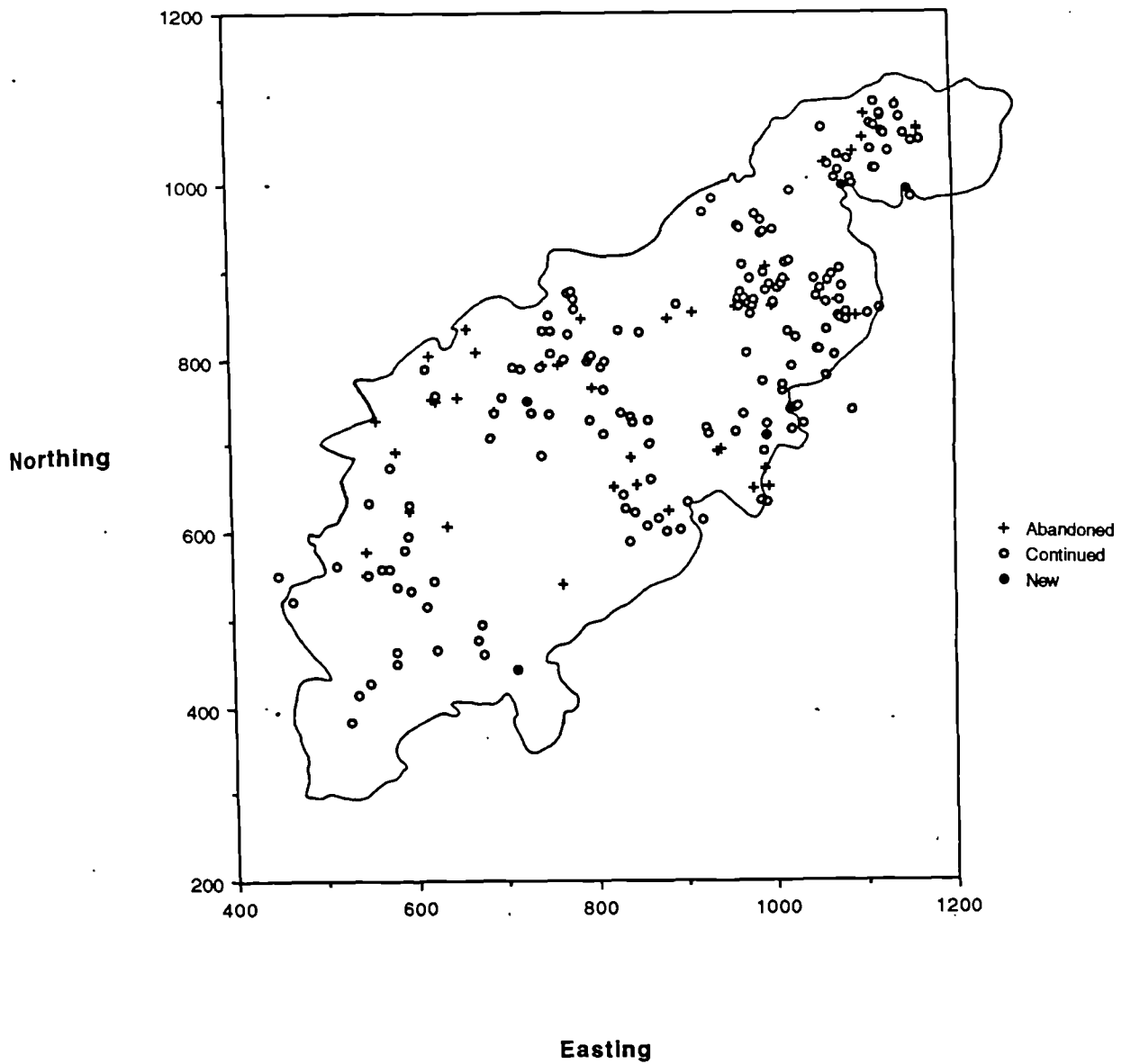

Figure 7.27 Distribution map of continuity and discontinuity in occupation between the Middle and Mid/Late periods

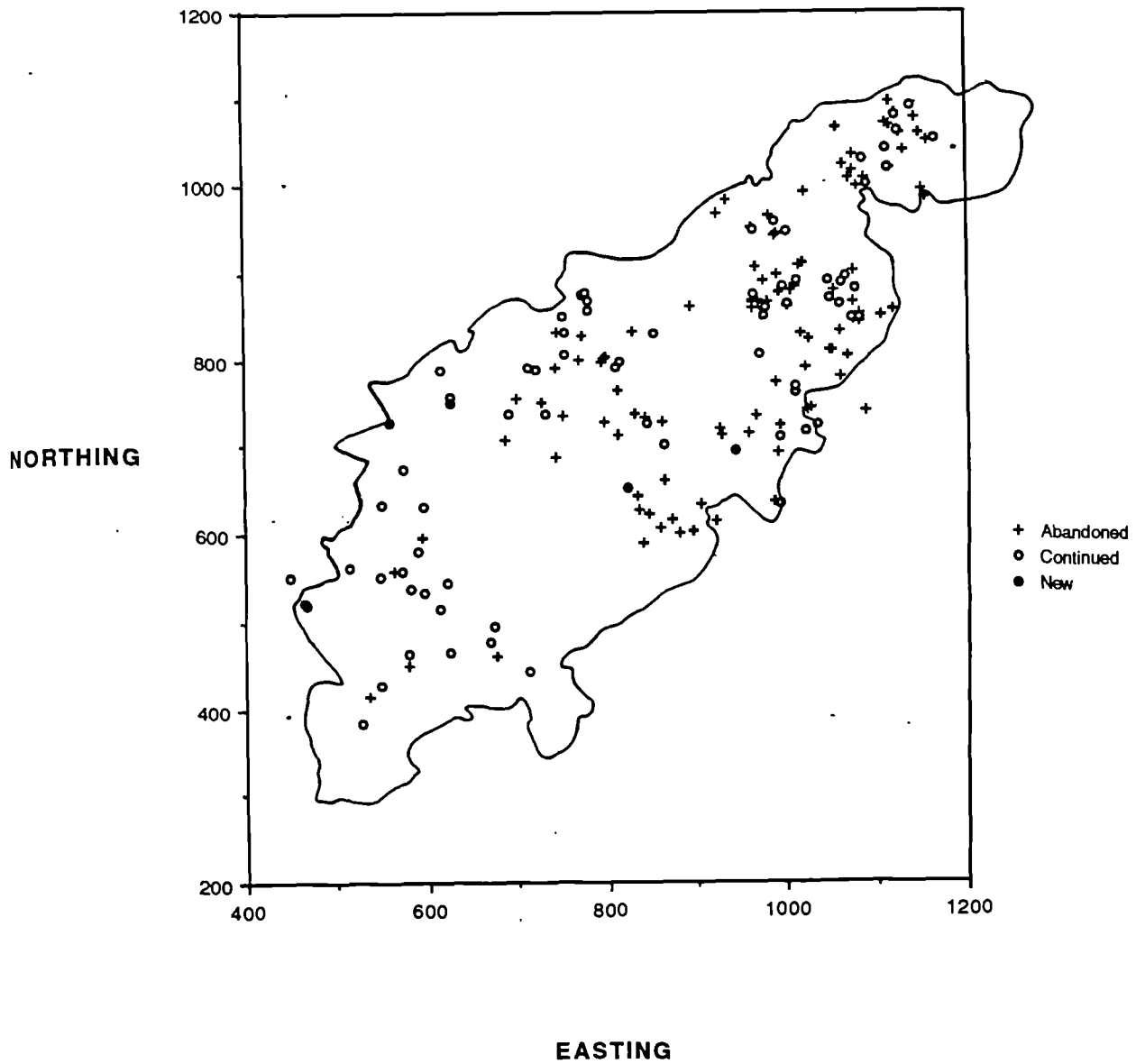

Figure 7.28 Distribution map of continuity and discontinuity in occupation between the Mid/Late and Late periods

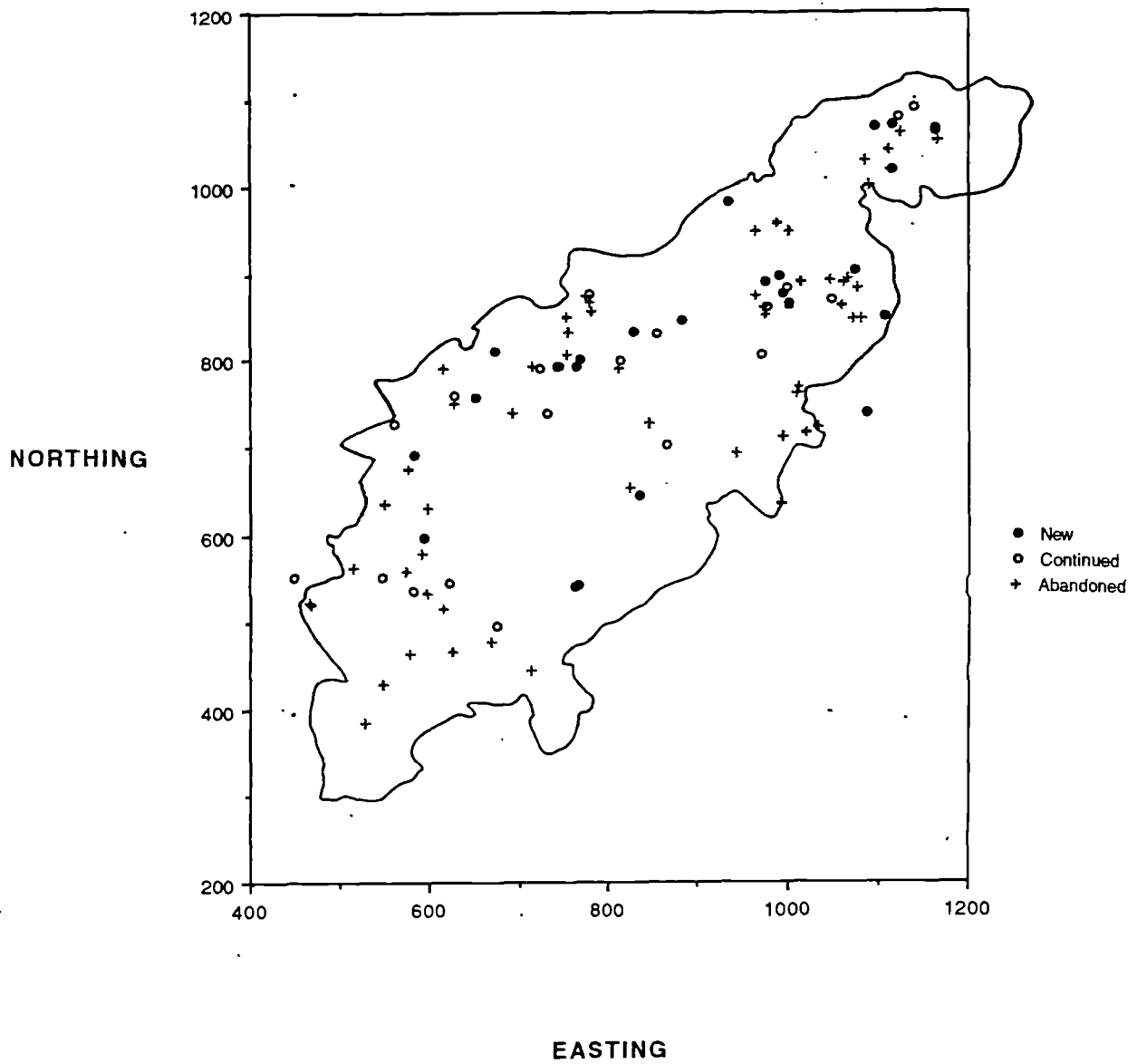

Figure 7.29 Distribution map of continuity and discontinuity in occupation between the Late and Saxon periods

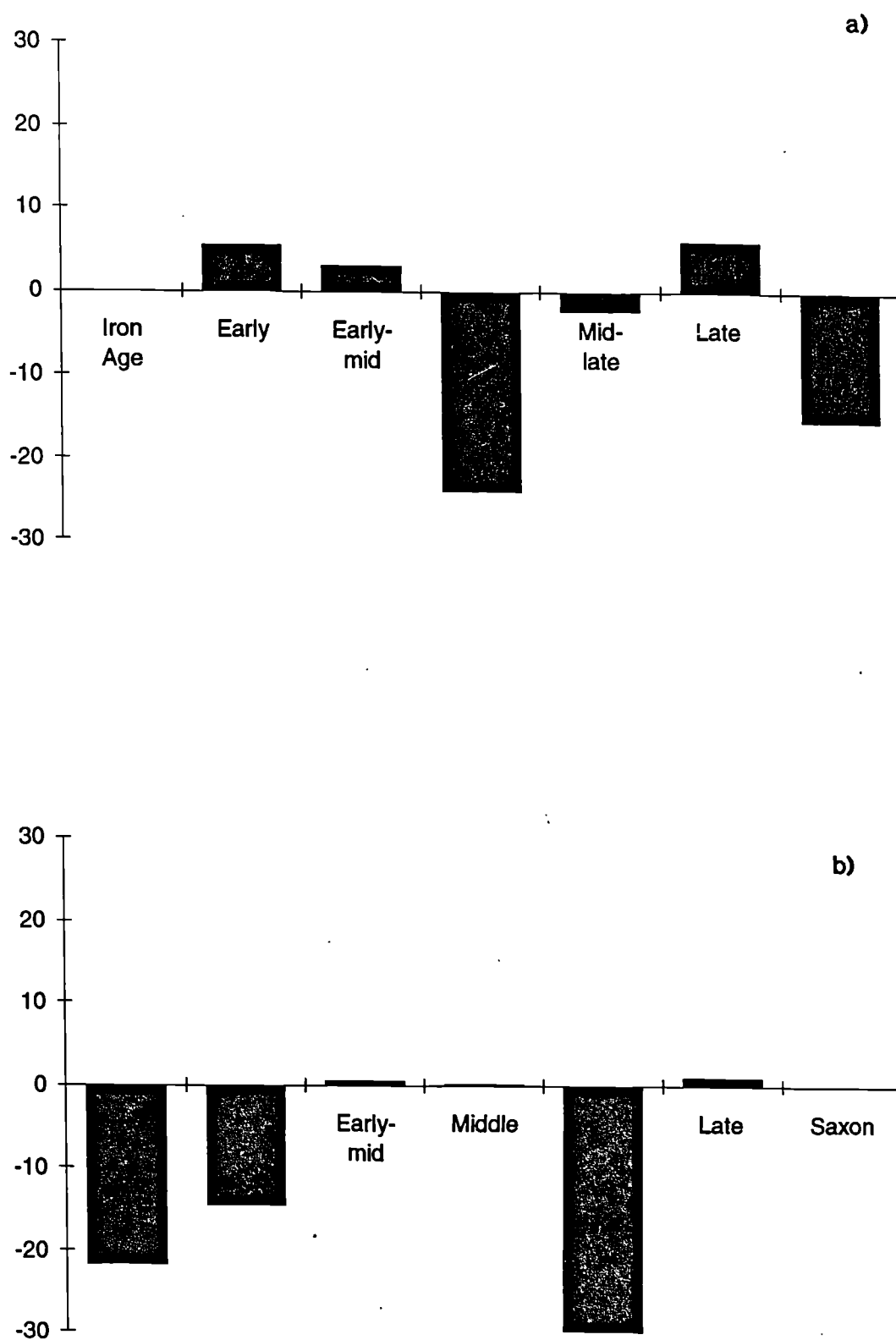

Figure 7.30 The percentage deviation from the survey mean of new occupation a), and abandonment b) in area 1

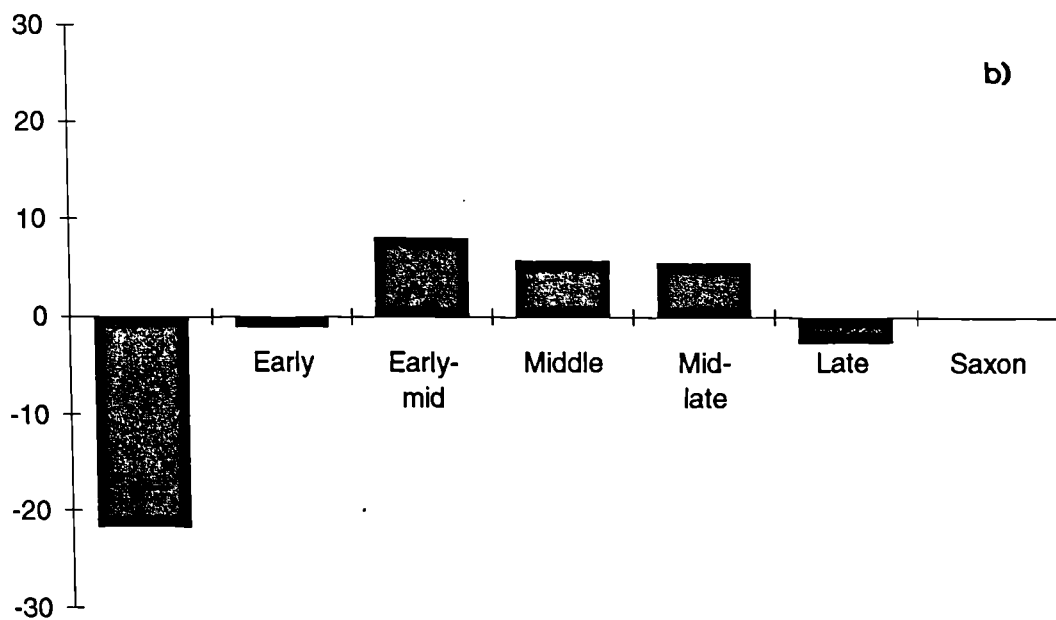
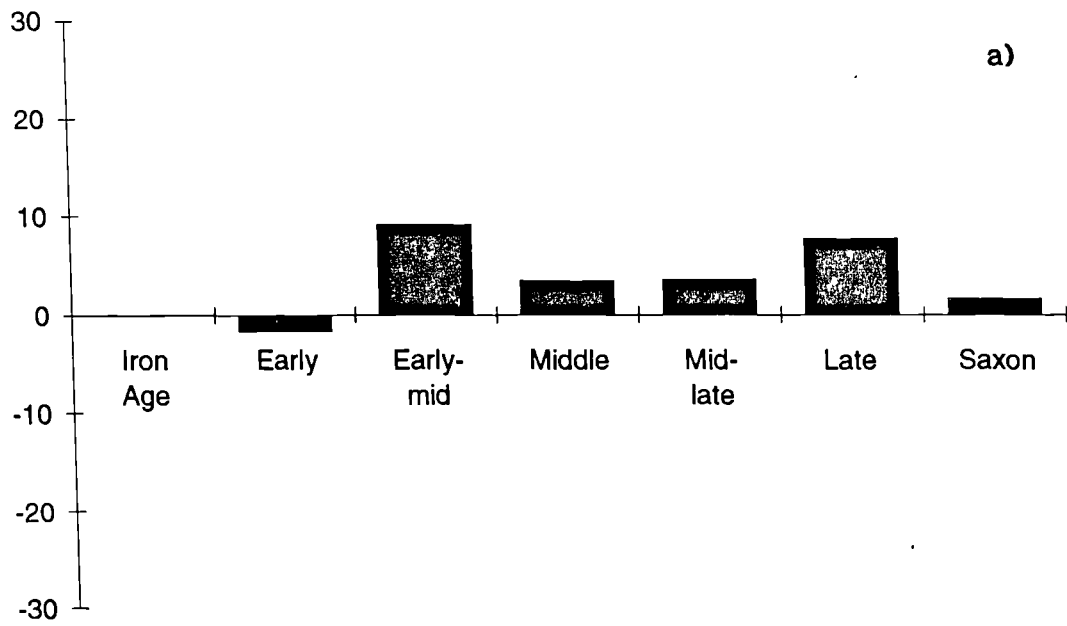

Figure 7.31 The percentage deviation from the survey mean of new occupation a), and abandonment b) in area 2

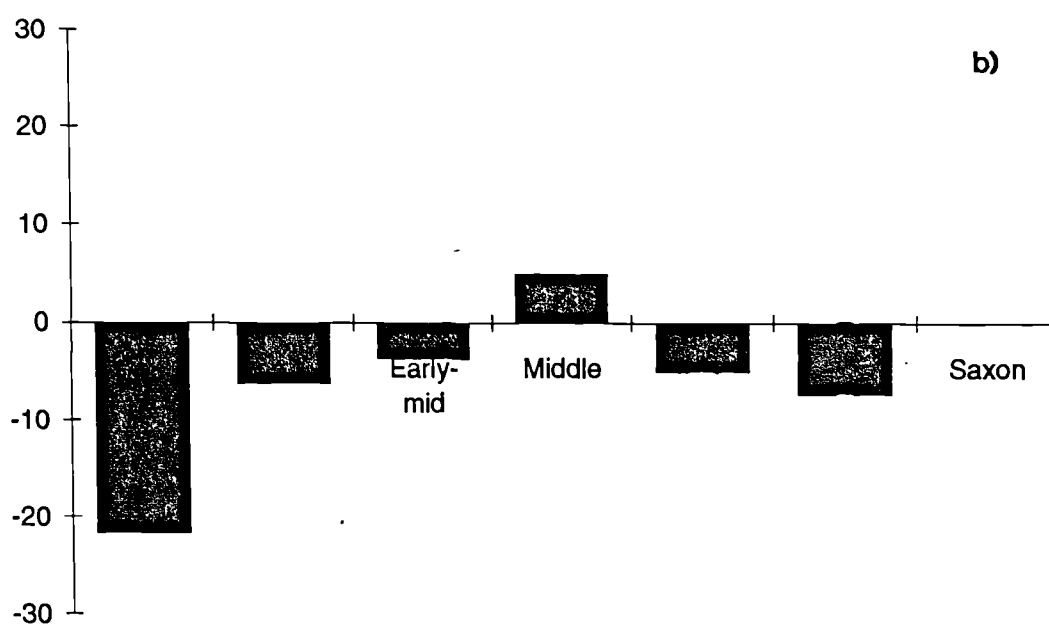
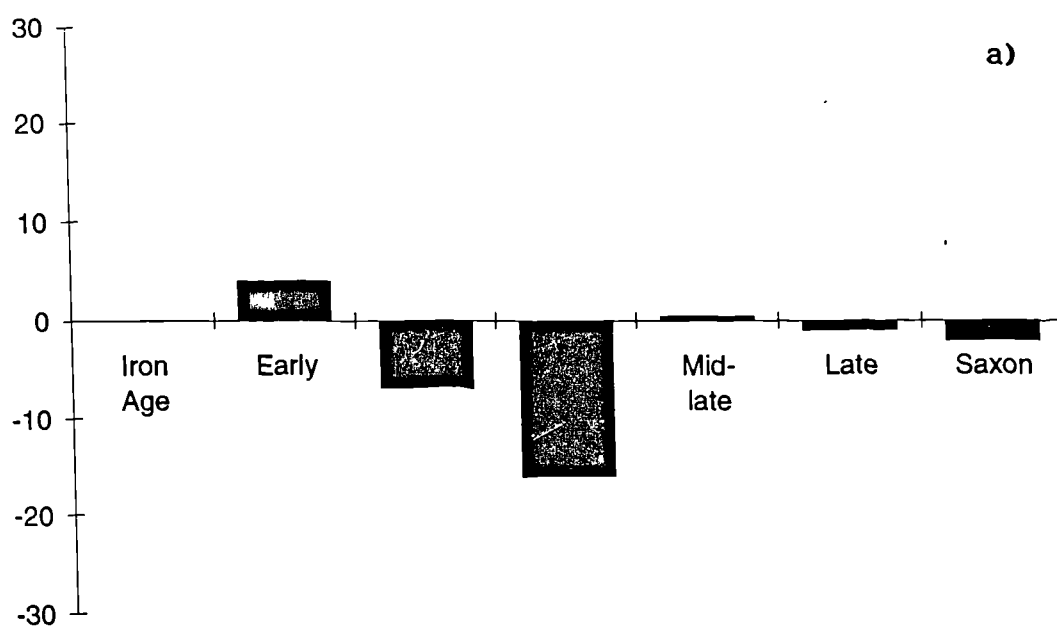

Figure 7.32 The percentage deviation from the survey mean of new occupation a), and abandonment b) in area 3

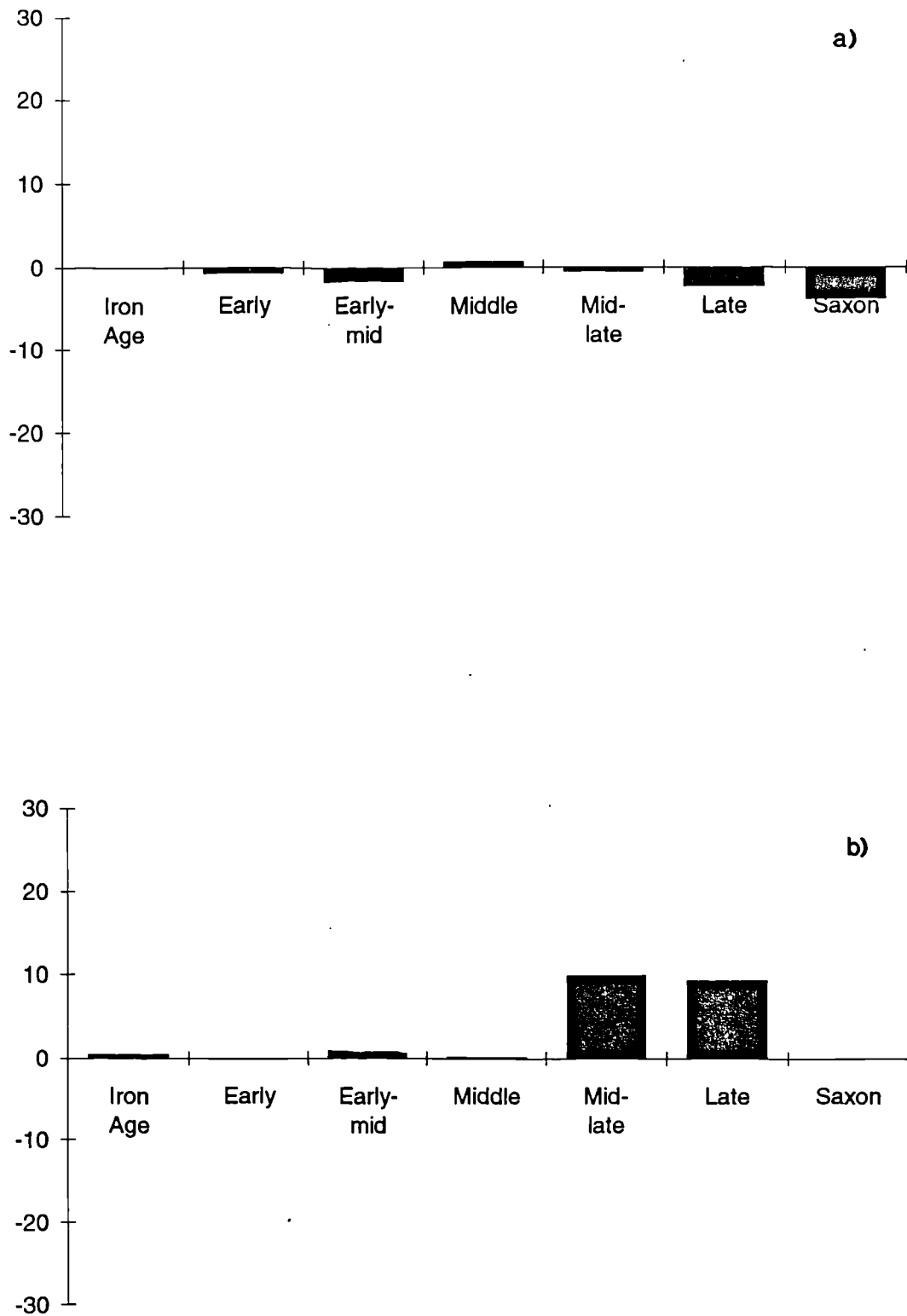

Figure 7.33 The percentage deviation from the survey mean of new occupation a), and abandonment b) in area 4

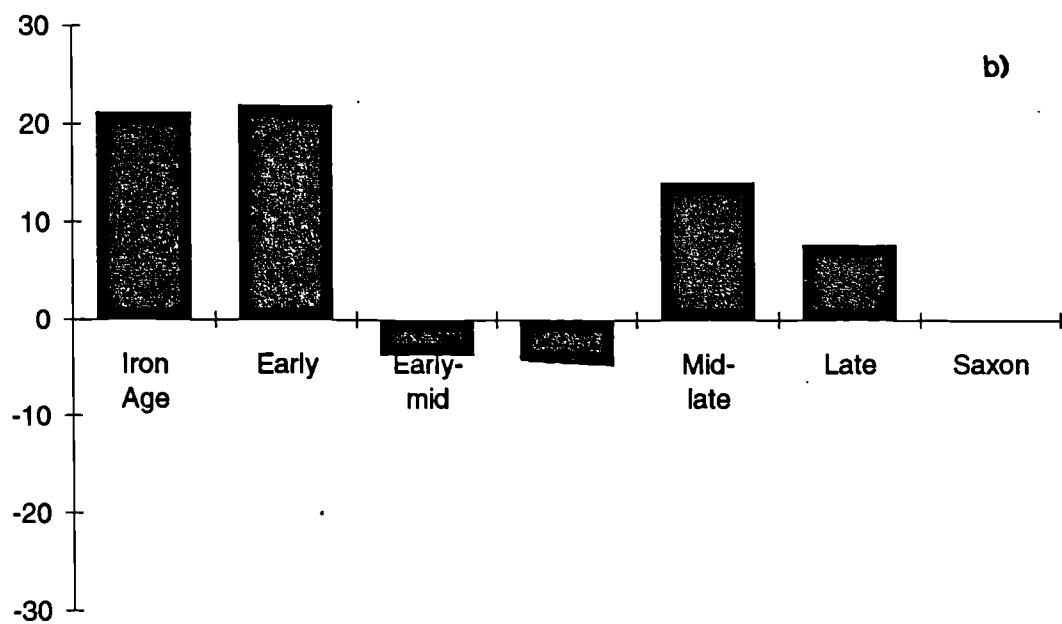
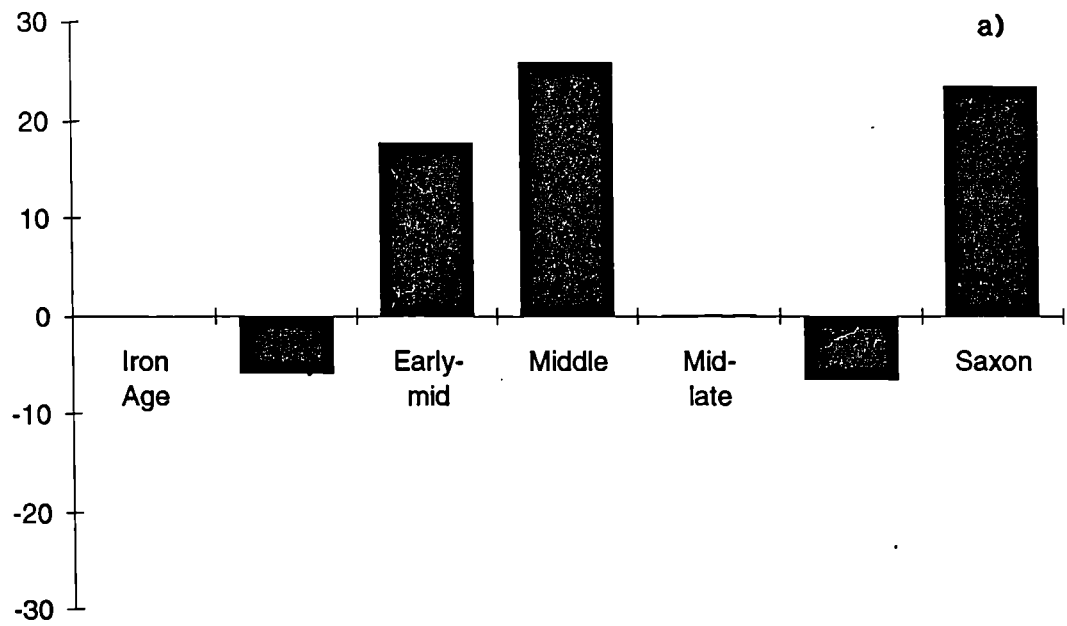

Figure 7.34 The percentage deviation from the survey mean of new occupation a), and abandonment b) in area 5

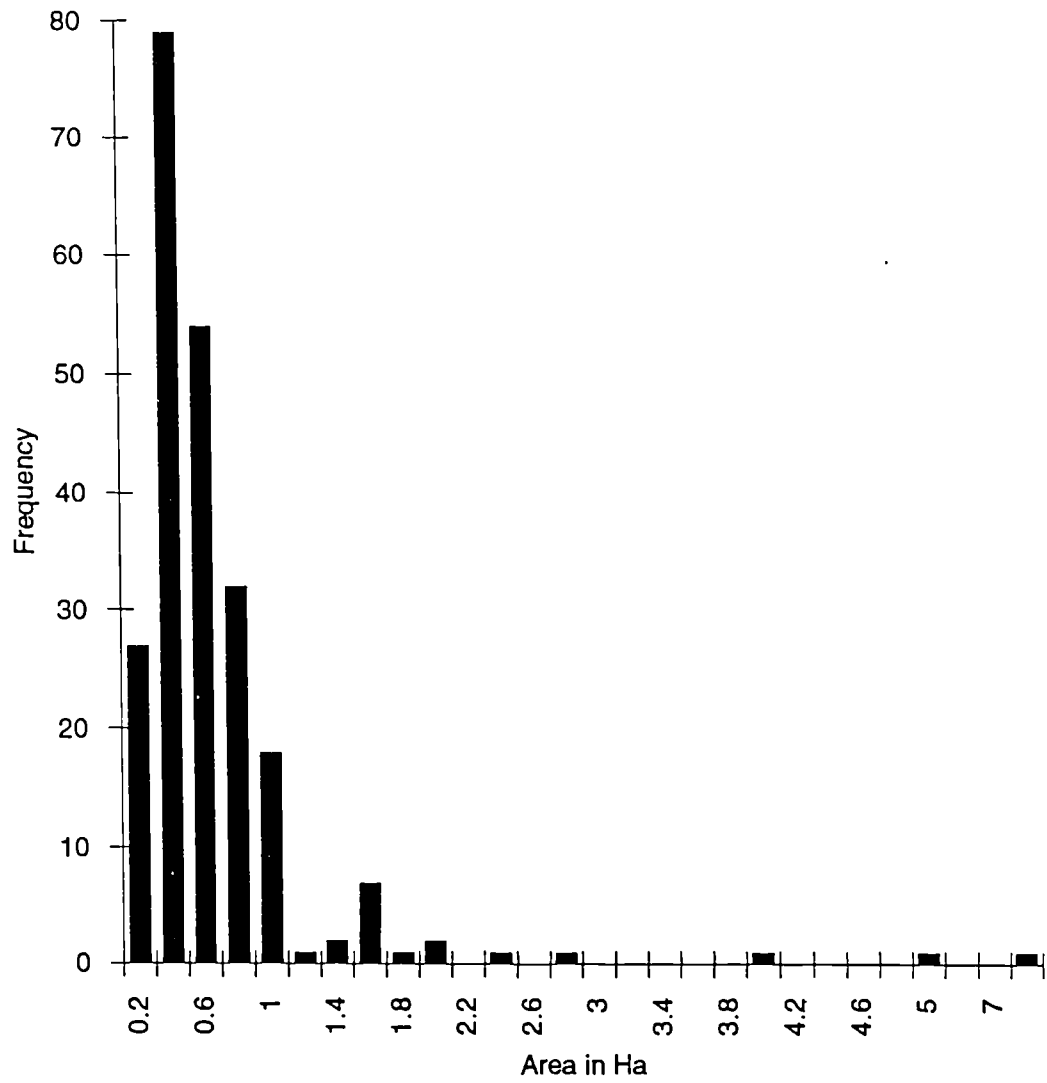

Figure 7.35 Frequency histogram of scatter areas for the survey

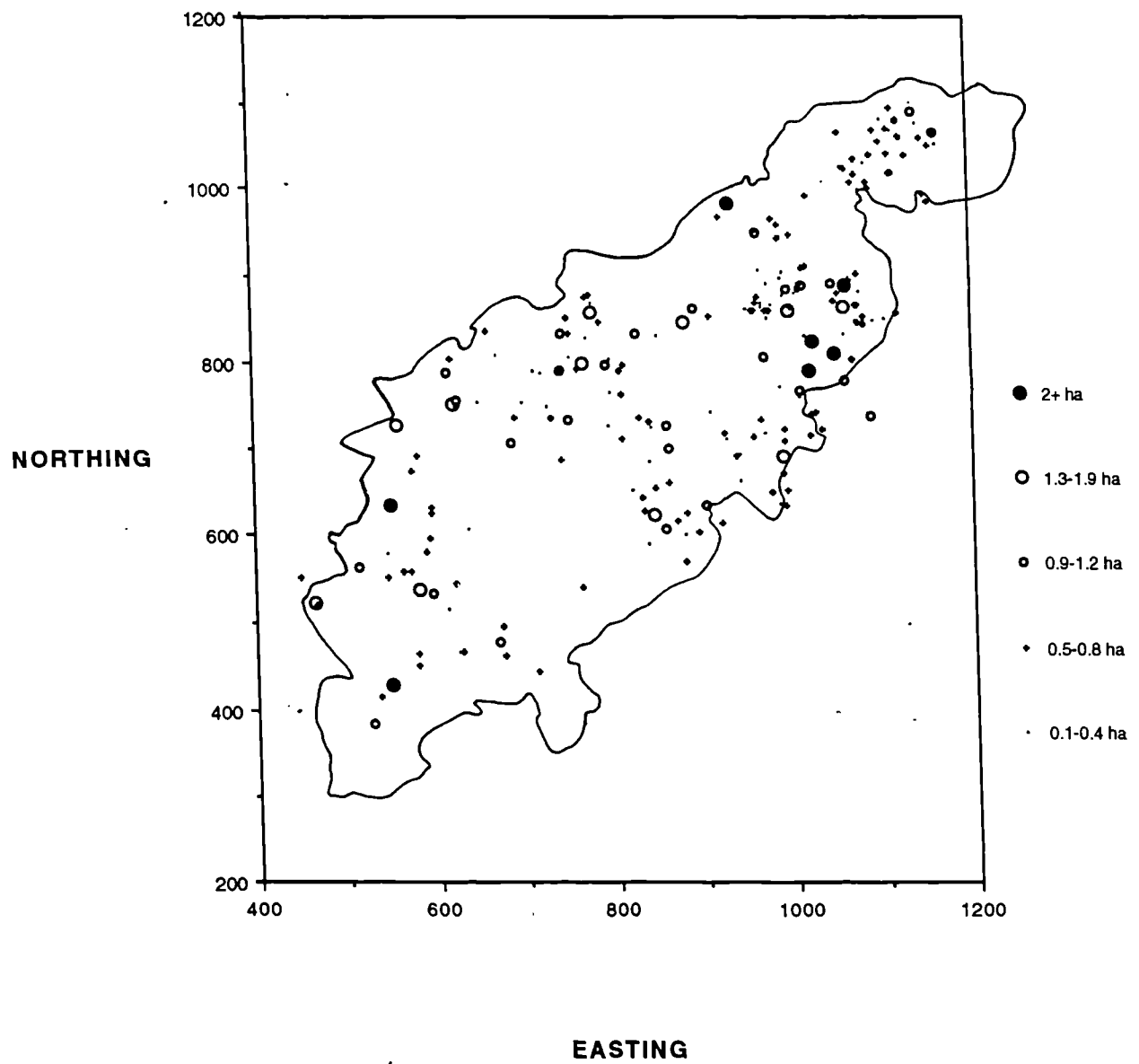

Figure 7.36 Distribution map of all the areas of scatters from the survey

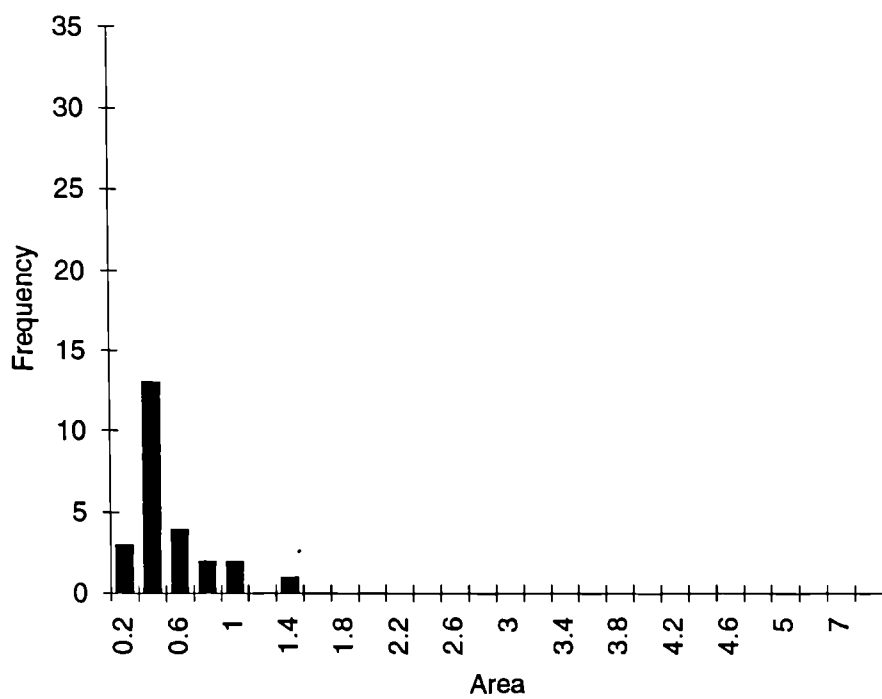
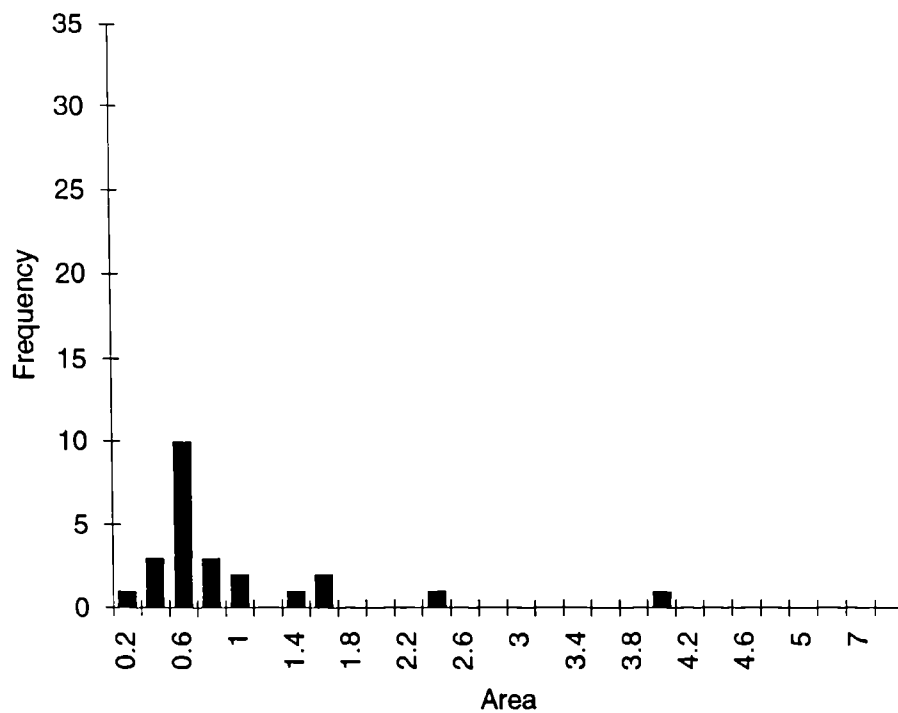

Figure 7.37 Frequency histogram of scatter areas for a) area 1 and b) area 2

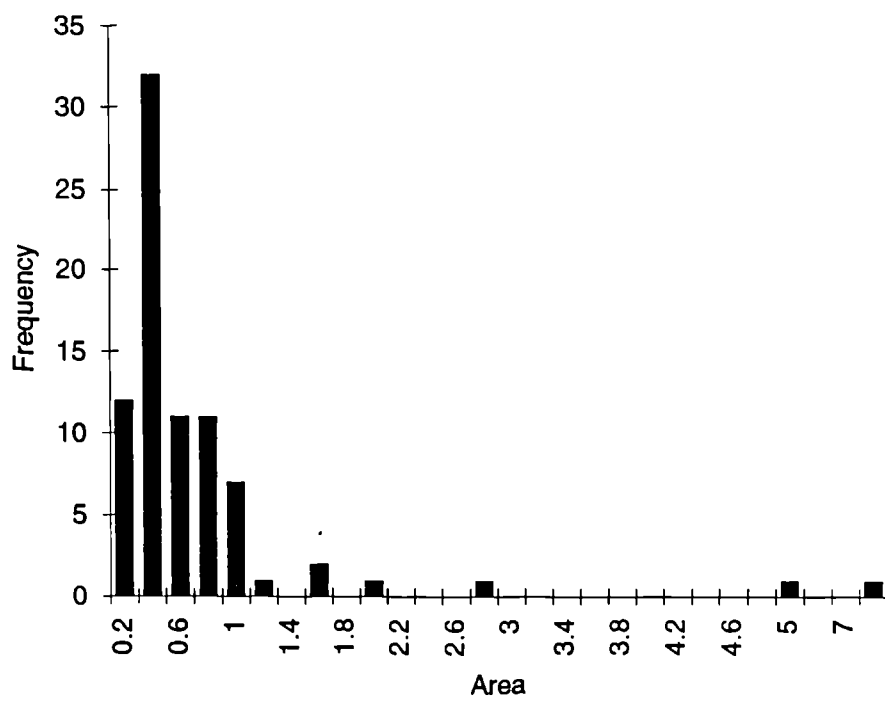
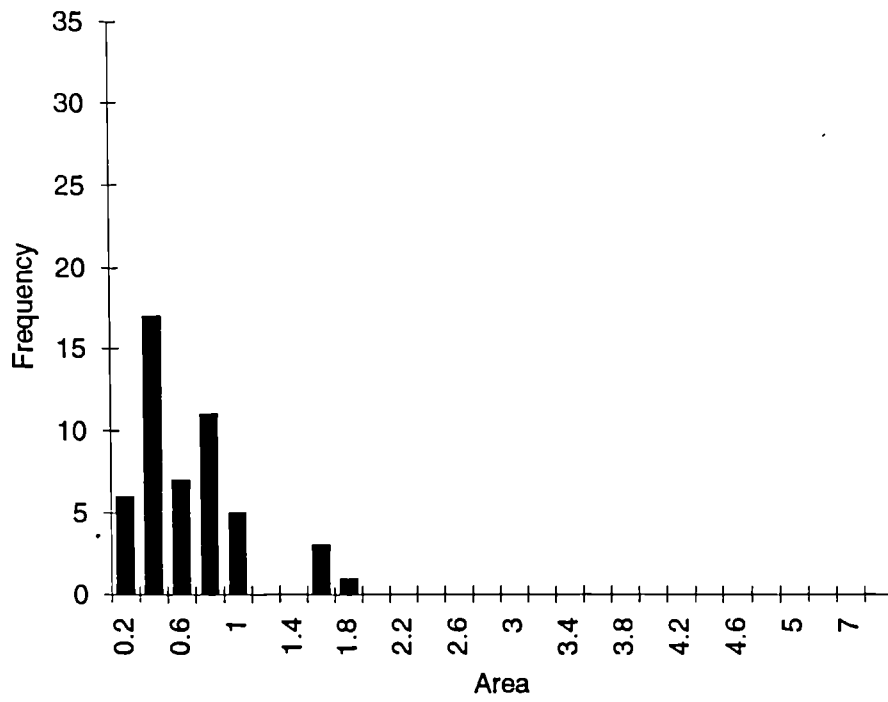

Figure 7.38 Frequency histogram of scatter areas for a) area 3 and b) area 4

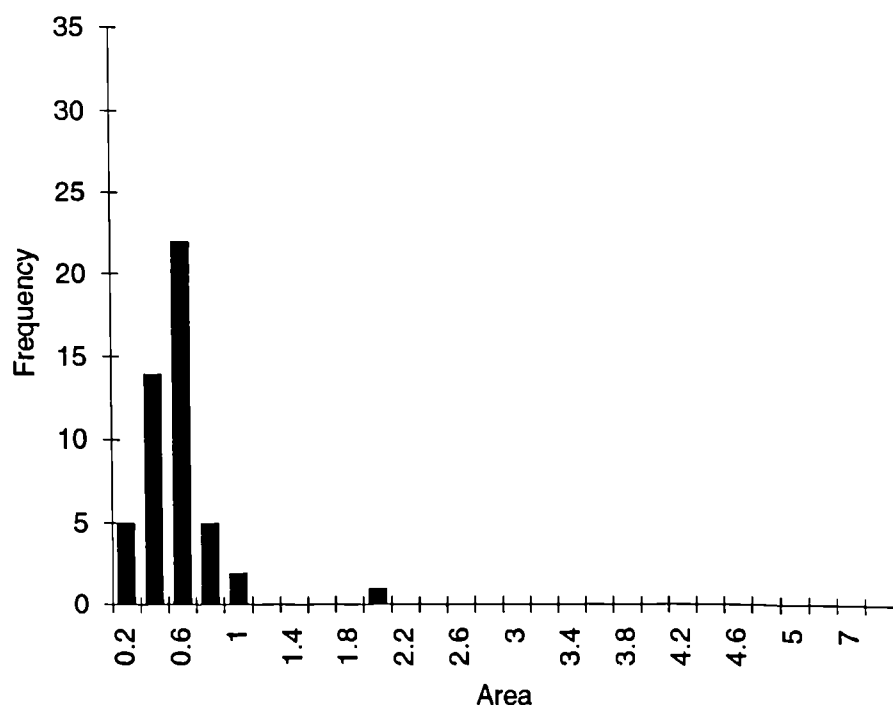

Figure 7.39 Frequency histogram of scatter areas for area 5

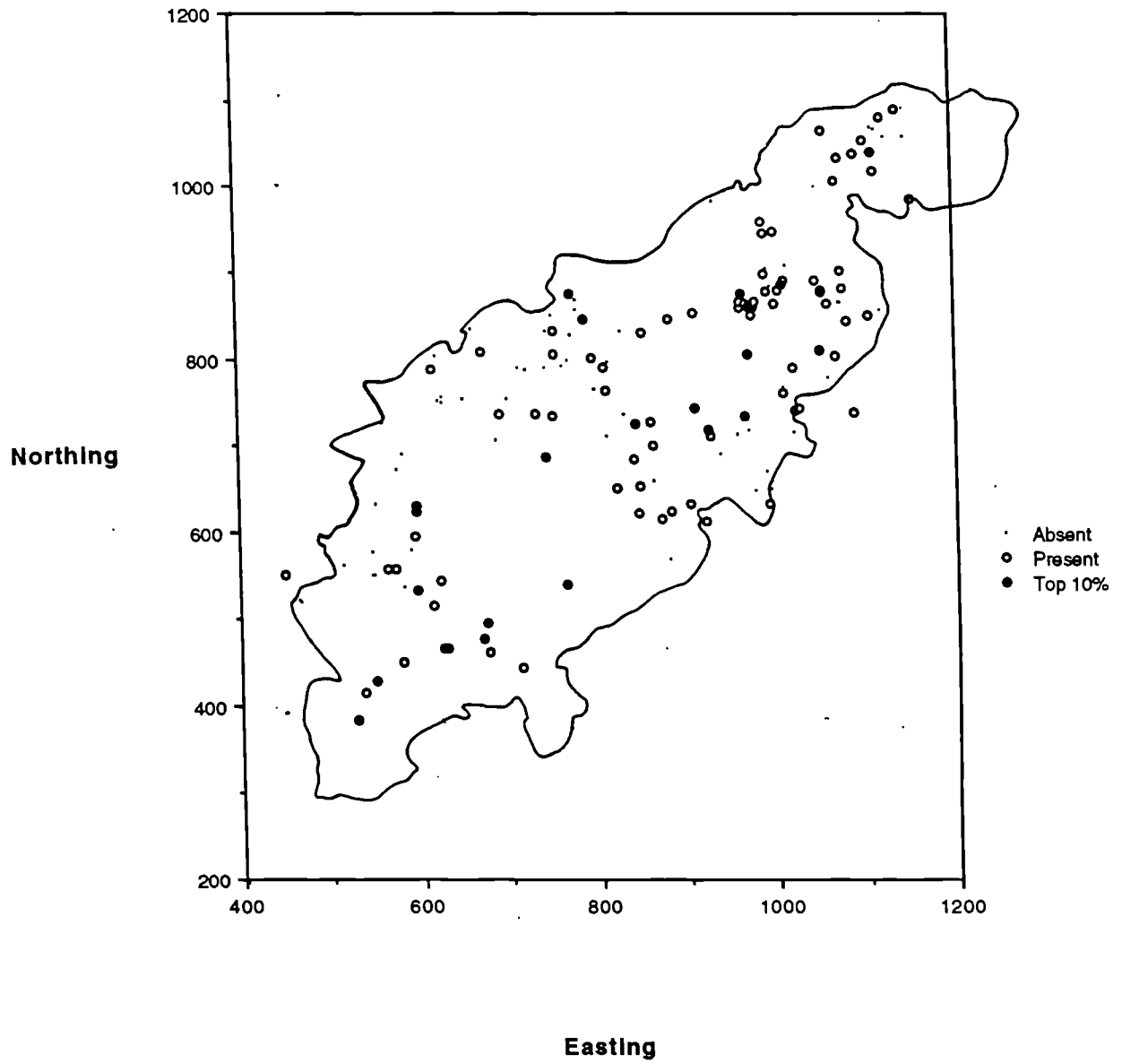

Figure 7.40 The distribution of Early/Mid period finewares

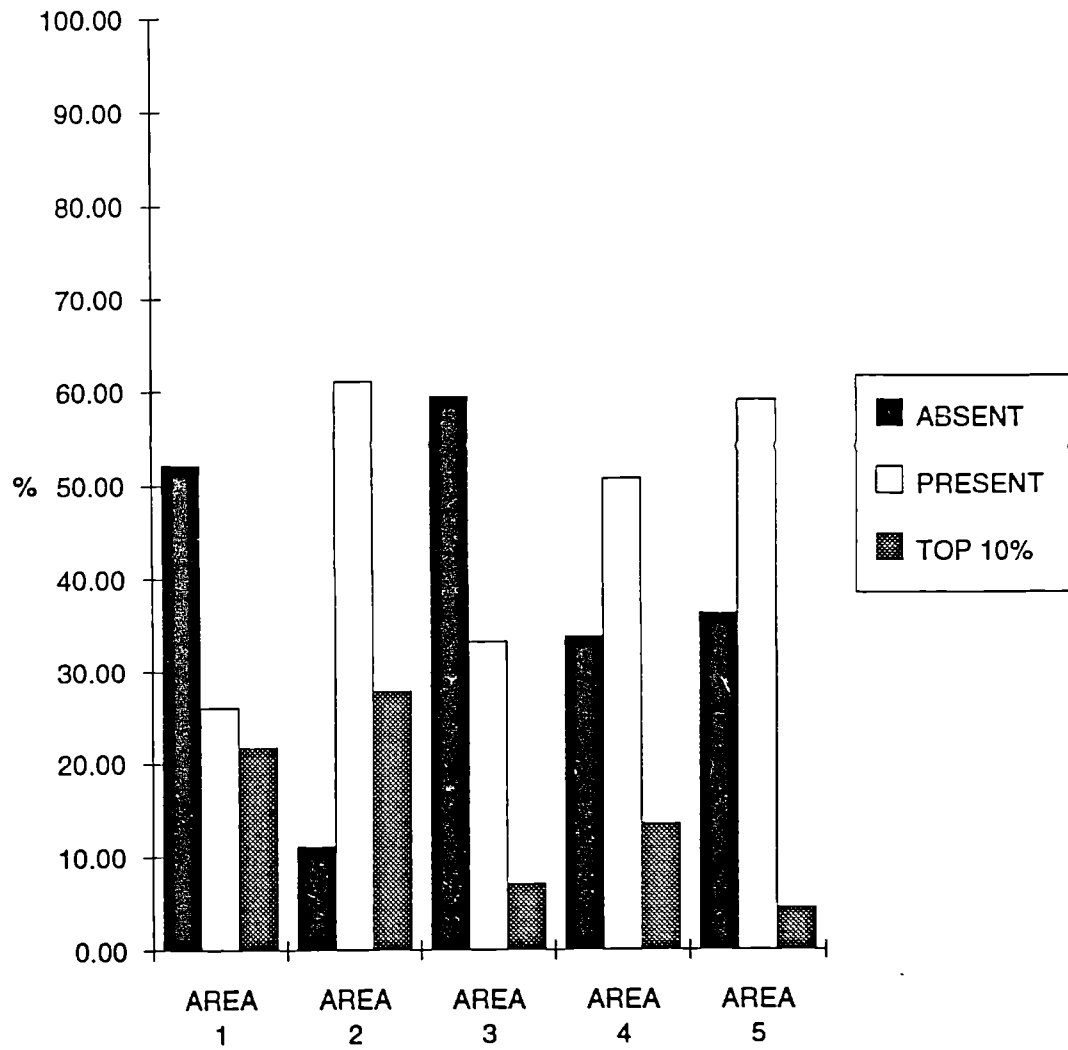

Figure 7.41 The proportions of Early/Mid finewares by sample area

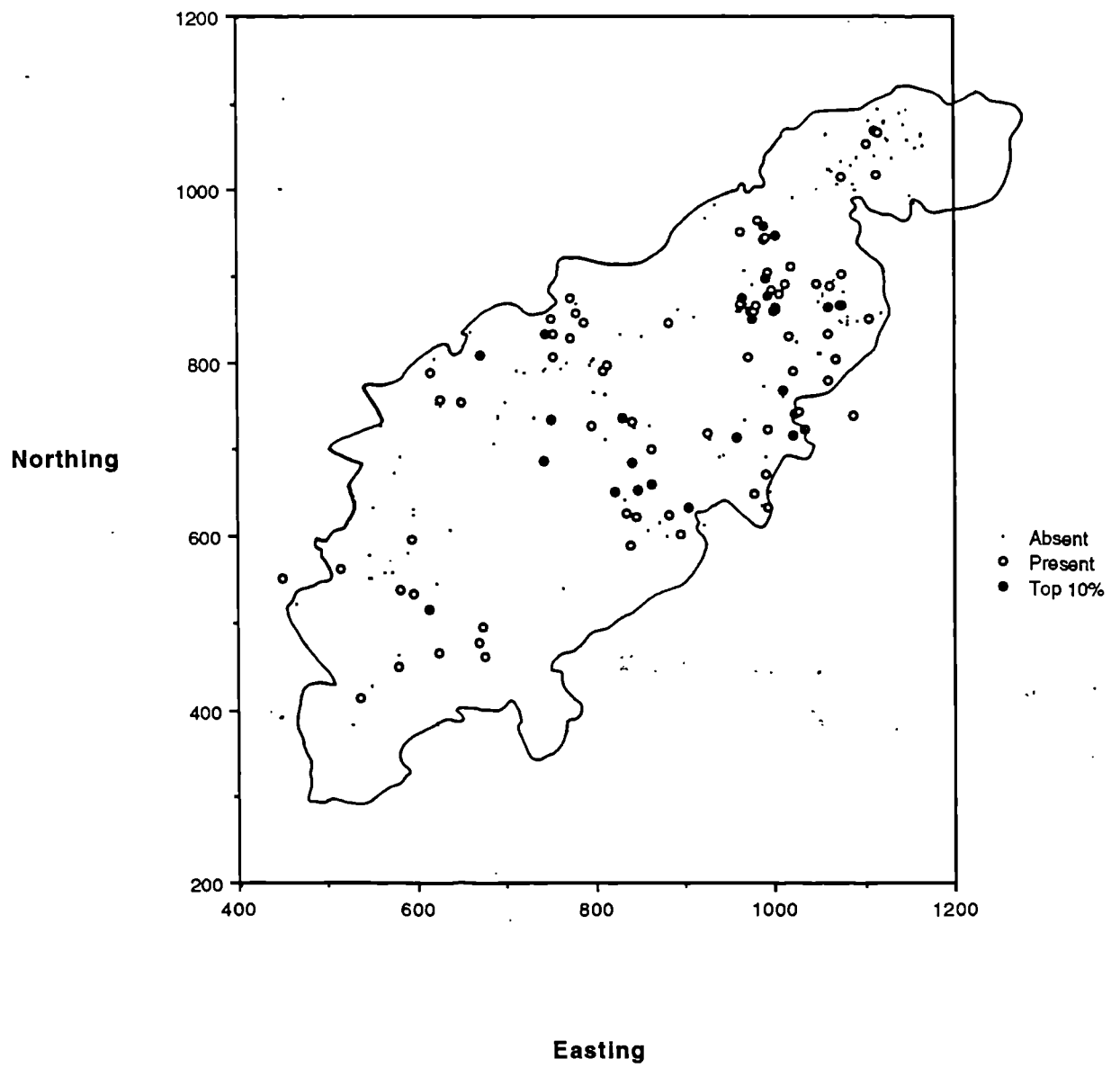

Figure 7.42 The distribution of Middle period finewares

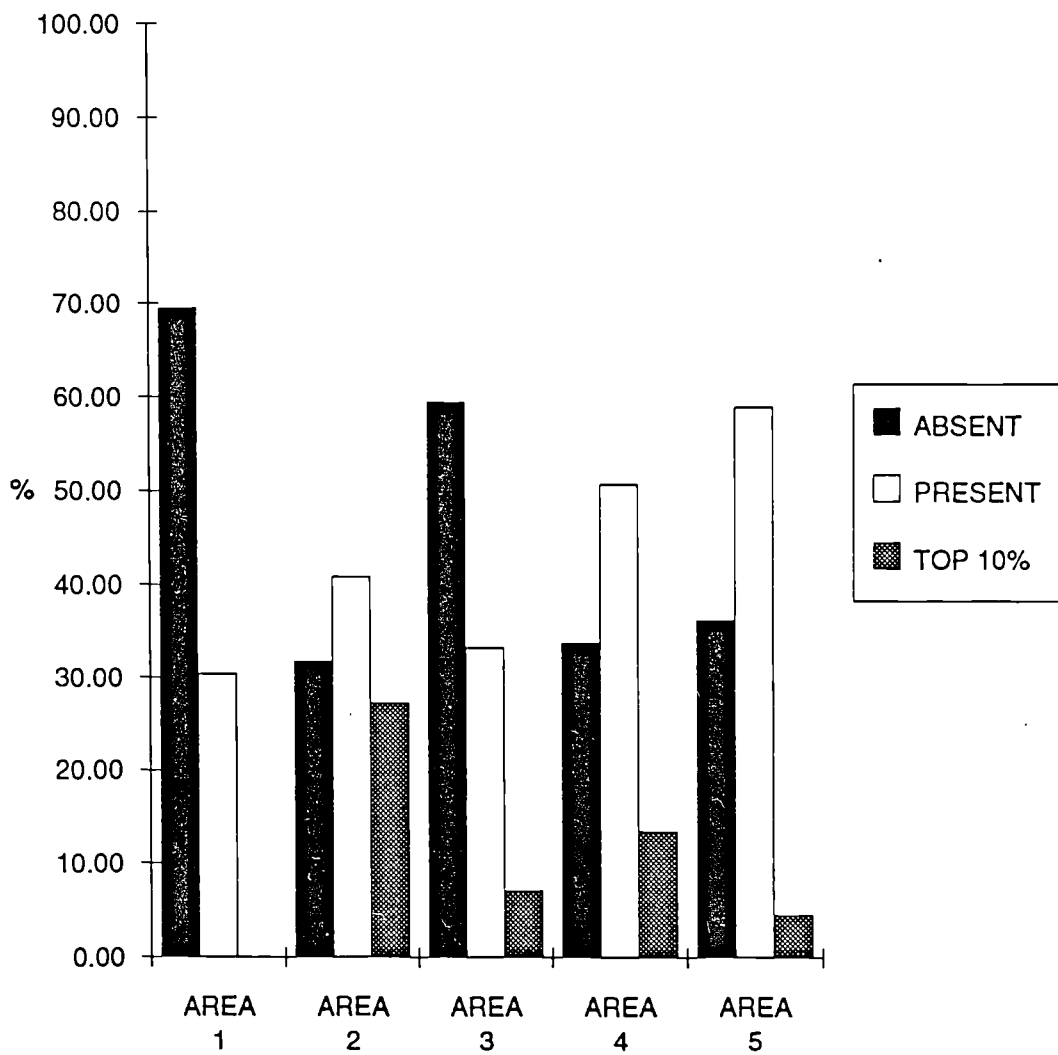

Figure 7.43 The proportions of Middle period finewares by sample area

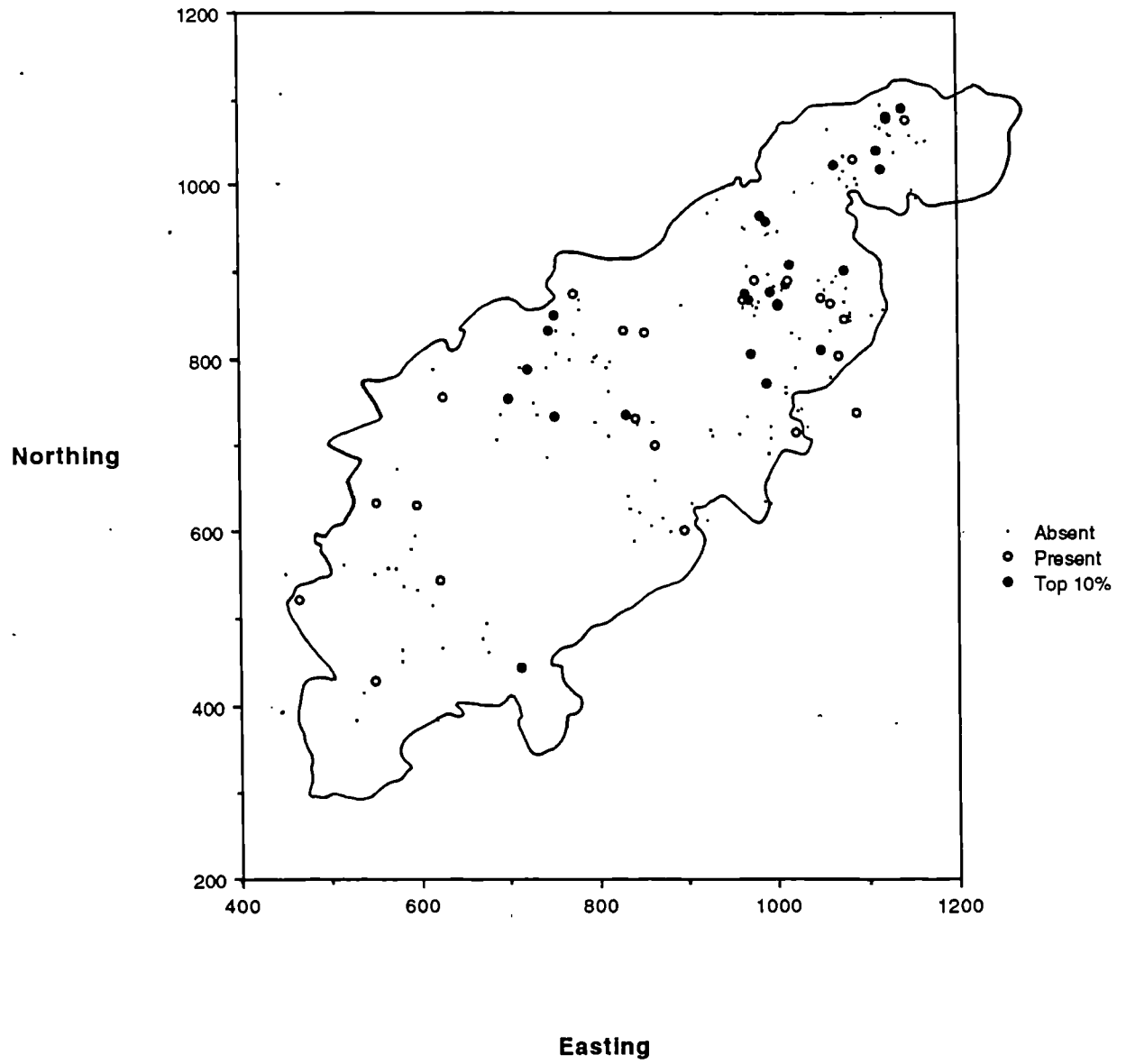

Figure 7.44 The distribution of Mid/Late period finewares

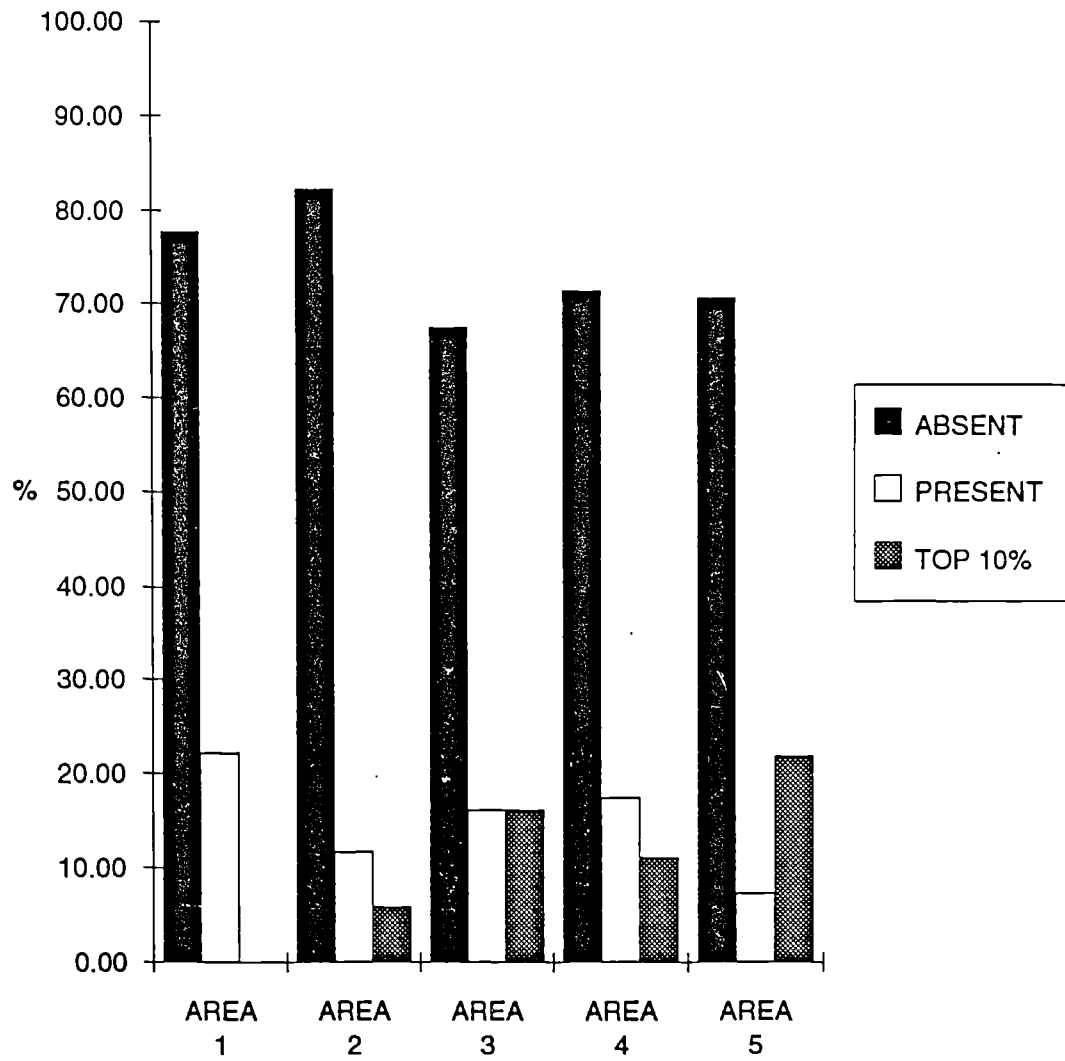

Figure 7.45 The proportions of Mid/Late period finewares by sample area

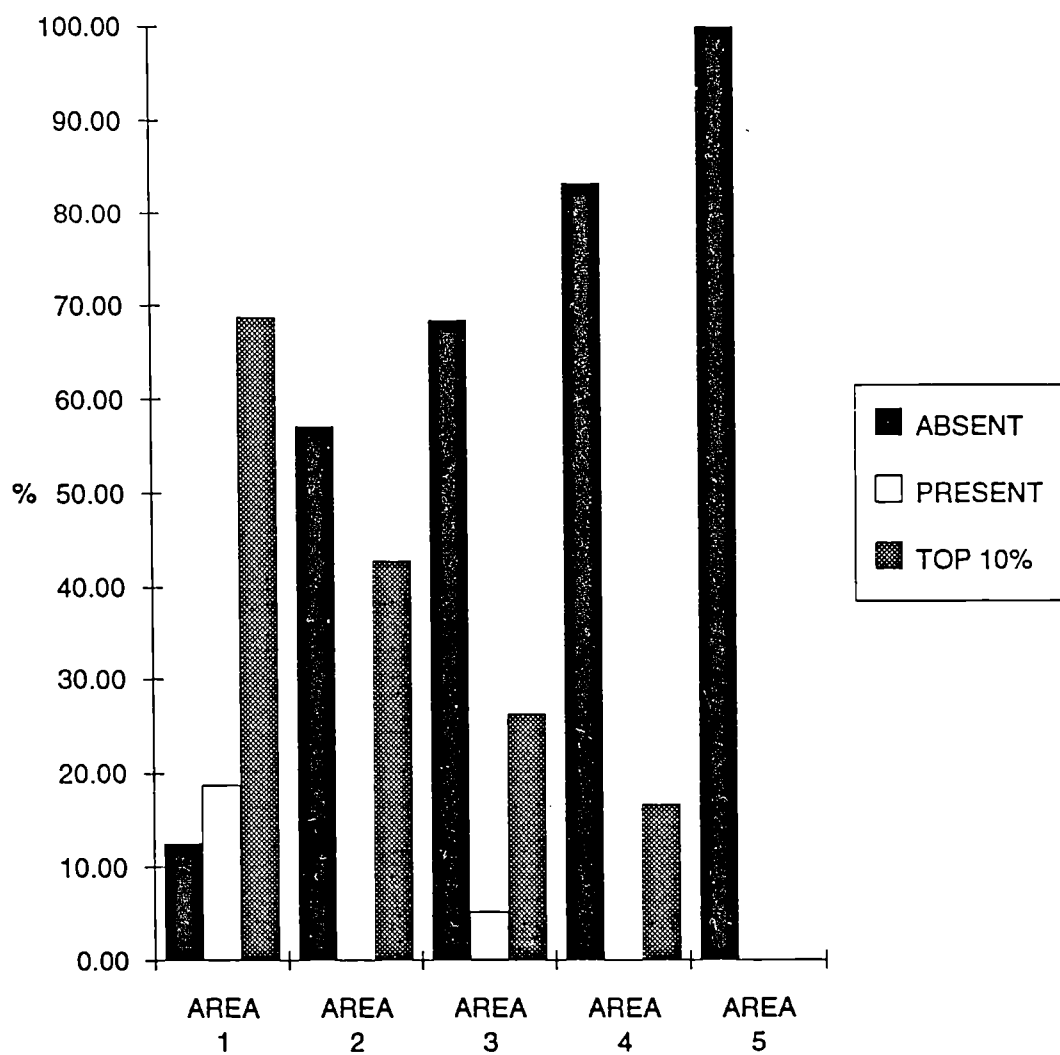

Figure 7.47 The proportions of Late period finewares by sample area

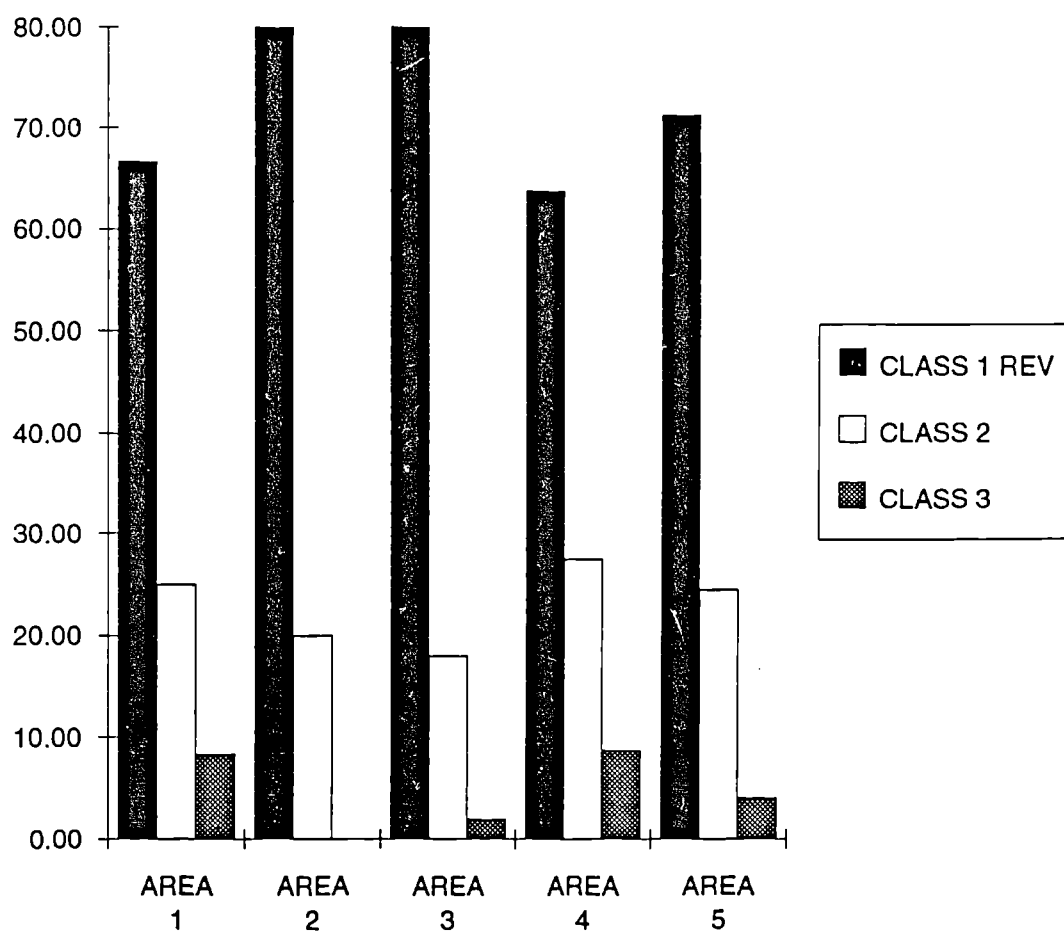

Figure 7.49 The proportions of structural class 1, 2 and 3 scatters by sample area

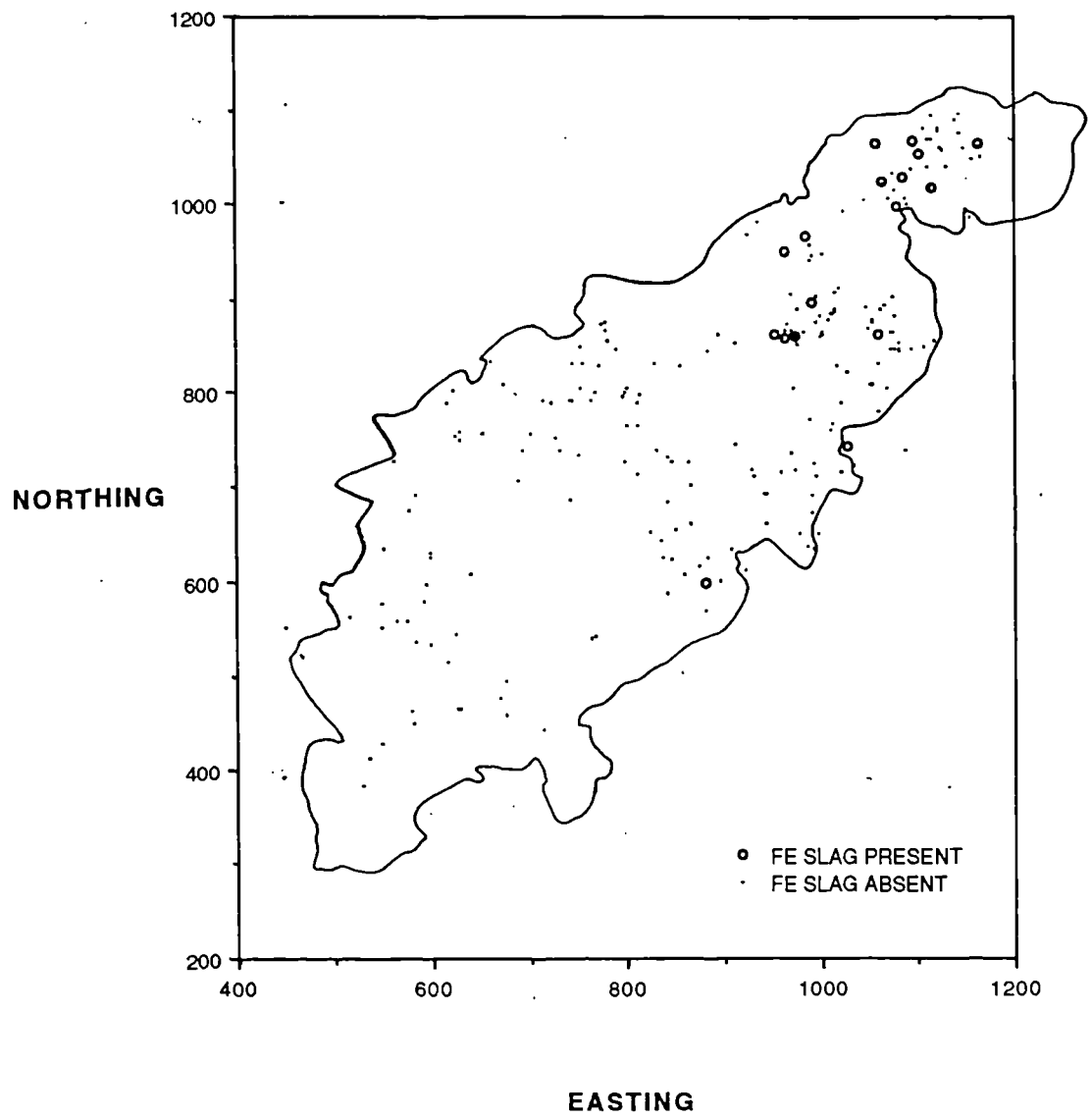

Figure 7.50 Distribution map of all scatters associated with iron slag

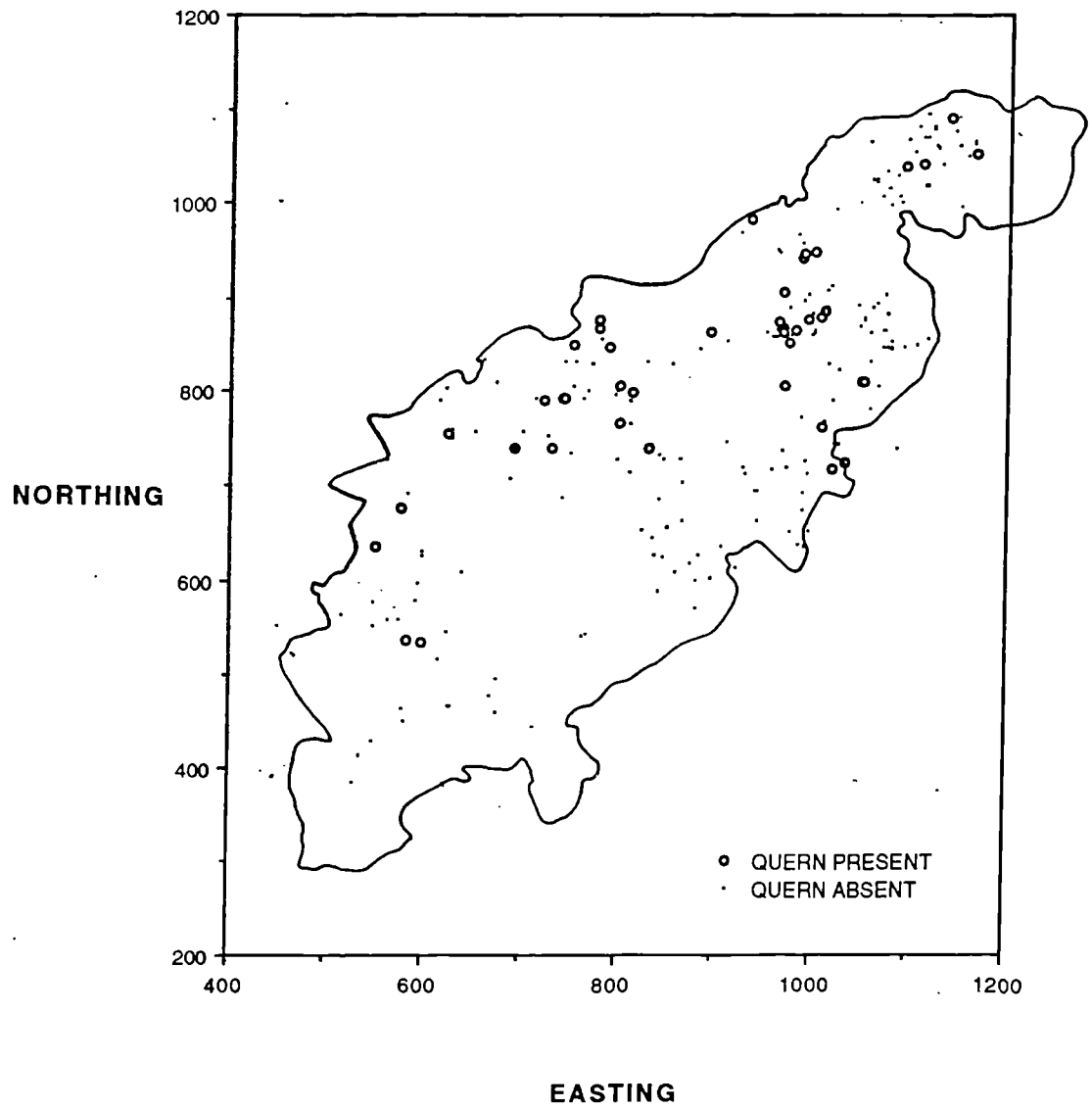

Figure 7.51 Distribution map of all scatters associated with querns

- A) PRELIMINARY SURVEY (REGIONAL)**
 - i) Reconnaissance History
 - ii) Archaeological Visibility & Survival
 - iii) Existing Archaeological Groundwork

- B) MAPPING**
 - i) Area Selection
 - ii) Pre-survey analysis
 - iii) Mapping (units & scales)
 - iv) Mapping Records

- C) ANALYTICAL RECORD**
 - i) Classification Procedure
 - ii) Interpretation Records

- D) INTERPRETIVE MAPS**
 - i) Plots of Selected Sites and Elements
 - ii) Superimposed Groundwork Plots

- E) RECOMMENDATIONS**
 - i) Air Photographic Targeting
 - ii) Excavation - Dating
 - iii) Excavation - Use
 - iv) Ground Based Survey

Figure 8.1 Outline structure of a pilot air photographic survey for Northamptonshire

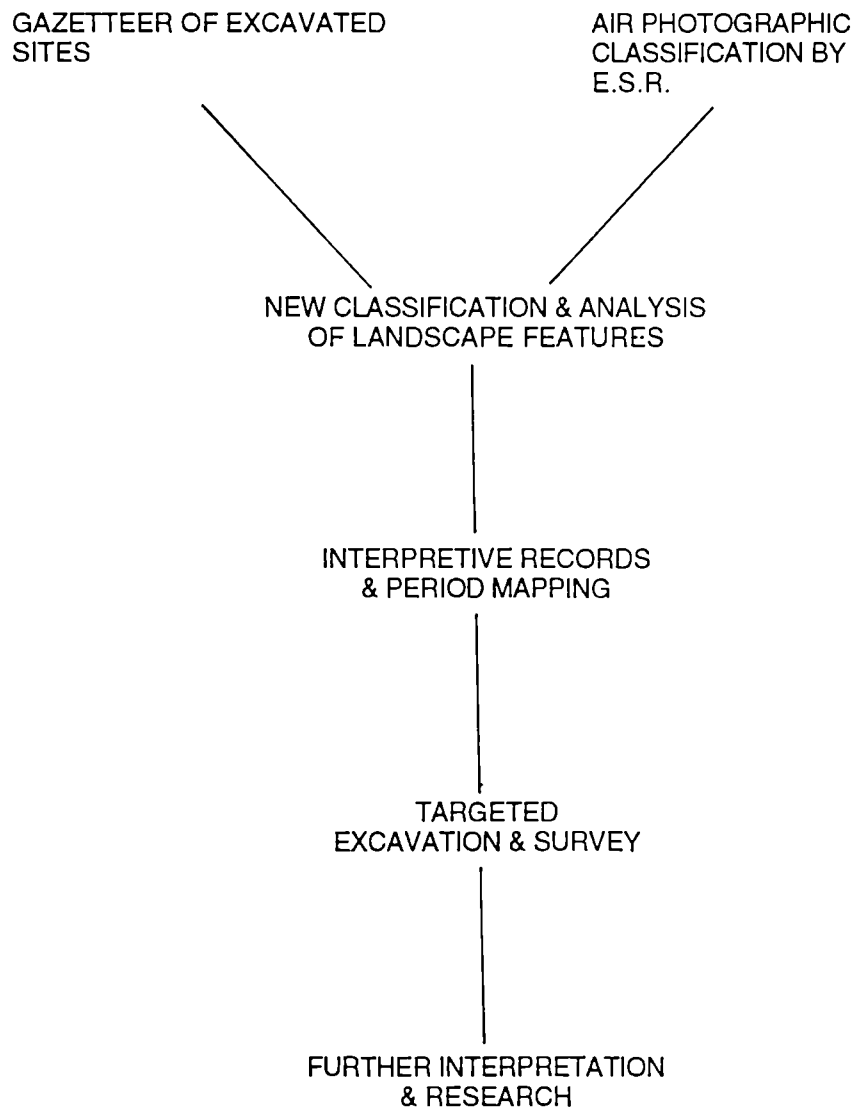

Figure 8.2 An Outline of the air photographic classification procedure for a pilot study.

1 AILSWORTH (VILLA)

Grid ref: TL 109 977
Bibliography: RCHM 1969.

2 ALDWINCLE

Grid ref. SP 995 803
Bibliography: Jackson D.A. 1976a; 1977; Jackson D.A. & Ambrose T.M. 1976; RCHM 1975.

3 APETHORPE

Grid ref: TL 026 949
Bibliography: RCHM 1975.

4 ASHLEY

Grid ref. SP 787 916
Bibliography Taylor S. & Dix B. 1985.

5 ASHTON

Grid ref: TF 048 890
Bibliography: Hadman J.A. & Upex S. 1975; 1976; 1979; Hadman J.A. 1977; 1984; Dix B. 1983; 1984a; 1984b; 1985; Upex S.G. & Hadman J.A. 1978; 1979; Burnham B.C. & Wachter J.S. 1990.

6 BANCROFT I (VILLA)

Grid ref: SP 8273 4033
Bibliography: Mynard D.C. 1987; Williams R.J. & Zeepvat R.J. 1994.

7 BANCROFT II (TEMPLE/MAUSOLEUM)

Grid ref: SP 8253 4058
Bibliography Mynard D.C. 1987; Williams R.J. & Zeepvat R.J. 1994.

8 BARNACK I

Grid Ref. TF 051 069
Bibliography: Donaldson P. 1977; Mackreth D. & O'Neill F. 1979; Cambridgeshire County Council 1992.

9 BARNACK II

Grid ref: TF 081 066
Bibliography: Phillips C.W. 1935; Pryor F.M.M. *et al.* 1985; Simpson W.G. 1993.

10 BARNWELL

Grid ref: TL 073 837
Bibliography: Hadman J.A. & Upex S. 1974a; 1974b; Wild J.P. 1988; Hadman J.A. 1990; Frend W.H.C. & Hadman J.A. 1994

11 BLACKTHORN

Grid ref: SP 804 642
Bibliography Williams J.H. & McCarthy M.R. 1974

12 BOROUGH HILL

Grid Ref: SP 388 626
Bibliography: Edgar W. 1923; RCHM 1981; Jackson D.A. 1995c

13 BOZEAT

Grid ref: SP 896 599
Bibliography: Hall D.N. & Nickerson N. 1969; 1970; Hall D.N. 1971; Meadows I.D. 1993

14 BRIAR HILL I

Grid ref: SP 7362 5923
Bibliography: Bamford H.M. 1976; 1979; 1985

15 BRIAR HILL II

Grid Ref: SP 740 589
Bibliography Jackson D.A. 1974; 1995b; RCHM 1985

16 BRIAR HILL III

Grid Ref: SP 738 588

Bibliography: RCHM 1985; Dix B. & Jackson D.A. 1989; Jackson D.A. 1995b

17 BRIGSTOCK I

Grid ref: SP 961 858

Bibliography: Greenfield E. 1963; 1971; RCHM 1975

18 BRIGSTOCK II

Grid ref: SP 925 841

Bibliography: Jackson D.A. 1983

19 BRIKWORTH

Grid ref: SP 747 719

Bibliography: Mattingly H. 1945; Woods P.J. 1970

20 CAMP HILL

Grid ref: SP 7355 5884

Bibliography: Shaw M. 1979a; Shaw M. & Williams J.H. 1980a

21 CASTOR I (NORMANGATE FIELD)

Grid ref: TL 116 979

Bibliography: Artis E.T. 1828; RCHM 1969; Wild J.P. 1970; 1976b; Dannell G.B. 1974; Wild J.P. & Dannell G.B. 1974a; Dannell G.B. & Wild J.P. 1976; Mackreth D.F. 1979; Perrin J.R. & Webster G. 1990; Burnham B.C. & Wachter J.S. 1990

22 CASTOR II (VILLAGE)

Grid ref: TL 126 986

Bibliography: RCHM 1969; Wild J.P. 1974; Mackreth D.F. 1983; 1984; Green C. *et. al.* 1988**23 COLLEYWESTON**

Grid ref: TF 005 013

Bibliography: Knocker G.M. 1965

24 CORBY

Grid ref: SP 856 868

Bibliography: Jackson D.A. 1982

25 COSGROVE

Grid ref: SP 7947 4212

Bibliography: Quinnell H 1992

26 COTTERSTOCK

Grid ref: TL 033 911

Bibliography: Upex S. 1977a; 1977b; 1991; Challands A. 1992

27 CRICK

Grid Ref: SP 570 726

Bibliography: Gwilt pers. comm.

28 CULWORTH

Grid Ref: SP 544 470

Bibliography: Audouy M. 1995

29 DEANSHANGER

Grid ref: SP 769 396

Bibliography: Woods P.J. 1973; RCHM 1982; Monk L. Undated

30 DRAUGHTON

Grid ref: SP 776 766

Bibliography: Grimes W.F. 1946; 1958; RCHM 1981

31 DUSTON

Grid Ref: SP 730 605

Bibliography: Sharp S. 1871; Mattingly H. 1932; RCHM 1985

3 2 EARLS BARTON (CLAY LANE)

Grid ref: SP 845 625
 Bibliography: RCHM 1979; Windell D. 1982; 1983; 1990

3 3 ECTON

Grid ref: SP 824 654
 Bibliography: Johnston D.E. 1969; RCHM 1979; Holmes M. & Meadows I.D. 1995

3 4 FARTHINGSTONE (CASTLE YARD)

Grid ref: SP 617 563
 Bibliography: RCHM 1981; Knight D. 1988

3 5 FENGATE (CAT'S WATER)

Grid ref: TL 215 990
 Bibliography: RCHM 1969; Cranstone D. 1978; Pryor F.M.M. 1976; 1977; 1979; 1984 Pryor F.M.M. & Cranstone D. 1978

3 6 FENGATE (STOREY'S BAR)

Grid ref: TL 212 990
 Bibliography: RCHM 1969; Pryor F.M.M. 1974; 1984.

3 7 FENGATE (VICARAGE FARM)

Grid ref: TL 208 993
 Bibliography: RCHM 1969; Pryor F.M.M. 1984

3 8 GEDDINGTON

Grid ref: SP 875 826
 Bibliography: Jackson D.A. 1979a

3 9 GREAT DODDINGTON

Grid ref: SP 882 658
 Bibliography: Windell D. 1981; Dix B. & Jackson D.A. 1989

4 0 GREAT OAKLEY I

Grid ref: SP 881 866
 Bibliography: Jackson D.A. 1982

4 1 GREAT OAKLEY II

Grid ref: SP 887 869
 Bibliography: Meadows I.D. 1993

4 2 GREAT WELDON

Grid ref: SP 929 900
 Bibliography: Smith D.J., Hird L. & Dix B 1990

4 3 GRENDON I

Grid Ref: SP 873 617
 Bibliography: McCormick A.G. 1975; RCHM 1979; Gibson A.M. & McCormick A.G. 1985

4 4 GRENDON II

Grid Ref: SP 897 637
 Bibliography: RCHM 1979; Jackson D.A. 1992; No Date

4 5 GRETTON I

Grid ref: SP 908 944
 Bibliography: Jackson D.A. 1979b

4 6 GRETTON II

Grid ref: SP 910 946
 Bibliography: Jackson D.A. 1974; Jackson D.A. & Knight D 1985

4 7 GUILSBOROUGH

Grid Ref: SP 673 728
 Bibliography: RCHM 1981; Cadman G. 1989; Pattison P. & Oswald A. 1995

4 8 HARDINGSTONE

Grid ref: SP 764 574
Bibliography: Woods P.J. 1969; RCHM 1985

4 9 HARROLD

Grid ref: SP 953 573
Bibliography: Eagles B.N. & Evison V.I. 1970; Brown A.E. 1972

5 0 HARTIGANS

Grid ref: SP 851 423
Bibliography: Green H.S. 1993

5 1 HELPSTON

Grid ref: TF 123 042
Bibliography: Dakin G.F. 1969; Challands A. 1975

5 2 HIGHAM FERRERS

Grid ref: SP 954 689
Bibliography: Meadows I.D. 1993

5 3 HUNSBURY

Grid ref: SP 735 583
Bibliography: Dryden H.E.L. 1885; Baker R.S. 1891; Smith R.A. 1912; George T.J. 1917; Fell C.I. 1936; RCHM 1985; Jackson D.A. 1995a; 1995b

5 4 IRCHESTER I

Grid ref: SP 918 664
Bibliography: Hall D.N. & Nickerson N. 1967; RCHM 1979; Burnham B.C. & Wachter J.S. 1990

5 5 IRCHESTER II

Grid ref: SP 922 669
Bibliography: Knight J.K. 1967; Cowley D.E. & Foard G.R. 1979; Windell D. 1984; Burnham B.C. & Wachter J.S. 1990; Dix B. 1992; 1993

5 6 IRTHLINGBOROUGH

Grid Ref: SP 958 715
Bibliography: Dix B. (ed.) 1988

5 7 KETTERING

Grid ref: SP 873 804
Bibliography: Foster P.J. 1976; Taylor S. & Dix B. 1988; Dix B. 1988

5 8 LAXTON

Grid ref: TF 068 971
Bibliography: Jackson D.A. & Tylecote R.F. 1988

5 9 LONGTHORPE I

Grid ref: TL 158 977
Bibliography: RCHM 1969; Wild J.P. 1973a; Frere S.S. & St. Joseph J.K. 1974

6 0 LONGTHORPE II

Grid ref: TL 164 975
Bibliography: RCHM 1969; Wild J.P. 1973a; Dannell G.B. 1975; Dannell G.B. & Wild J.P. 1975; 1987

6 1 LYNCH FARM I

Grid ref: TL 149 977
Bibliography: RCHM 1969; Wild J.P. 1973b; Challands A. 1973; 1974c; Wild J.P. & Dannell G.B. 1974b; Sauvaget R. *et al.* 1975

6 2 LYNCH FARM II

Grid ref: TL 145 976
Bibliography: RCHM 1969; Jones R.F.J. 1973; 1975

6 3 MAXEY (BARDYKE FIELD)

Grid ref: TF 125 077
Bibliography: Simpson W.G. 1985

6 4 MAXEY (EAST & WEST FIELDS)

Grid ref: TF 1280 0770
Bibliography: Pryor F.M.M. *et al.* 1985

6 5 MAXEY (OS 124)

Grid ref: TF 126 075
Bibliography: Simpson W.G. 1981

6 6 MAXEY (PLANTS FARM)

Grid ref: TF 115 080
Bibliography: Gurney D.A. *et al.* 1993b

6 7 MILEOAK

Grid ref: SP 667 477
Bibliography: Green C. & Draper J. 1978

6 8 MOULTON PARK

Grid ref: SP 775 645
Bibliography: Williams J.H. & Mynard D.C. 1974; Shaw T.M. 1979b

6 9 ODELL

Grid ref: SP 956 568
Bibliography: Dix B. 1978; 1979; 1980; 1981

7 0 ORTON LONGUEVILLE (HALL FARM)

Grid ref: TL 176 056
Bibliography: Dakin G.F. 1960; RCHM 1969; Mackreth D.F. 1974; 1976; 1977a; 1977b; 1978

7 1 ORTON LONGUEVILLE (MONUMENT 97)

Grid ref: TL 1665 9525
Bibliography: RCHM 1969; Dallas C. 1975a; 1975b; 1975c

7 2 OVERSTONE

Grid ref: SP 805 646
Bibliography: Williams J.H. 1976

7 3 PENNYLAND

Grid ref: SP 862 411
Bibliography: Williams R.J. 1993

7 4 PIDDINGTON

Grid ref: SP 7965 5400
Bibliography: Friendship-Taylor R.M. *et al.* 1981; Friendship-Taylor R.M. & Friendship-Taylor D.E. 1986; 1989a; 1989b; 1993a; 1993b; 1996

7 5 QUINTON

Grid ref: SP 7755 5368
Bibliography: Taylor R.M. 1974; Friendship-Taylor R.M. 1974; 1975a; 1975b; 1976; 1977; 1979a; 1979b

7 6 RAINSBOROUGH

Grid ref: SP 526 348
Bibliography: Avery M., Sutton J.E.G. & Banks J.W. 1967

7 7 REDLANDS FARM

Grid ref: SP 959 705
Bibliography: Moore J. & Jackson D.A. 1990; Keevil, G.D. 1990; 1991; 1992a; 1992b

7 8 RINGSTEAD I

Grid ref: SP 977 748
Bibliography: Jackson D.A. 1980

7 9 RINGSTEAD II (TOP LODGE)

Grid ref: SP 9820 7379
Bibliography: Shaw M. & Blinkhorn P. 1993

8 0 RUSHDEN

Grid ref: SP 943 663
Bibliography: Woods P.J. & Hastings S. 1984

8 1 SACREWELL

Grid Ref: TF 077 005
Bibliography: Challands A. 1974a; 1974b

8 2 STANTONBURY

Grid ref: SP 8443 4123
Bibliography: Mynard D. 1987

8 3 STANTON LOW

Grid ref: SP 842 430
Bibliography: Woodfield C. 1989

8 4 STANWELL SPINNEY

Grid ref: SP 870 694
Bibliography: Dix B. & Jackson D.A. 1989

8 5 STANWICK

Grid ref: SP 972 716
Bibliography: Foard G. & Pearson T. 1985; Neal D.S. 1986; 1988a; 1988b; 1989; 1991; 1992

8 6 STIBBINGTON

Grid ref: TL 085 986
Bibliography: Wild J.P. 1973c.

8 7 STRIXTON

Grid ref: SP 894 618
Bibliography: RCHM 1979; Hall D.N. 1971; Hall D.N. & Nickerson N. 1969

8 8 TALLINGTON

Grid ref: TF 103 090
Bibliography: Peacock D.P.S. 1962; Simpson W.G. 1966; Gurney D.A. *et al.* 1993a

8 9 THORPLANDS

Grid ref: SP 7893 6506
Bibliography: Hunter R. & Mynard D. 1977

9 0 THRAPSTON

Grid ref: TL 002 782
Bibliography: RCHM 1975; Jackson D.A. 1993

9 1 TOWCESTER (ALCHESTER ROAD)

Grid ref: SP 688 485
Bibliography: Woodfield C. 1978; Brown A.E. & Woodfield C. 1983; Burnham B.C. & Wachter J.S. 1990

9 2 TOWCESTER (DEFENCES)

Grid ref: SP 689 486
Bibliography: Woodfield C. 1978; 1993; Burnham B.C. & Wachter J.S. 1990

9 3 TOWCESTER (GRAMMAR SCHOOL)

Grid ref: SP 6900 4880
Bibliography: Brown A.E. & Alexander J.A. 1982; Burnham B.C. & Wachter J.S. 1990

94 TOWCESTER (PARK STREET)

Grid ref: SP 693 488

Bibliography: Lambrick G. 1977b; 1980b; Burnham B.C. & Wacher J.S. 1990

95 TOWCESTER (WOOD BURCOTE)

Grid ref: SP 685 469

Bibliography: Turland R.E. 1977

96 TWYWELL

Grid ref: SP 952 787

Bibliography: Jackson D.A. 1975

97 UPTON

Grid ref: SP 713 602

Bibliography: Jackson D.A., Harding D.W. & Myres J.N.L. 1969

98 WAKERLEY I

Grid ref: SP 941 983

Bibliography: Jackson D.A. & Ambrose T.M. 1978

99 WAKERLEY II (HARRINGWORTH/WAKERLEY)

Grid ref: SP 935 979

Bibliography: Jackson D.A. 1981

100 WALTON (WAVENDON GATE)

Grid Ref: SP 903 369

Bibliography: Mynard D.C. & Woodfield C. 1977; Williams R.J. 1990

101 WEEKLEY

Grid ref: SP 884 817

Bibliography: RCHM 1979; Jackson D.A. & Dix B. 1988

102 WEEKLEY HALL WOOD

Grid ref: SP 874 813

Bibliography: Jackson D.A. 1976b

103 WERRINGTON

Grid ref: TF 1664 0386

Bibliography: RCHM 1969; Mackreth D.F. & O'Neill F. 1980; O'Neill F. 1980; Mackreth D.F. 1988

104 WHILTON LODGE (BANNAVENTA)

Grid ref: SP 612 645

Bibliography: RCHM 1981; Dix B. & Taylor S. 1988

105 WHITTLEBURY

Grid ref: SP 732 456

Bibliography: RCHM 1982

106 WOLLASTON (BYPASS)

Grid ref: SP 9025 6250

Bibliography: Chapman A. & Jackson D.A. 1993

107 WOOLLASTON QUARRY

Grid ref: SP 895 636 - SP 899 645

Bibliography: Meadows, I.D. 1993; pers. comm.

108 WOLLASTON

Grid Ref: SP 909 641

Bibliography: Hall D.N. 1970

109 WOLLASTON

Grid Ref: SP 884 636

Bibliography: Meadows I.D. pers comm.

110 WOLLASTON

Grid Ref: SP 879 629

Bibliography: Meadows I.D. & Jackson D.A. pers. comms.

111 WOOTTON HILL FARM

Grid ref: SP 738 578

Bibliography: Jackson D.A. 1990

112 WOOTTON VILLA

Grid Ref: SP 736 582

Bibliography: Williams J.H. & Shaw M. 1980; 1981; Shaw M. & Williams J.H. 1980b; Williams J.H. 1982; RCHM 1984

113 WOUGHTON

Grid ref: SP 8615 3774

Bibliography: Mynard D. 1987

114 WYMBUSH

Grid ref: SP 8285 3893

Bibliography: Mynard D. 1987

APPENDIX 2 THE CLASSIFICATION AND RECORDING OF THE FIELDWALKED POTTERY

Introduction

The pottery studied for chapter 7 was recovered from a very diverse and extensive region and covered a considerable date range. For the purposes of the study some way had to be devised to synthesise this information such that it could be managed effectively and studied critically. It was decided to construct an archive for the pottery that consisted of three main elements. The first was a catalogue of the macroscopic fabric descriptions of the pottery. These were carried out using a 10x magnifying lens and a standardised recording sheet. Although descriptions of fabrics may vary considerably between researchers it was hoped that some degree of cross-referencing would be possible if the definition of certain terms were made explicit.

The fabric classifications were intended to form the basic structure of the archive as they provide information on the method of production and possible provenance of the pottery. In order to carry out further study however, it was important to attempt to cross-reference the fabrics to sources or at least commonly known 'wares'. This term allows us to group pottery into commonly recognised form and fabric classifications which are linked to a source (be that a kiln group or broad region), a distinctive manufacturing technique and/or at least a broad chronological period. For these purposes three main sources were used for reference: the fabric archive held by Northamptonshire Archaeology (formerly the Northamptonshire Archaeology Unit), the catalogue produced by Pauline Marney for her work at Towcester and Milton Keynes (cf. Brown & Alexander 1982; Brown & Woodfield 1983; Marney 1989), and for the iron age the classificatory scheme used by Knight (cf. 1984; Williams 1993). This process of grouping the fabrics into wares produced the 33 fabric groups used in the case study. The link between these groups and the fabrics used in the original quantified record sheets held on archive is listed below alongside a common name used for their identification. For a full assessment of the fabric archive and dating the reader is referred to the archive held by the author.

Cross referencing between Fabric records and fabric groups used for analysis

Ware No.	Fabrics	Name
1	4.1a, 4.1b	Lower Nene Valley Greywares
2	14, 14.1	Lower Nene Valley cream coloured and painted wares
3	4.1c, 5.8	Lower Nene Valley cream coloured and painted wares
4	5.2, 5.6, 5.7	Lower Nene valley mortaria
5	4.10, 9, 9.4, 9.5, 9.8, 9.9, 10	Early grog tempered wares
6	9.6, 9.7	Soft pink grogged wares
7	4.2	Upper and middle Nene greywares
8	16	Early Roman oxidised fabrics
9	4.2b, 4.5b	Early Upper Nene greywares
10	5.9, 27	Oxidised Oxfordhire wares
11	5.5	Oxfordhire colour coated wares
12	9.1	Early fine grog/shell tempered wares
13	4.3, 4.8	Late Roman greywares
14	24.5	Late Roman sandy oxidised ware
15	24.2	Black Burnished Ware 1
16	9.2, 9.3	Second century grogged wares
17	5.3, 5.4	Mancetter Hartshill mortaria
18	5.1	Lincolnshire mortaria
19	15.1	South and central Gaulish Samian
20	15	East Gaulish Samian
21	3.1, 3.8	Later Harrold shelly wares
22	3.6	Cambridgeshire shelly wares
23	3.7, 3.10, 3.11, 3.12, 8.1	Early shell tempered wares
24	4.2c, 4.4, 4.11, 25	Second century sandy greywares
25	4.5, 4.6, 4.7, 6.1, 24, 4.4b, 10.3	Mid Roman greywares

26	4.9, 10.1, 10.2	South/central Northamptonshire sandy wares
27	12.1, 12.2, 12.3, 5.10	White /cream sandy wares
28	3.2, 3.3, 3.5, 3.9, 7.1, 17, 18.2, 21, 21.1, 21.2, 21.3, 23	Other shell tempered wares
29	28	Spanish amphorae
30	13, 18, 18.1, 19, 20, 22	Early-Middle Saxon wares
31	11	Early Harrold wares
32	21.4, 21.5	Hand made iron age wares
33	24.1, 24.3, 24.4	Second century quartz tempered wares

APPENDIX 3: CALIBRATED C-14 DATES FROM THE REGION

This section contains the radiocarbon dates used in determining the approximate date ranges for the five ceramic groups selected for the studies in chapter 6. They are listed in order of their uncalibrated date from earliest to latest. Each date was calibrated using the OxCal software (Stuiver & Kra 1986) and a calibration diagram produced. Each diagram displays the calibrated date estimates at one and two sigma to the nearest ten years. Below is a list of the dates with their laboratory codes and bibliographic reference.

Date	Code	Reference
Fengate f488	HAR 773	Pryor 1984
Gt. Oakley f9	HAR 4494	Jackson 1982
Gt. Oakley f28	HAR 4064	Jackson 1982
Hunsbury 2	HAR 10569	Jackson 1995a
Gretton A1	HAR 3015	Jackson 1979b
Gretton A2	HAR 2760	Jackson 1979b
Hunsbury 1	HAR 10568	Jackson 1995a
Bancroft 1	UB 3234	Williams & Zeepvat 1994
Pennyland 1	HAR 4852	Williams 1993
Bancroft 2	UB 3233	Williams & Zeepvat 1994
Hunsbury 3	HAR 10570	Jackson 1995a
Hartigans 1	HAR 872	Green 1993
Fengate f1551	HAR 3196	Pryor 1984
Fengate f3	GaK 4198	Pryor 1984
Fengate f6	UB 822	Pryor 1984
Pennyland 2	HAR 4853	Williams 1993
Gretton B1	HAR 3104	Jackson 1979b
Twywell	NPL 225	Jackson 1975
Gretton B2	HAR 2761	Jackson 1979b
Ringstead	HAR 1664	Jackson 1980

Weekley 1	HAR 2007	Jackson & Dix 1988
Weekley 2	HAR 1844	Jackson & Dix 1988
Hartigans 2	HAR 873	Green 1993
Odell 1	HAR 2853	Knight 1984
Weekley 3	HAR 1725	Jackson & Dix 1988
Odell 2	HAR 2851	Knight 1984
Weekley 4	HAR 2008	Jackson & Dix 1988
Odell 3	HAR 2913	Knight 1984
Weekley 5	HAR 1779	Jackson & Dix 1988

M. Stuiver and R.S. Krauss 1986 Radiocarbon 28(2B): 805-1030; OxCal v2.18 cub r4 sd 12 prob[chron]

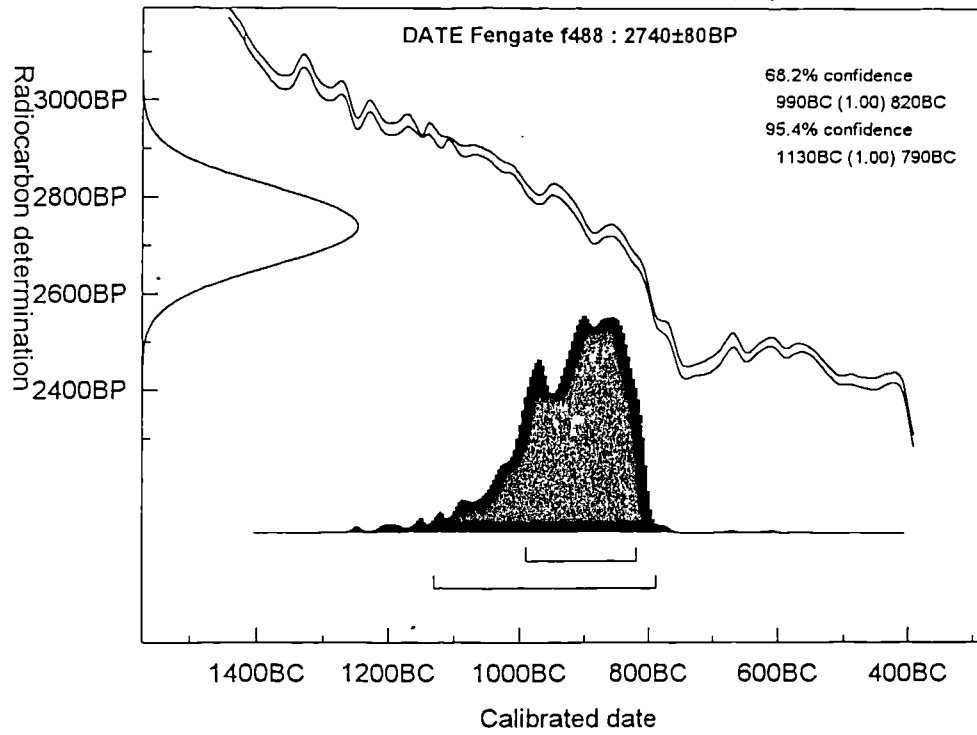

M. Stuiver and R.S. Krauss 1986 Radiocarbon 28(2B): 805-1030; OxCal v2.18 cub r4 sd 12 prob[chron]

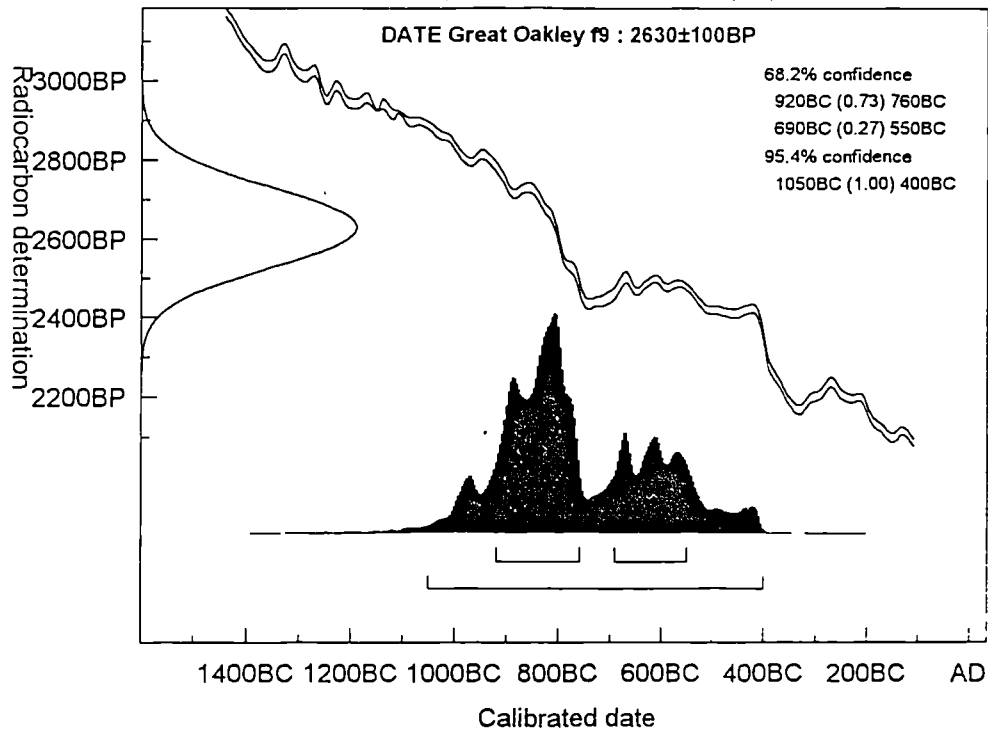

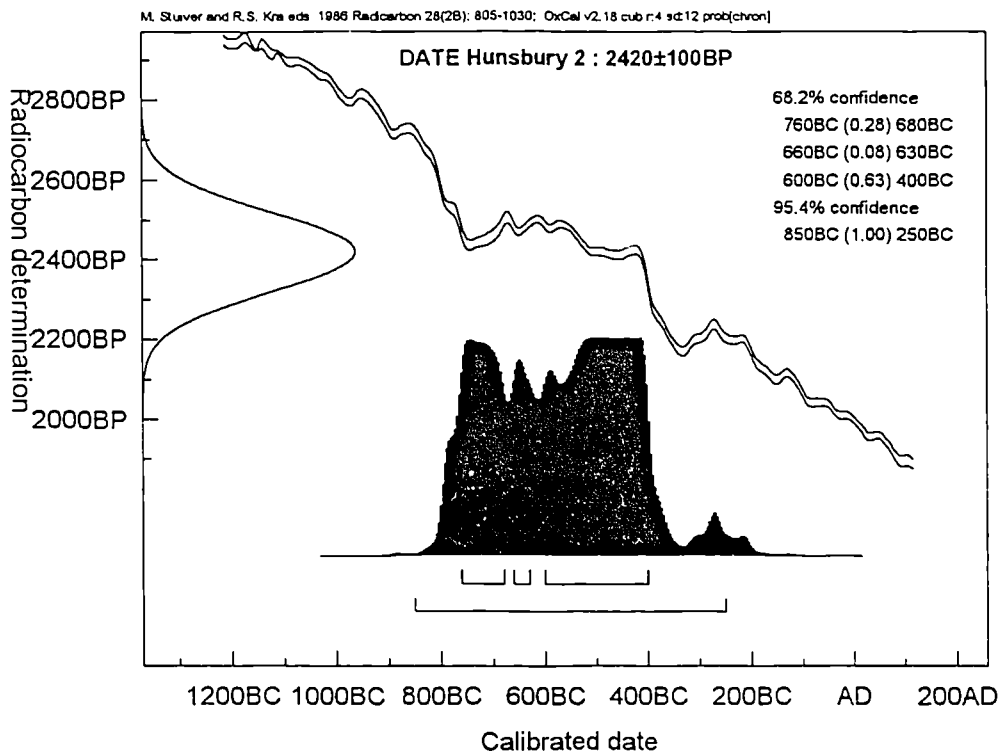
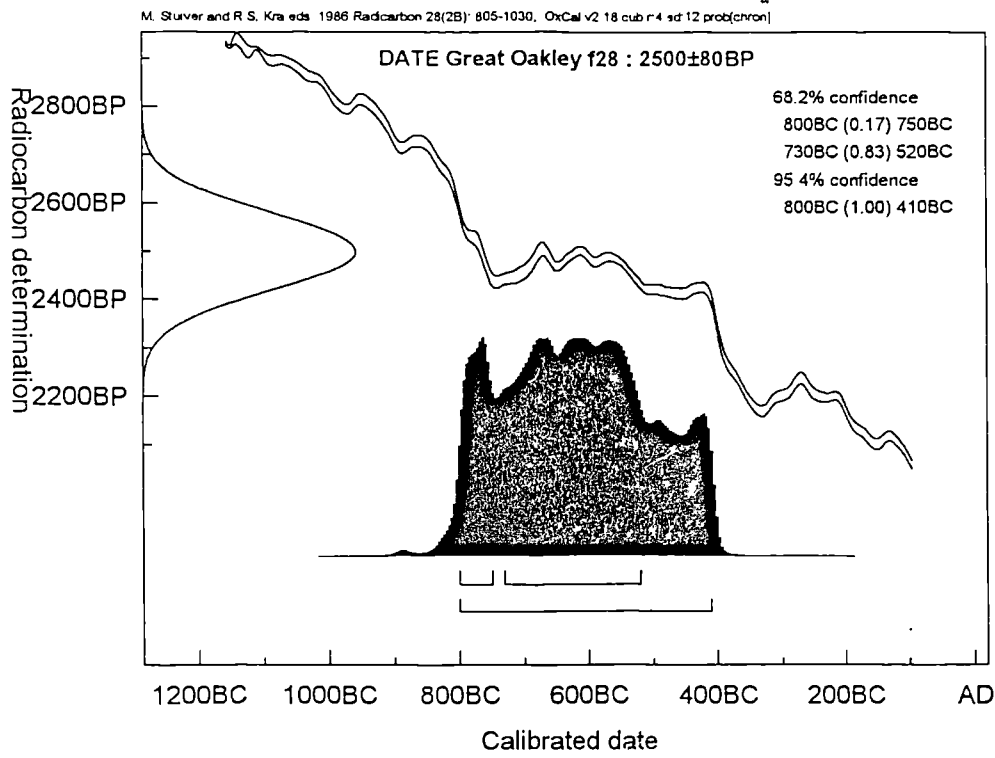

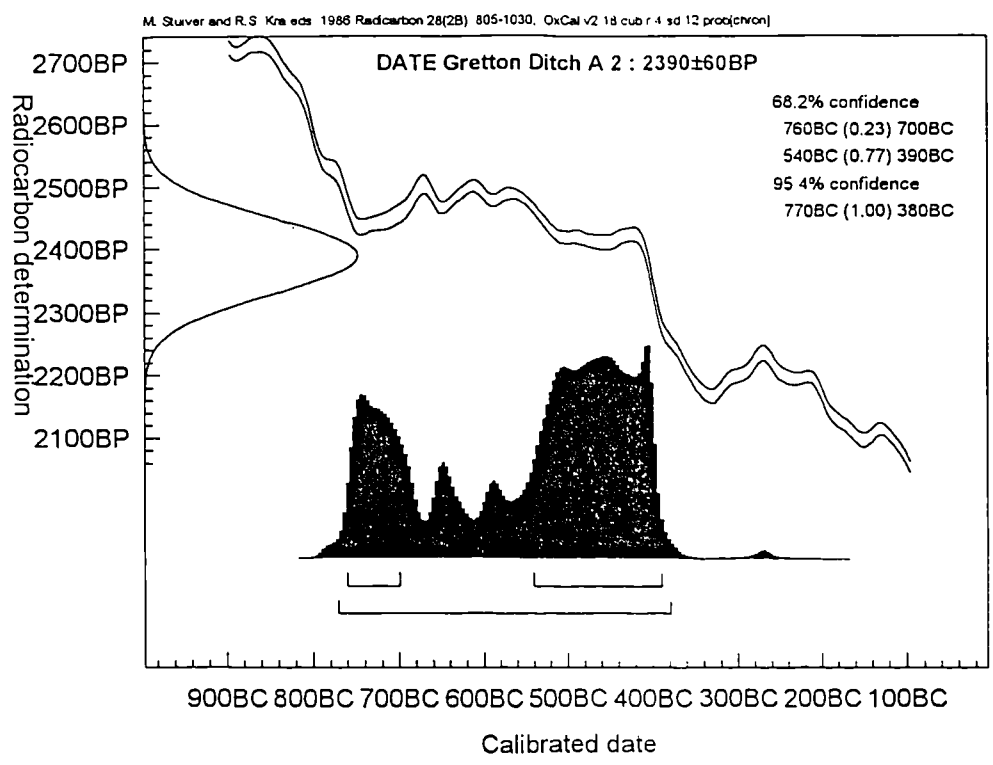
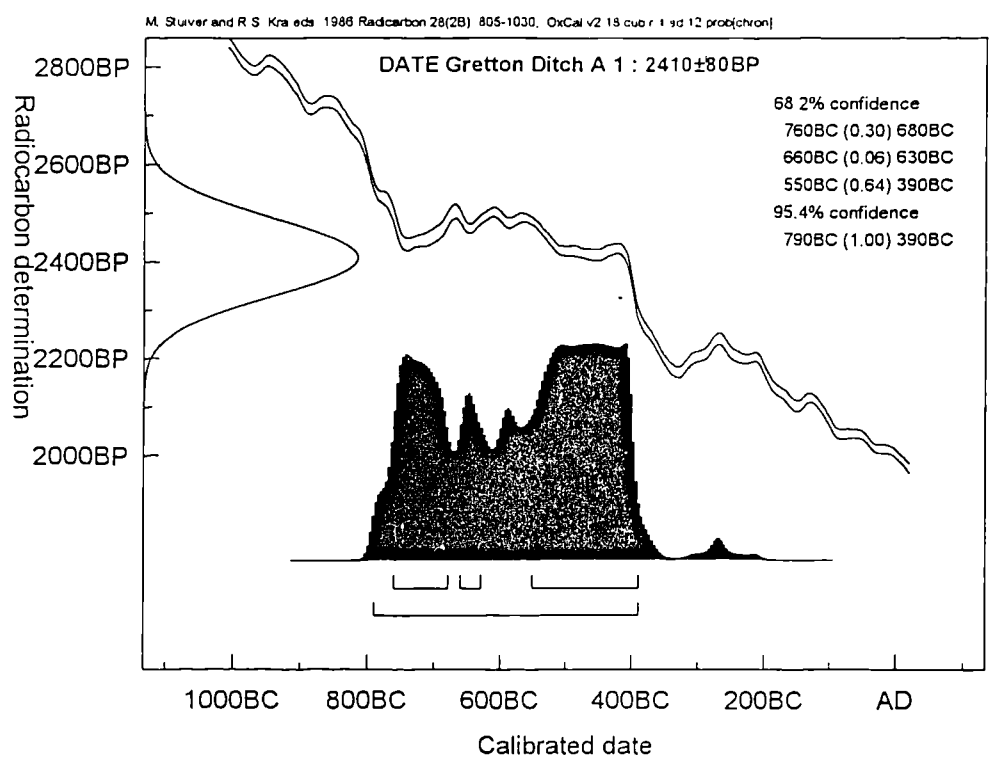

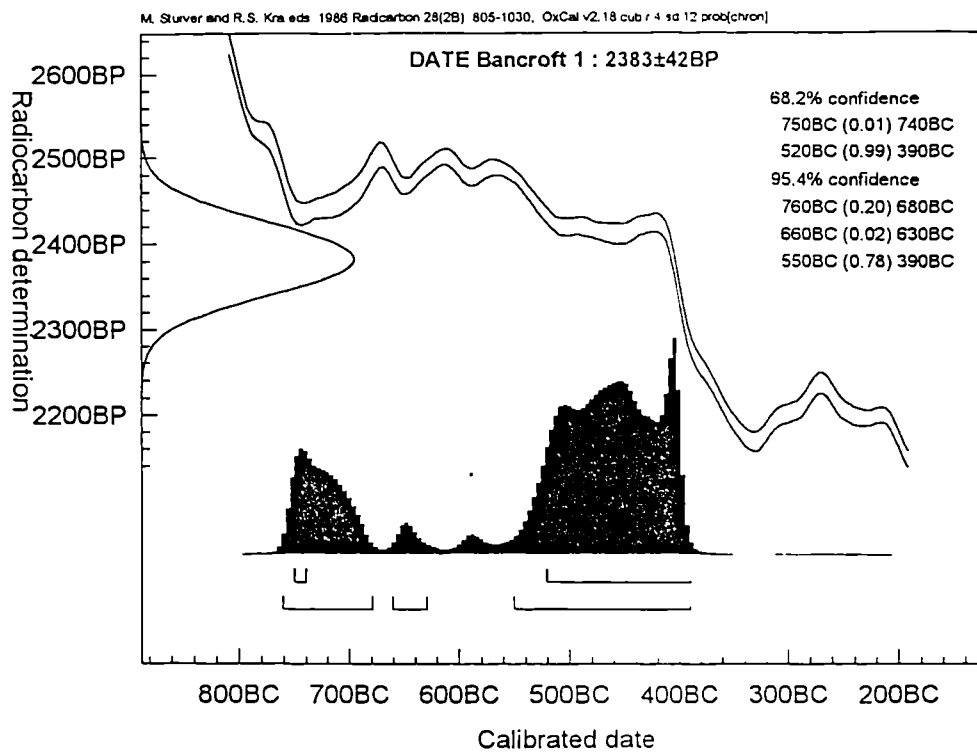
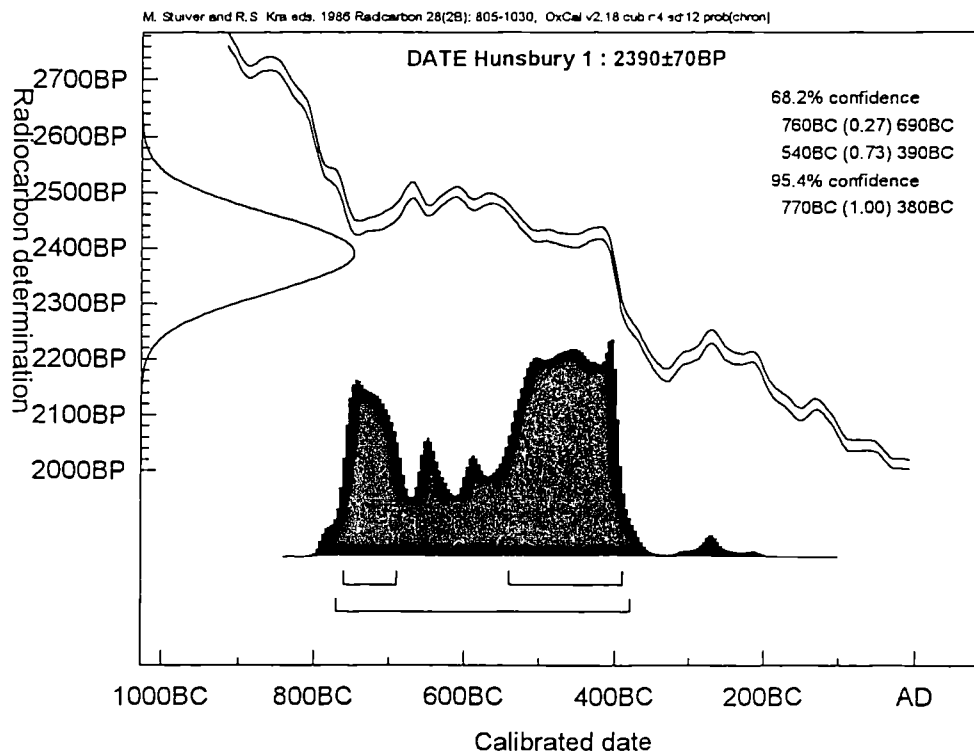

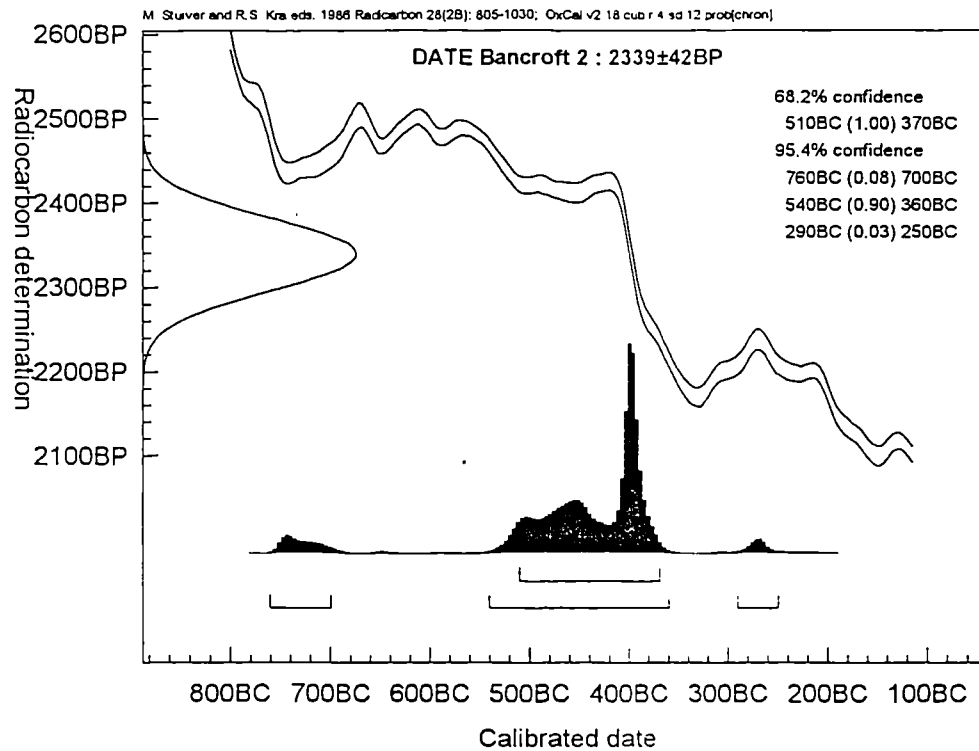
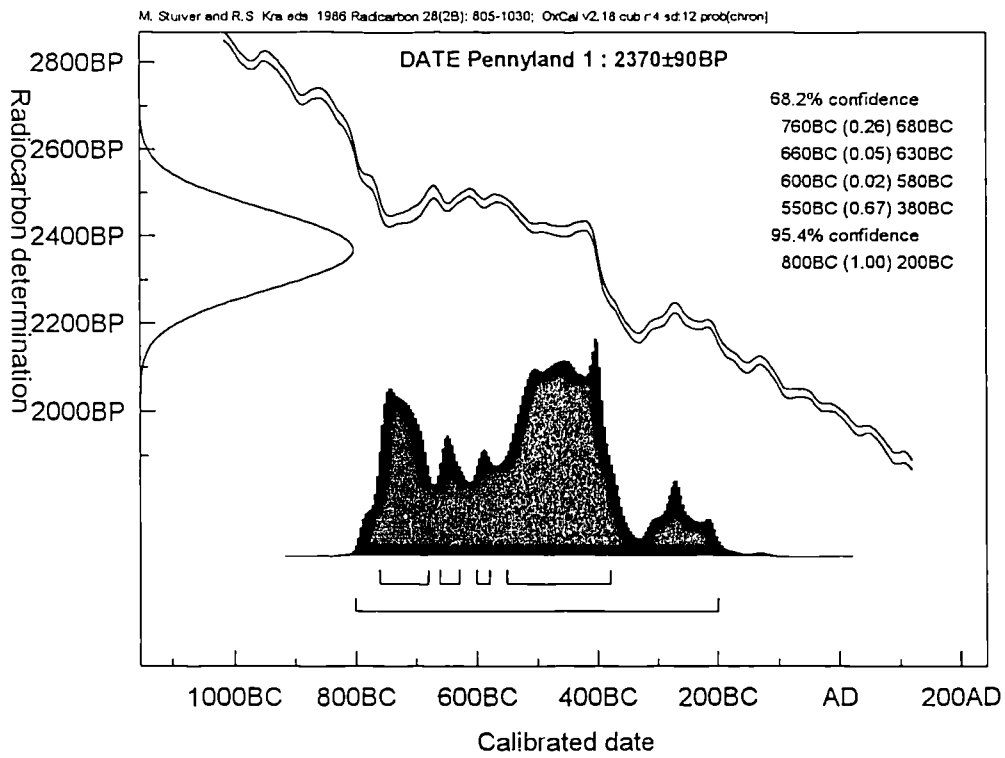

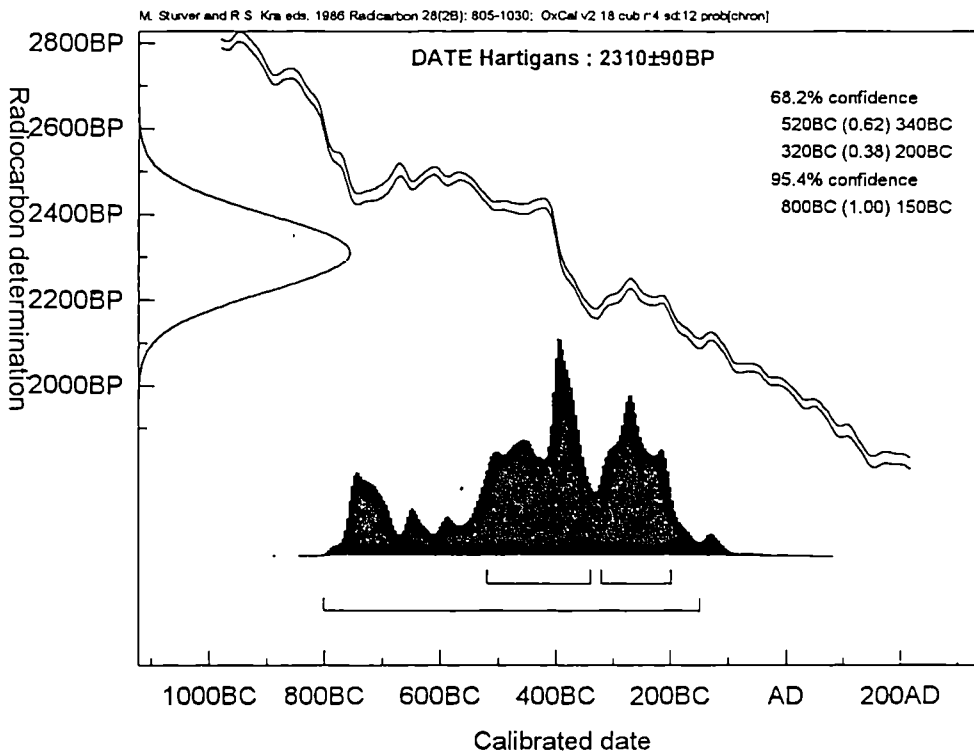
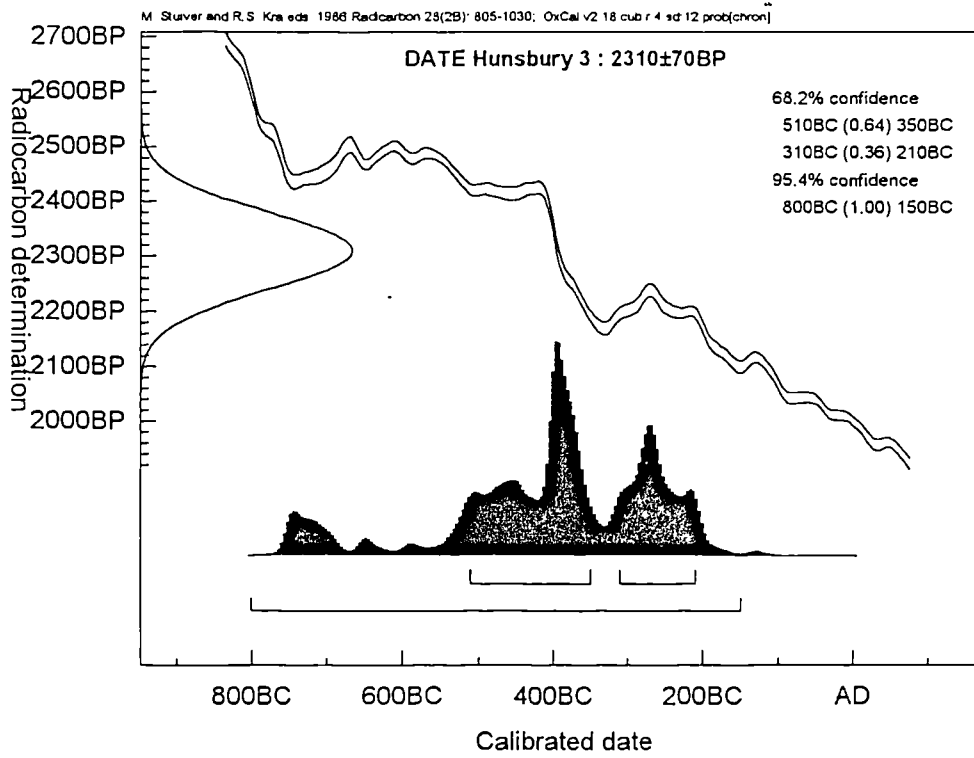

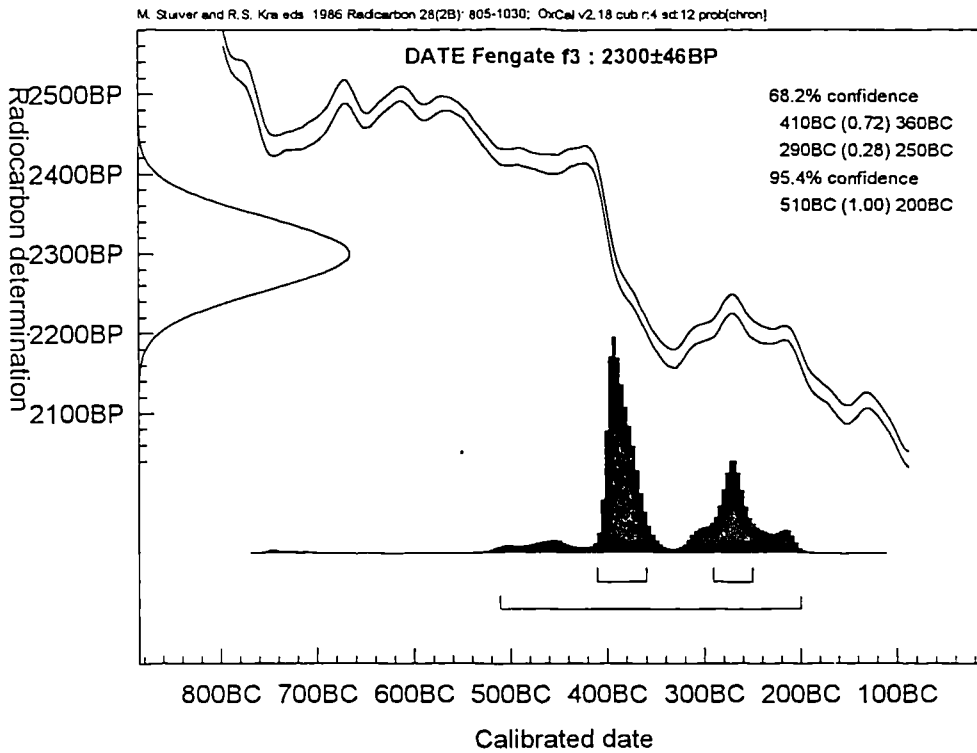
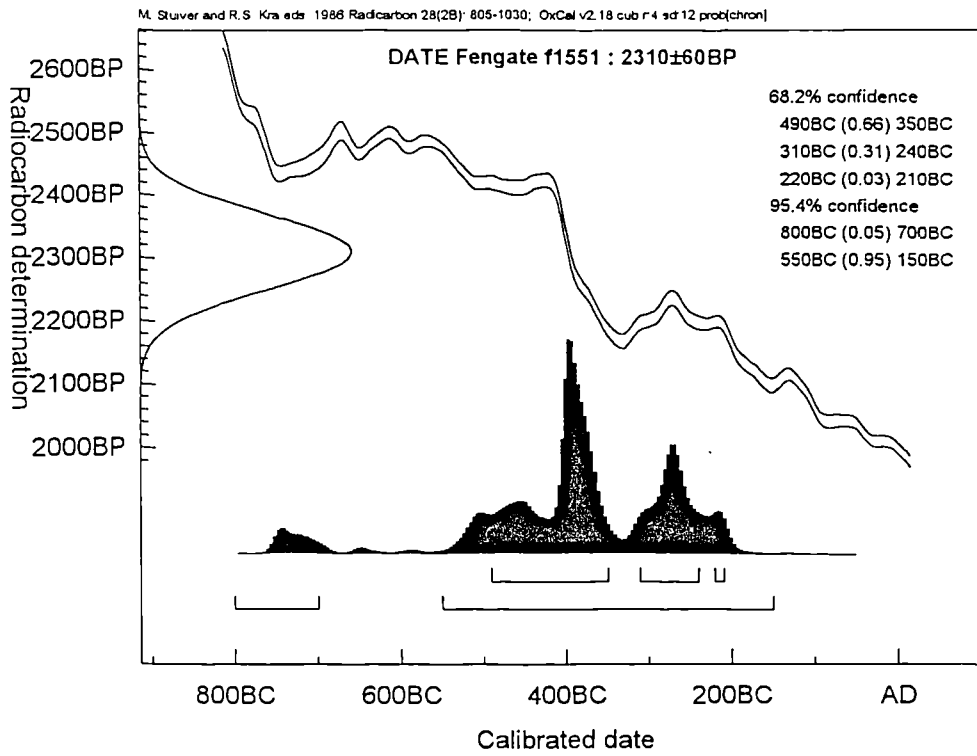

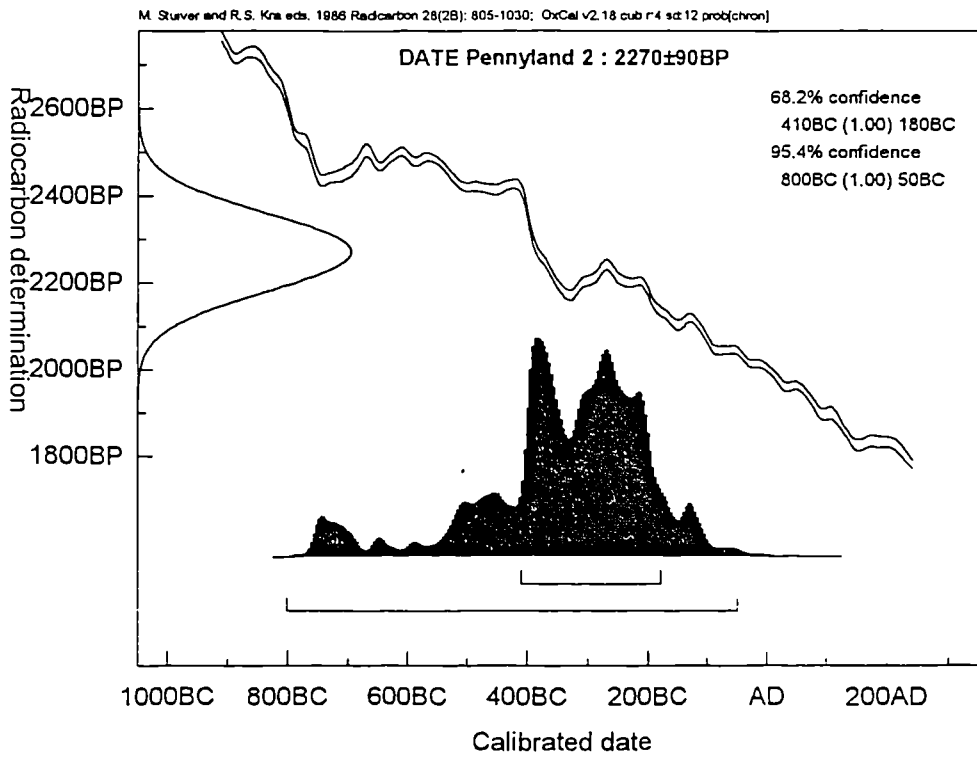
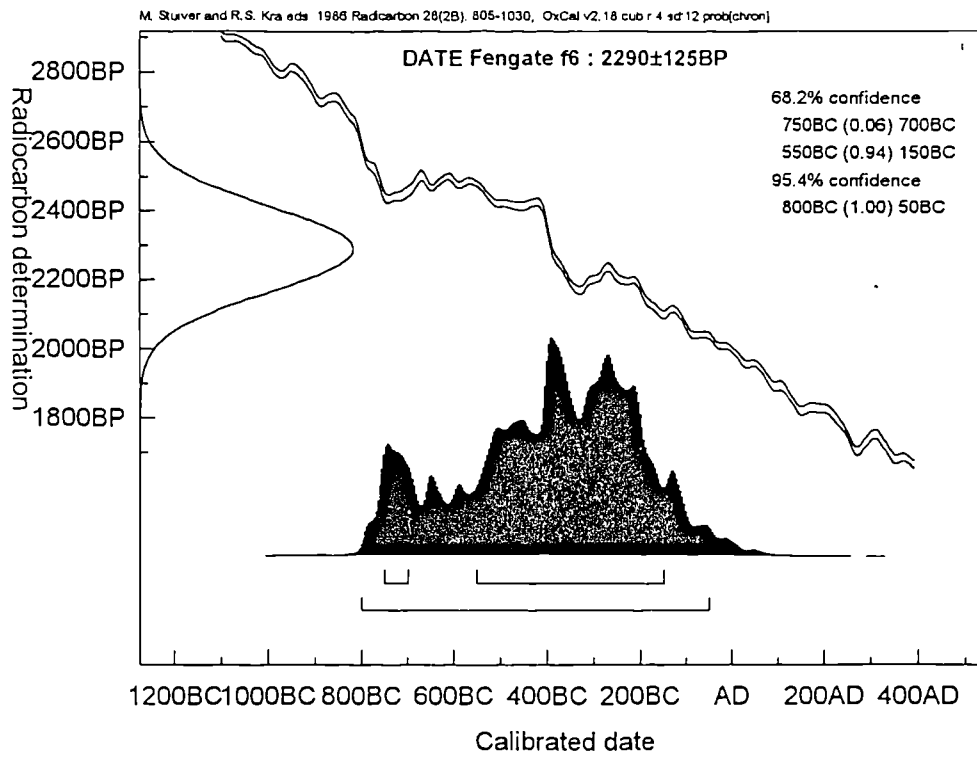

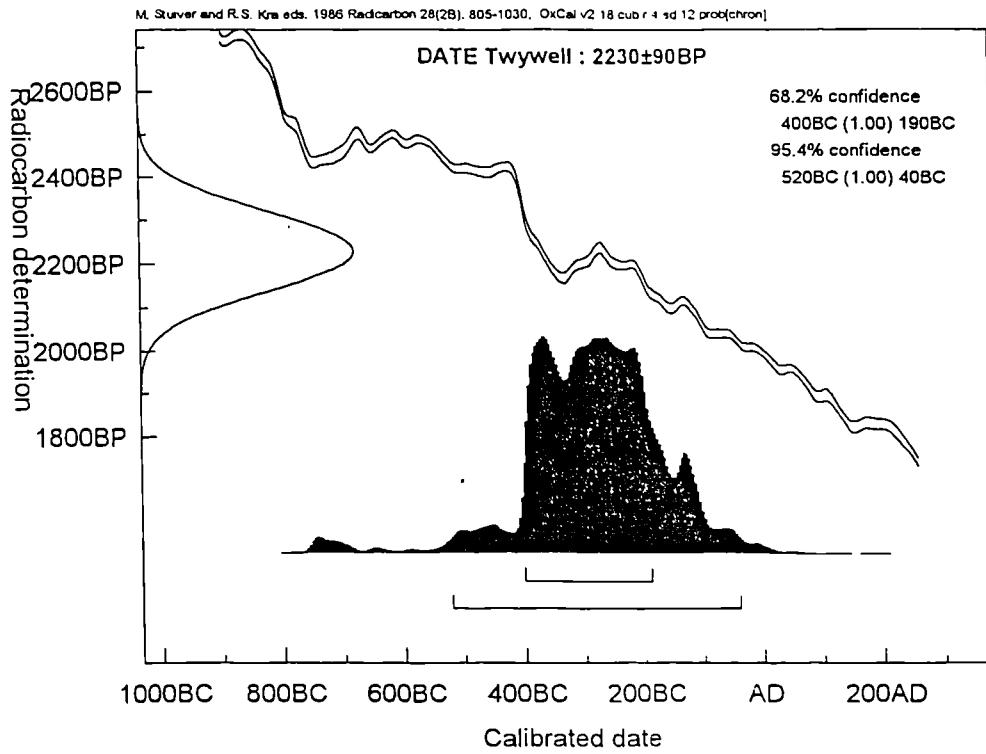
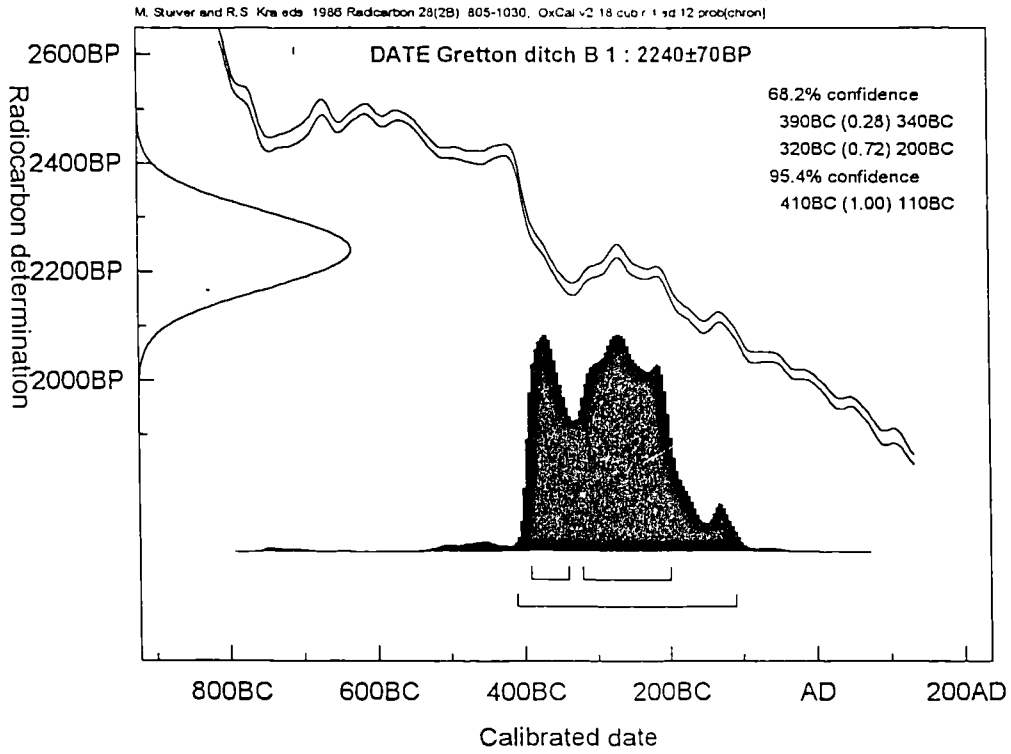

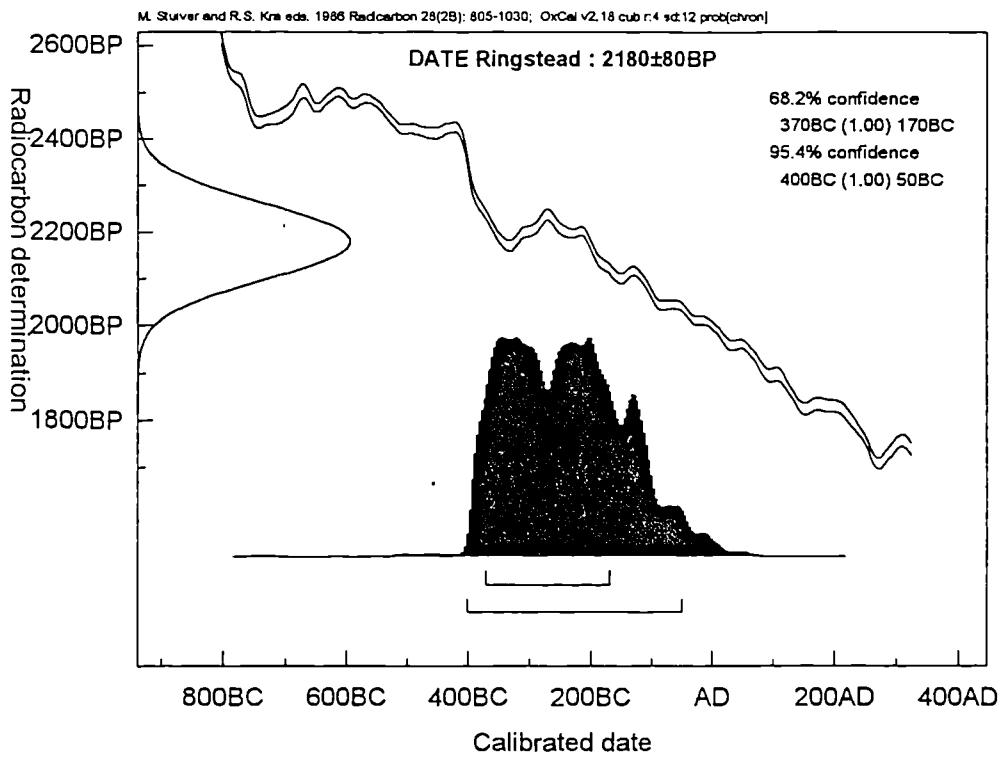
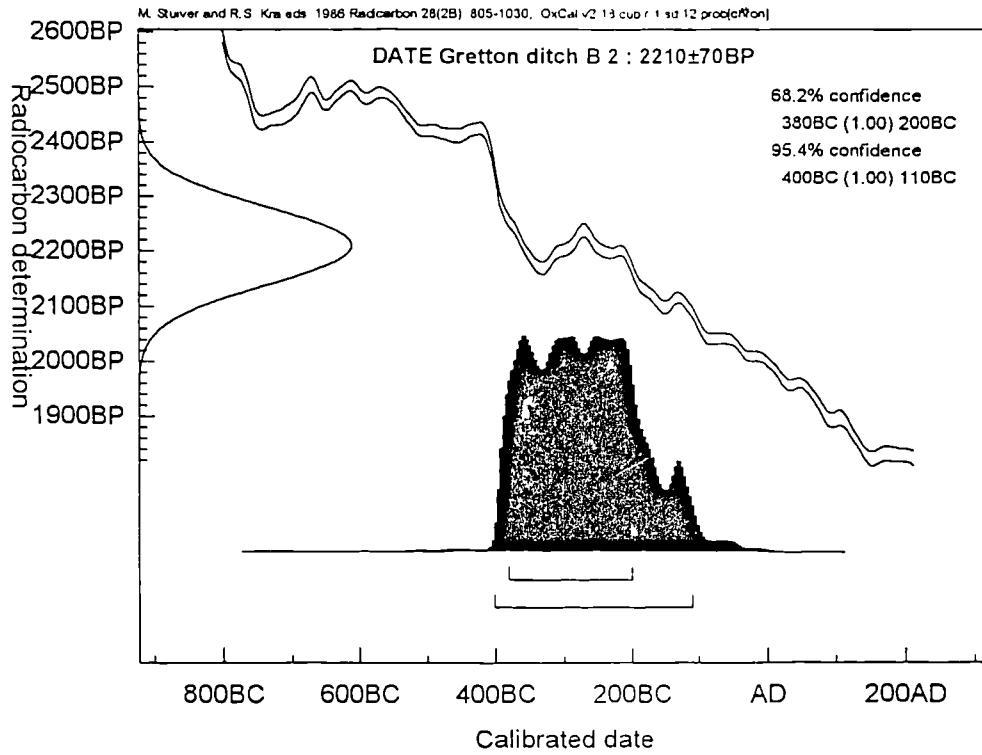

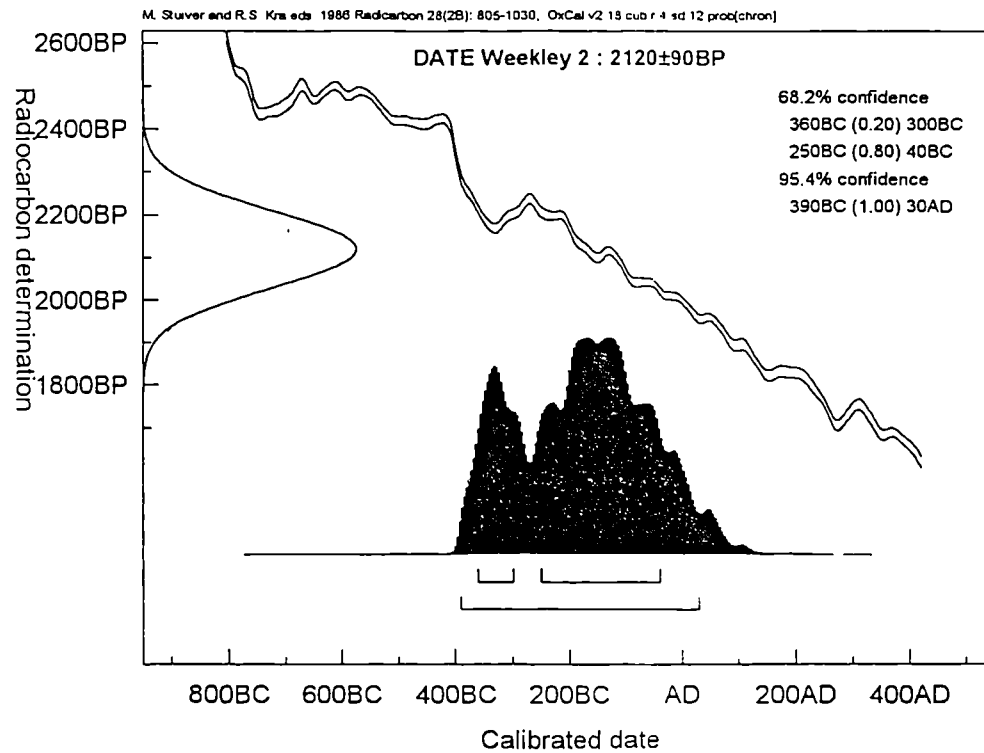
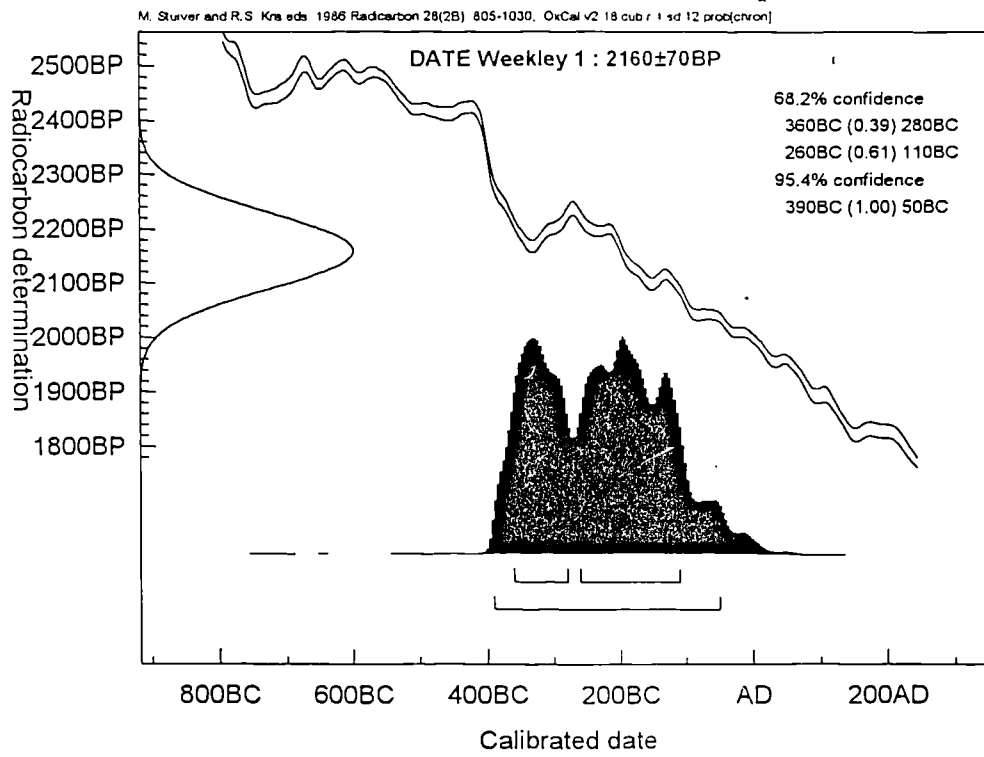

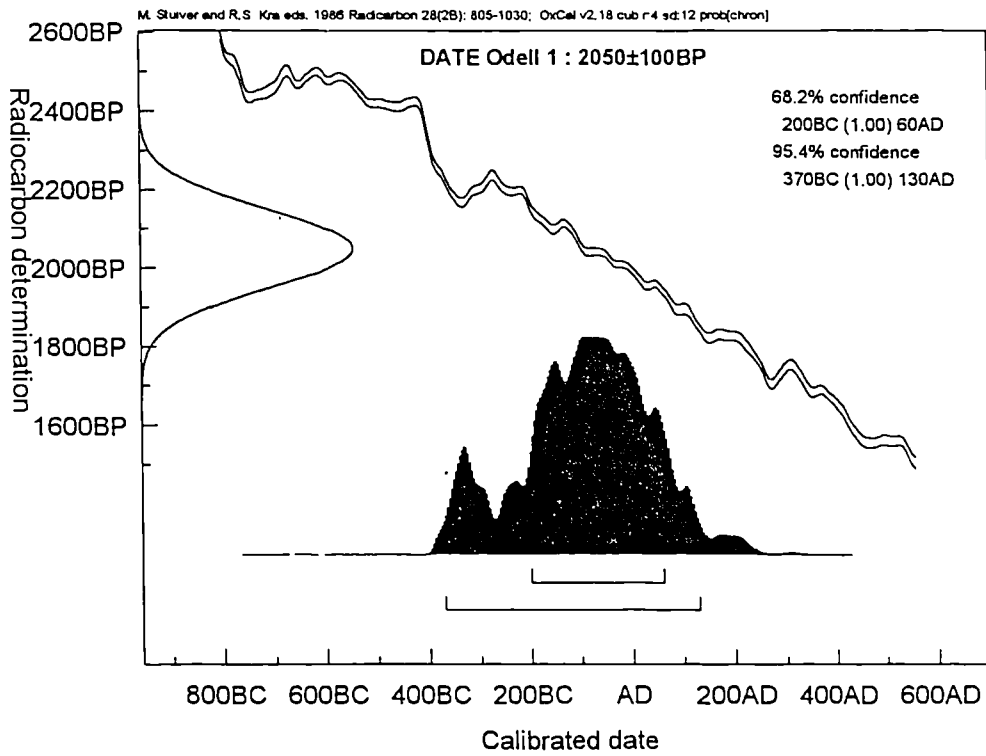
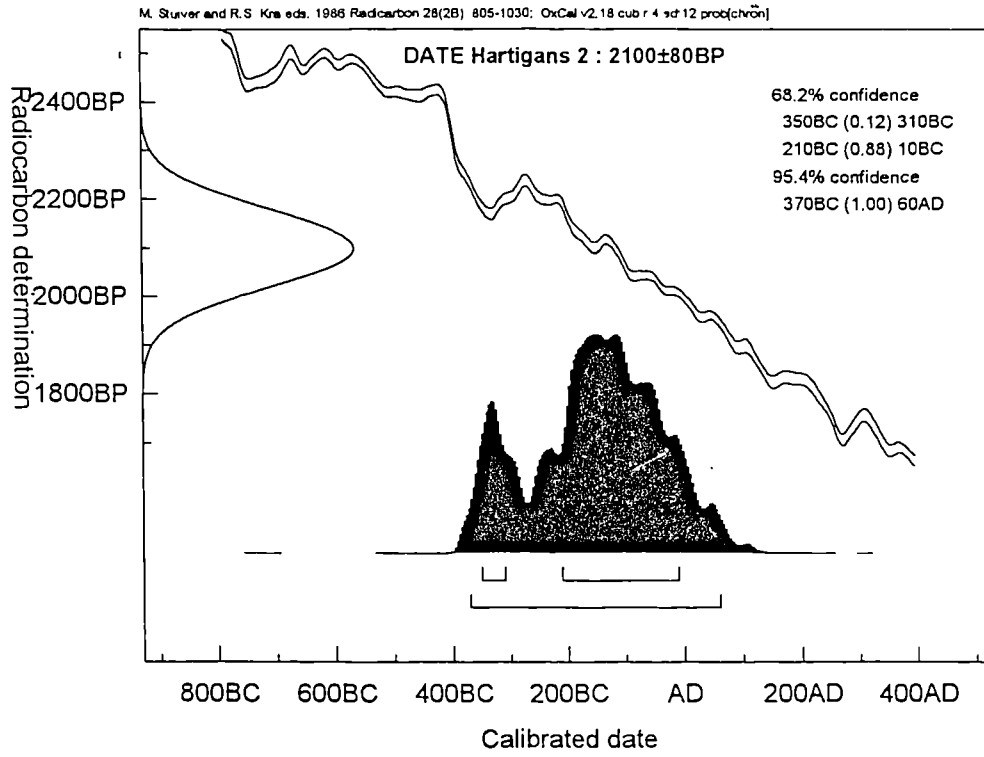

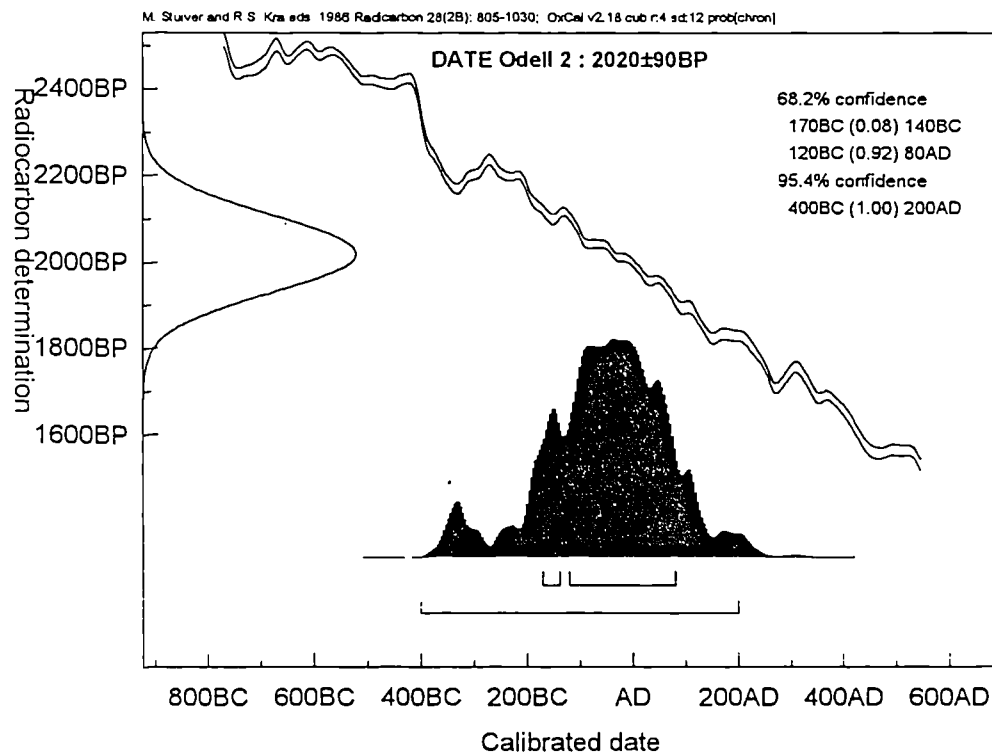
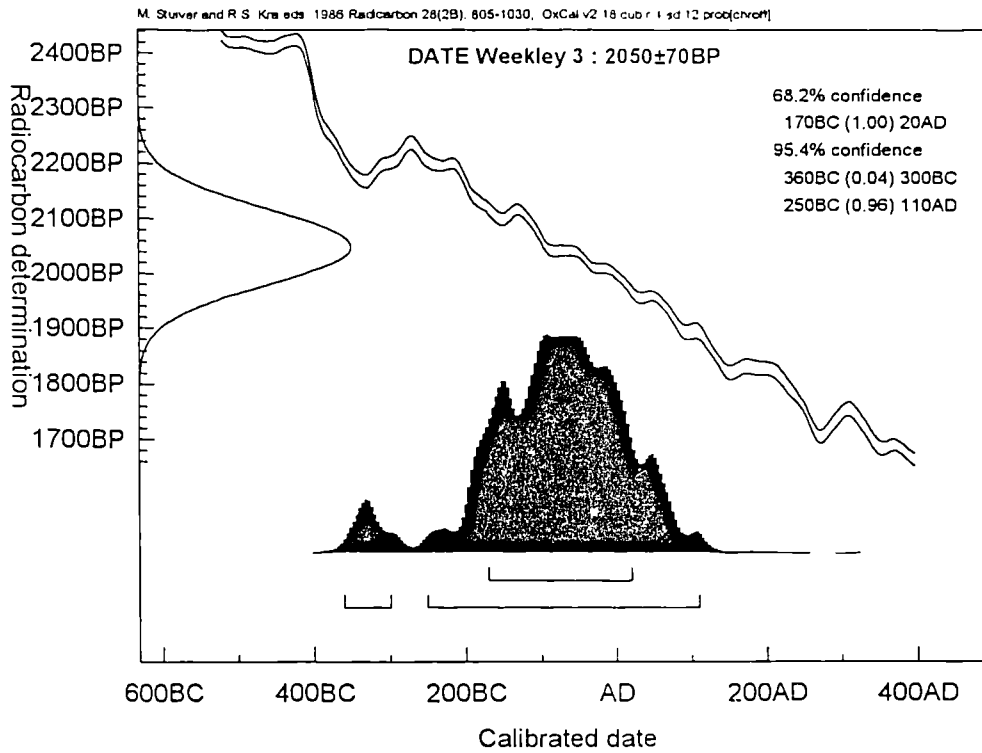

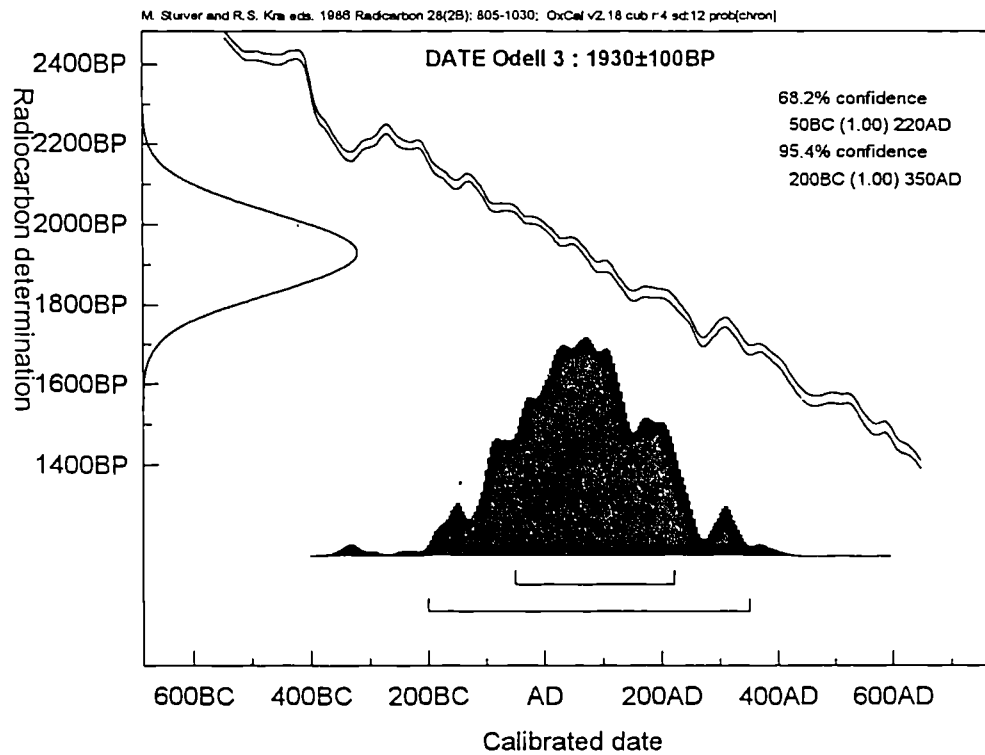
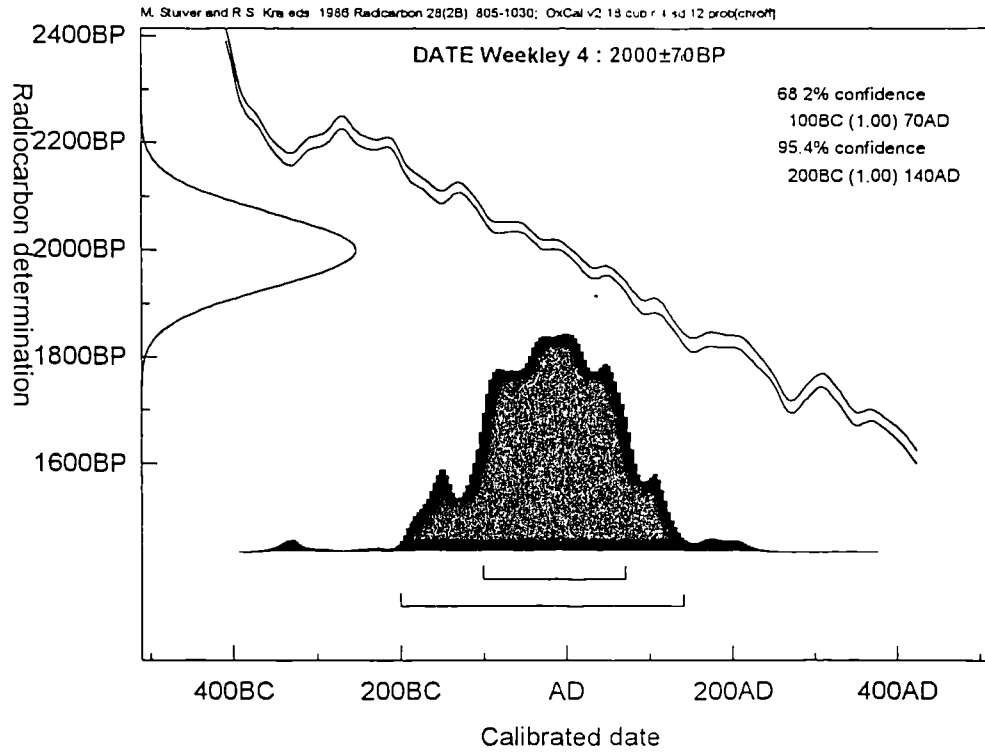

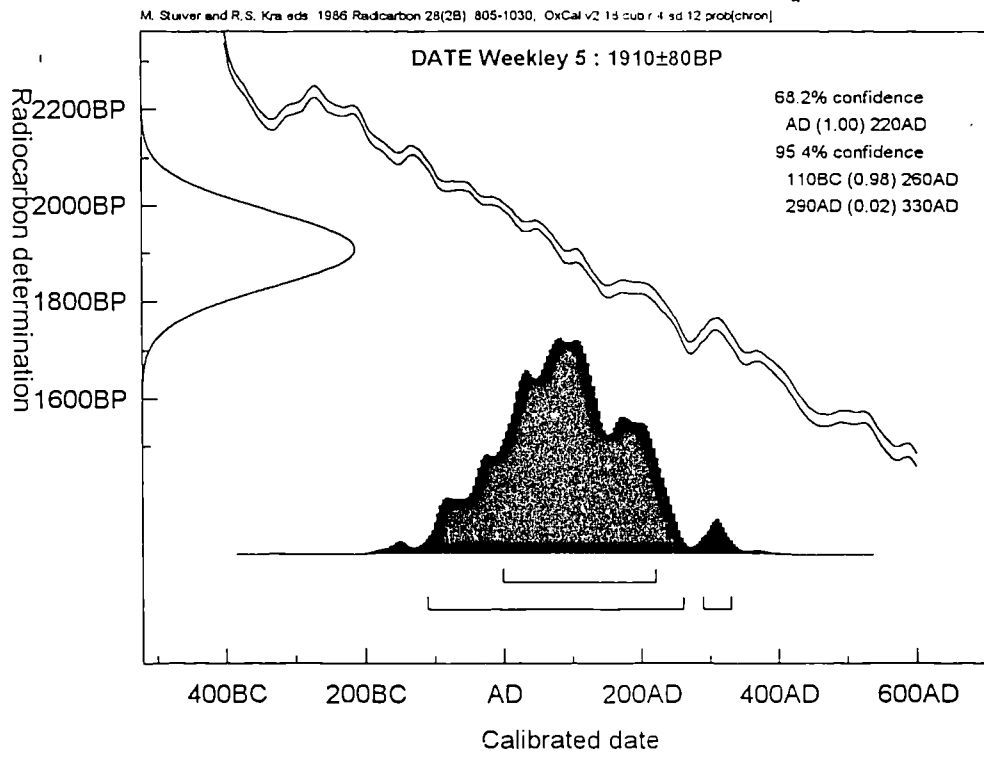

Acknowledgements

During the long and somewhat tortuous progress of this thesis I have received the help and support of a great many people. In the department I would especially like to thank Yvonne Beadnell for her advice with illustrations, Phil Clogg for patiently assisting me with the trend surface analysis, Pam Lowther for access to OxCal, and the secretaries for dealing with my more disorganised moments. I would also like to thank various members of the teaching staff for the patience and understanding they have shown over the delays and intermissions that occurred. I have also much appreciated the support of other post grads, especially Chris Loveluck, Steve Willis and Moraig Brown. During 1993 I contracted cancer and suspended my research until after treatment. Amongst those who helped so much at a difficult time I would especially like to say thanks to Jill Davy, whose ability to listen and support was second to none.

During my various visits to Northamptonshire Glenn Foard, Steve Parry, Ian Meadows and Jenny Kitchen have been particularly giving of their time and enthusiasm. I would also like to express thanks to Bob Bewley and the RCHM air photographic unit. Finally, I would especially like to thank my mum and dad for all their help and support (both personal and financial), Melanie Blackmore for putting up with the endless moans and delays, Adam Gwilt and Ed Eastaugh for beer, their friendship and doing the washing up, and Martin Millett for all things archaeological and departmental.